

- 14GA 2 x 2" STEEL TUBE CONSTRUCTION TYPICAL
- ASSEMBLY REQUIRED
- LOAD CAPACITY, EQUALLY DISTRIBUTED
 - COMBINED SYSTEM, NO CASTERS : 1200 LBS (880 LBS W/ CASTERS)
 - LOWER SHELF : 200 LBS
 - UPPER SHELVES : 150 LBS
- AVAILABLE SEPARATELY
 - UPRIGHT POST KIT WITH HORIZONTAL SUPPORTS (SHOWN)
 - 12" DEEP SHELF KIT (SHOWN WITH 2 SHELF KITS)
 - CHEM RESISTANT PHENOLIC WORK SURFACE (SHOWN)
 - SIDE APRON TO ACCOMMODATE 36" DEEP CUSTOM WORK SURFACE
 - SINGLE SUSPENDED DRAWER
 - SWIVEL CASTER KIT W/BRAKE
 - 24.75" DEEP LOWER SHELF W/BRACKETS (SHOWN)
 - SAFETY DIVIDER KITS; SIDE AND REAR, 1/4" ACRYLIC
- SEE PRICE LIST FOR FRAME AND ACCESSORY PART NUMBERS

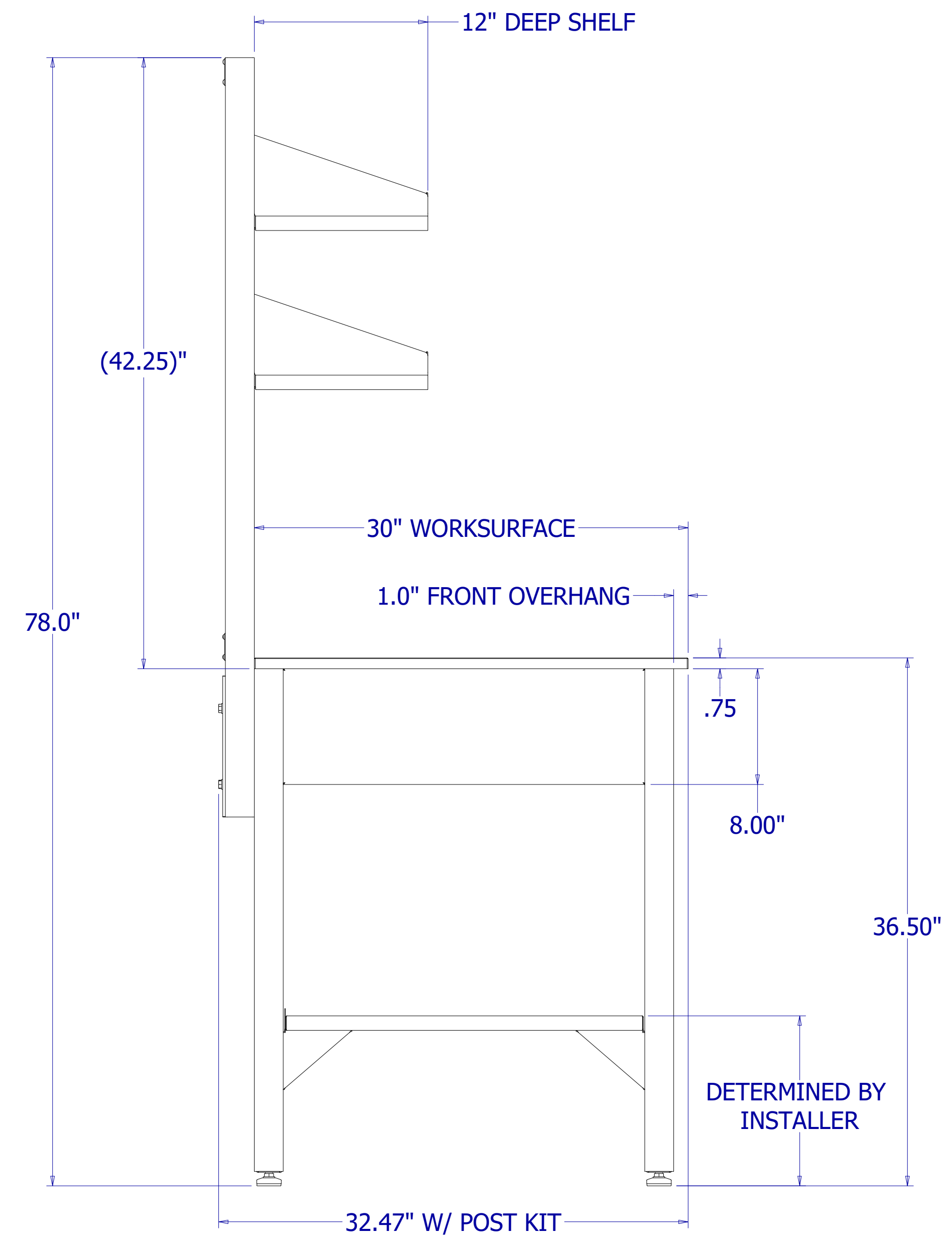

LL4830CRP: 48x30 PHENOLIC TOP
LL7230CRP: 72x30 PHENOLIC TOP

STANDARD SIZE MATRIX		
Table size	Frame width	Worksurface width
48 x 30	47-3/4"	48"
72 x 30	71-3/4"	72"

DRAWN	MWR	4/20/2020	LOOPED LOGIC		
CHECKED			747 Calle Plano, Camarillo CA 93012 866-340-2622		
QA			TITLE CUT SHEET, LOOPED LOGIC UTILITY TABLE, FIXED HT		
APPROVED			FINISH PETAL WHITE		
UNLESS OTHERWISE NOTED, GEN. TOLERANCE +/- .015"; ALL DIMENSIONS ARE IN INCHES	JOB #		SIZE	PART NO	REV
	QUOTE #		D		A
			SCALE	.15 MATL	SHEET 1 OF 1