

- 14GA 2 x 2" STEEL TUBE CONSTRUCTION TYPICAL
- ASSEMBLY REQUIRED
- STATIC LOAD CAPACITY, EQUALLY DISTRIBUTED
 - COMBINED SYSTEM, NO CASTERS : 1200 LBS (880 LBS W/ CASTERS)
 - LOWER SHELF : 200 LBS
 - UPPER SHELVES : 150 LBS
- AVAILABLE SEPARATELY
 - UPRIGHT POST KIT WITH HORIZONTAL SUPPORTS (SHOWN)
 - 12" DEEP SHELF KIT (SHOWN WITH 2 SHELF KITS)
 - CHEM RESISTANT PHENOLIC WORK SURFACE (SHOWN)
 - SIDE APRON TO ACCOMMODATE 36" DEEP CUSTOM WORK SURFACE
 - SINGLE SUSPENDED DRAWER
 - POWER STRIP KIT (REQ'S UPRIGHT POST KIT)
 - BIN BOX MOUNT BRACKET (REQ'S UPRIGHT POST KIT)
 - SWIVEL CASTER KIT W/BRAKE
 - 24.75" DEEP LOWER SHELF W/BRACKETS (SHOWN)
 - SAFETY DIVIDER KITS; SIDE AND REAR, 1/4" ACRYLIC
- SEE PRICE LIST FOR FRAME AND ACCESSORY PART NUMBERS



- UPRIGHT POST KITS
- K13409-36: 36W
 - K13409-48: 48W
 - K13409-60: 60W
 - K13409-72: 72W

- UPPER SHELF W/ BRKTS
- K13070-12: 36x12
 - K13032-12: 48x12
 - K13033-12: 60x12
 - K13034-12: 72x12

- PHENOLIC TOPS
- LL3630CRP: 36x30
 - LL4830CRP: 48x30
 - LL6030CRP: 60x30
 - LL7230CRP: 72x30

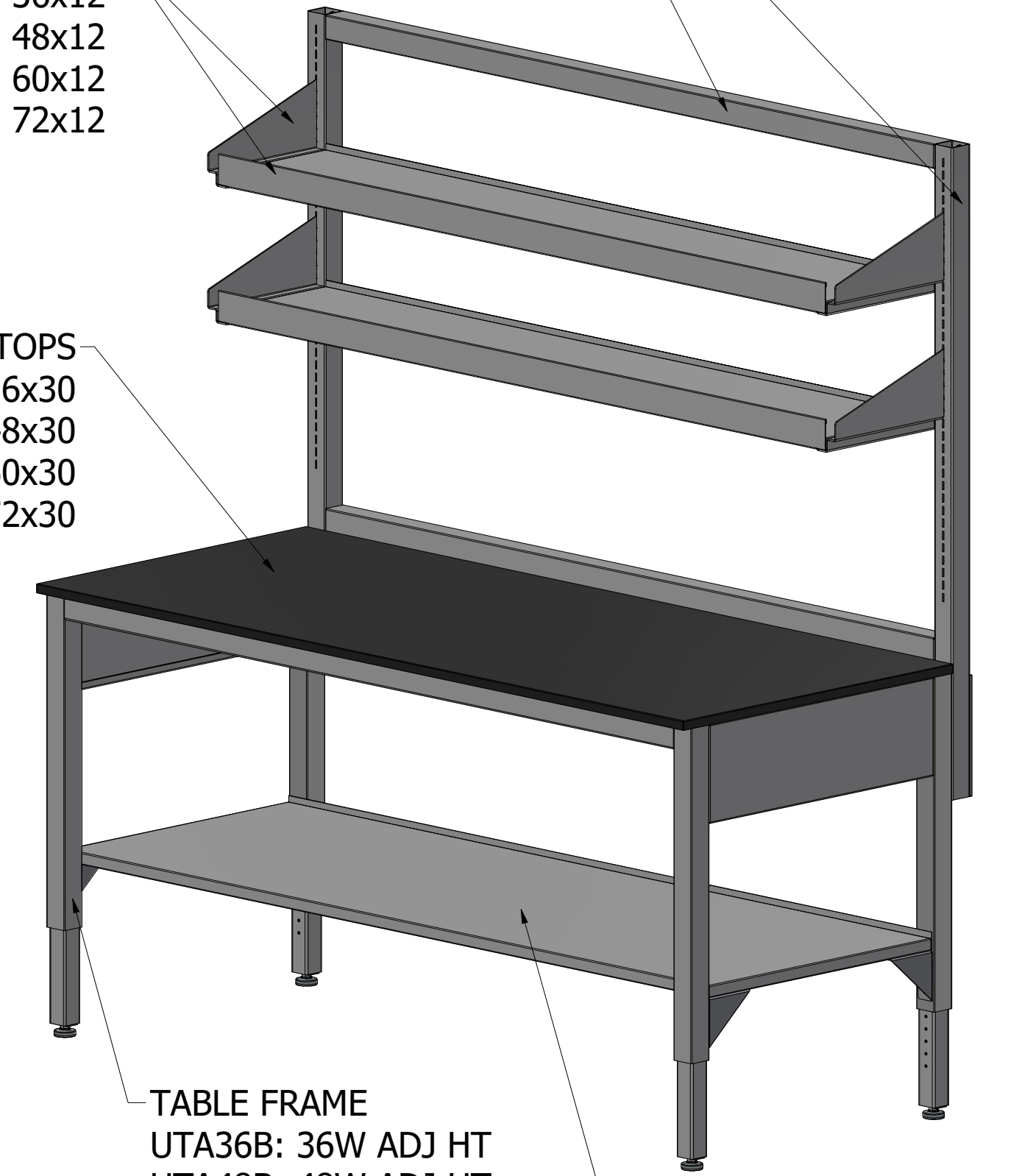

- TABLE FRAME
- UTA36B: 36W ADJ HT
 - UTA48B: 48W ADJ HT
 - UTA60B: 60W ADJ HT
 - UTA72B: 72W ADJ HT

- LOWER SHELF W/ BRKTS
- K7003-36: 36W
 - K7003-48: 48W
 - K7003-60: 60W
 - K7003-72: 72W

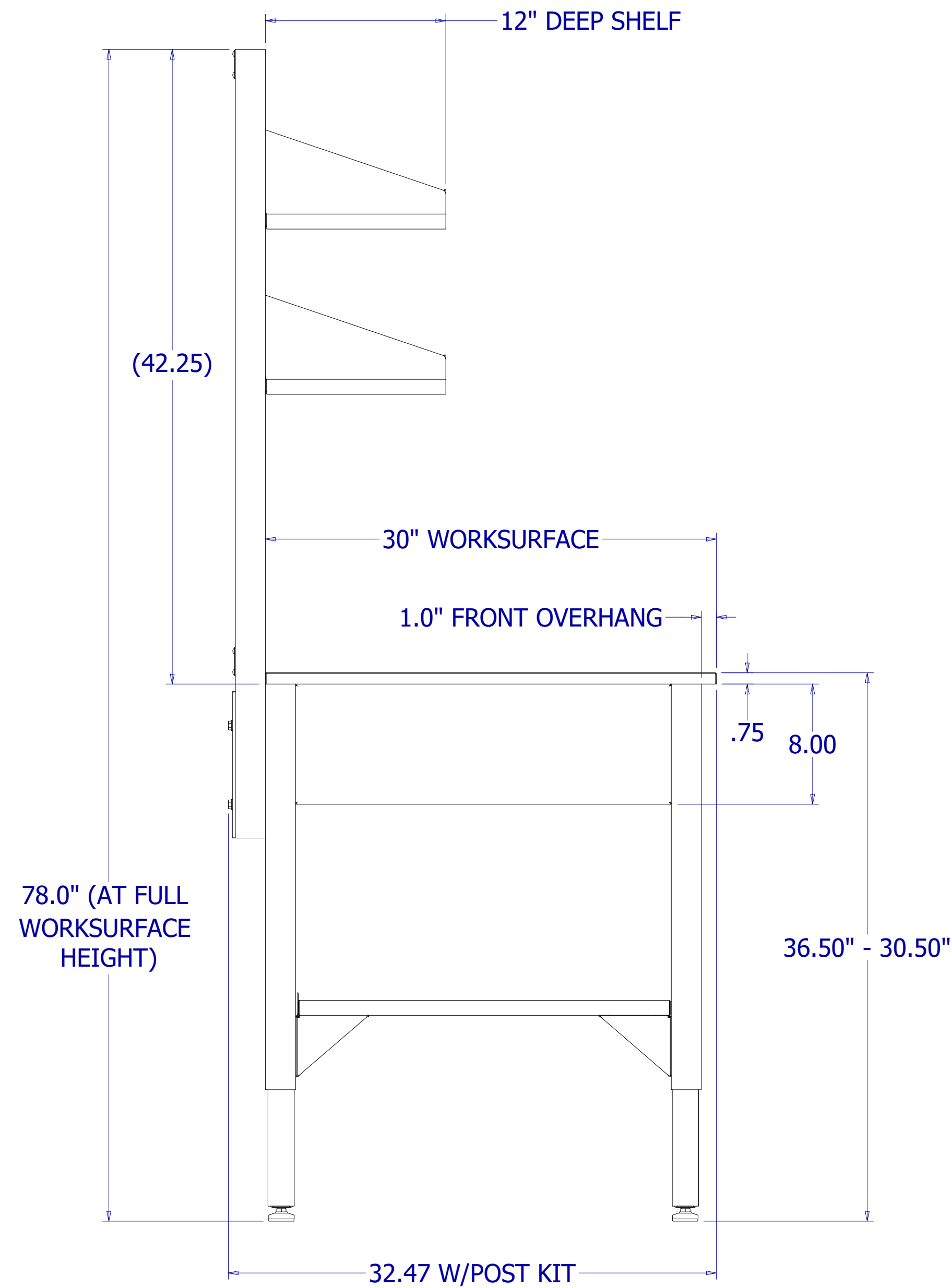

STANDARD SIZE MATRIX		
Table size	Frame width	Worksurface width
36 x 30	35-3/4"	36"
48 x 30	47-3/4"	48"
60 x 30	59-3/4"	60"
72 x 30	71-3/4"	72"

DRAWN	MWR	4/20/2020	LOOPED LOGIC		
CHECKED			747 Calle Plano, Camarillo CA 93012 866-340-2622		
QA			TITLE CUT SHEET, LOOPED LOGIC UTILITY TABLE, ADJ HT		
			FINISH PETAL WHITE		
APPROVED			SIZE	PART NO	REV
			D		A
UNLESS OTHERWISE NOTED, GEN. TOLERANCE +/- .015"; ALL DIMENSIONS ARE IN INCHES		JOB #	SCALE	MATL	SHEET 1 OF 1
		QUOTE #	.15		