

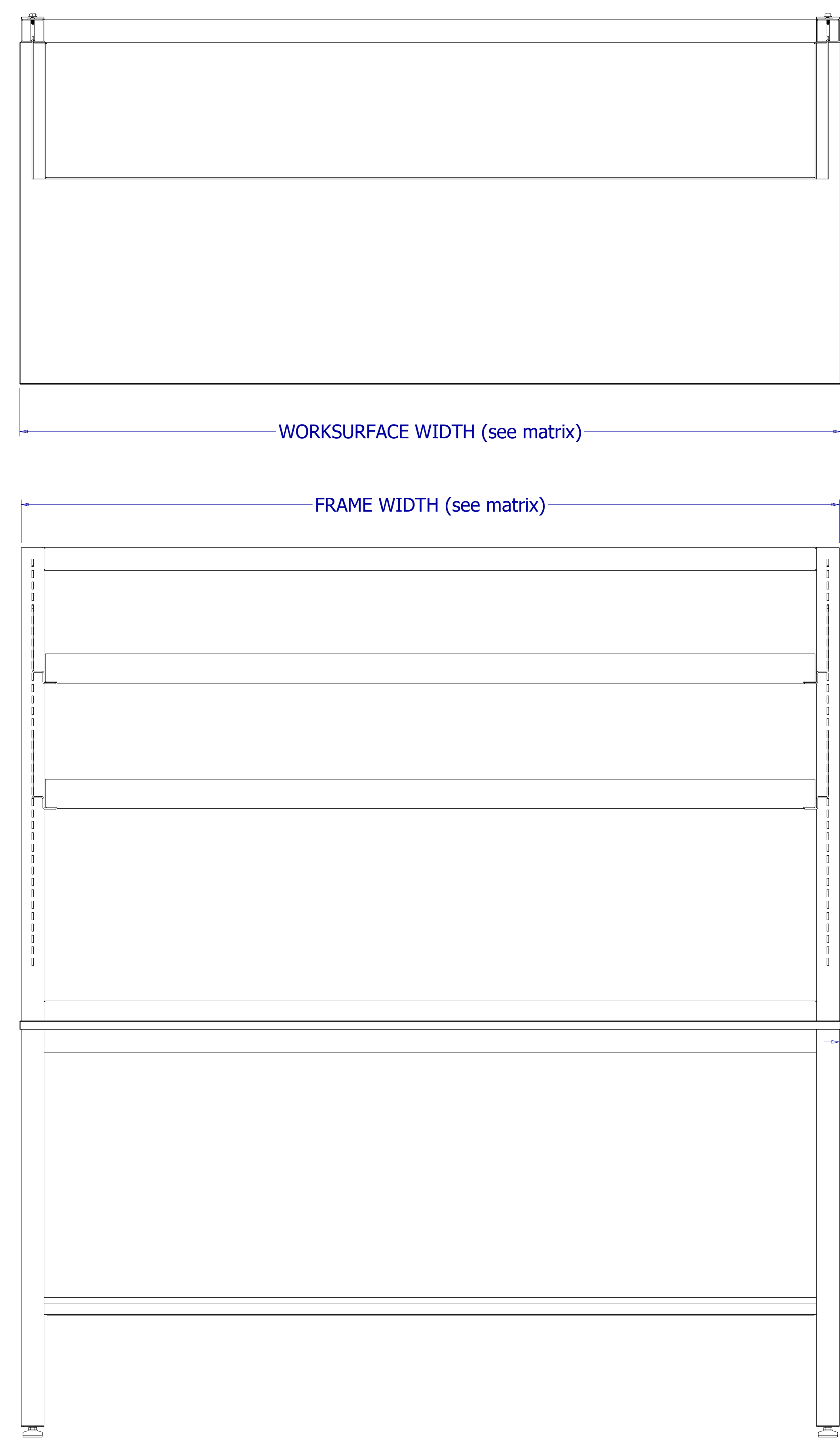

- 14GA 2 x 2" STEEL TUBE CONSTRUCTION TYPICAL
- ASSEMBLY REQUIRED
- STATIC LOAD CAPACITY, EQUALLY DISTRIBUTED
  - COMBINED SYSTEM, NO CASTERS : 1200 LBS (880 LBS W/ CASTERS)
  - LOWER SHELF : 200 LBS
  - UPPER SHELVES : 150 LBS
- AVAILABLE SEPARATELY
  - UPRIGHT POST KIT WITH HORIZONTAL SUPPORTS (SHOWN)
  - 12" DEEP SHELF KIT (SHOWN WITH 2 SHELF KITS)
  - CHEM RESISTANT PHENOLIC WORK SURFACE (SHOWN)
  - SIDE APRON TO ACCOMMODATE 36" DEEP CUSTOM WORK SURFACE
  - SINGLE SUSPENDED DRAWER
  - POWER STRIP KIT (REQ'S UPRIGHT POST KIT)
  - BIN BOX MOUNT BRACKET (REQ'S UPRIGHT POST KIT)
  - SWIVEL CASTER KIT W/BRAKE
  - 24.75" DEEP LOWER SHELF W/BRACKETS (SHOWN)
  - SAFETY DIVIDER KITS; SIDE AND REAR, 1/4" ACRYLIC
- SEE PRICE LIST FOR FRAME AND ACCESSORY PART NUMBERS

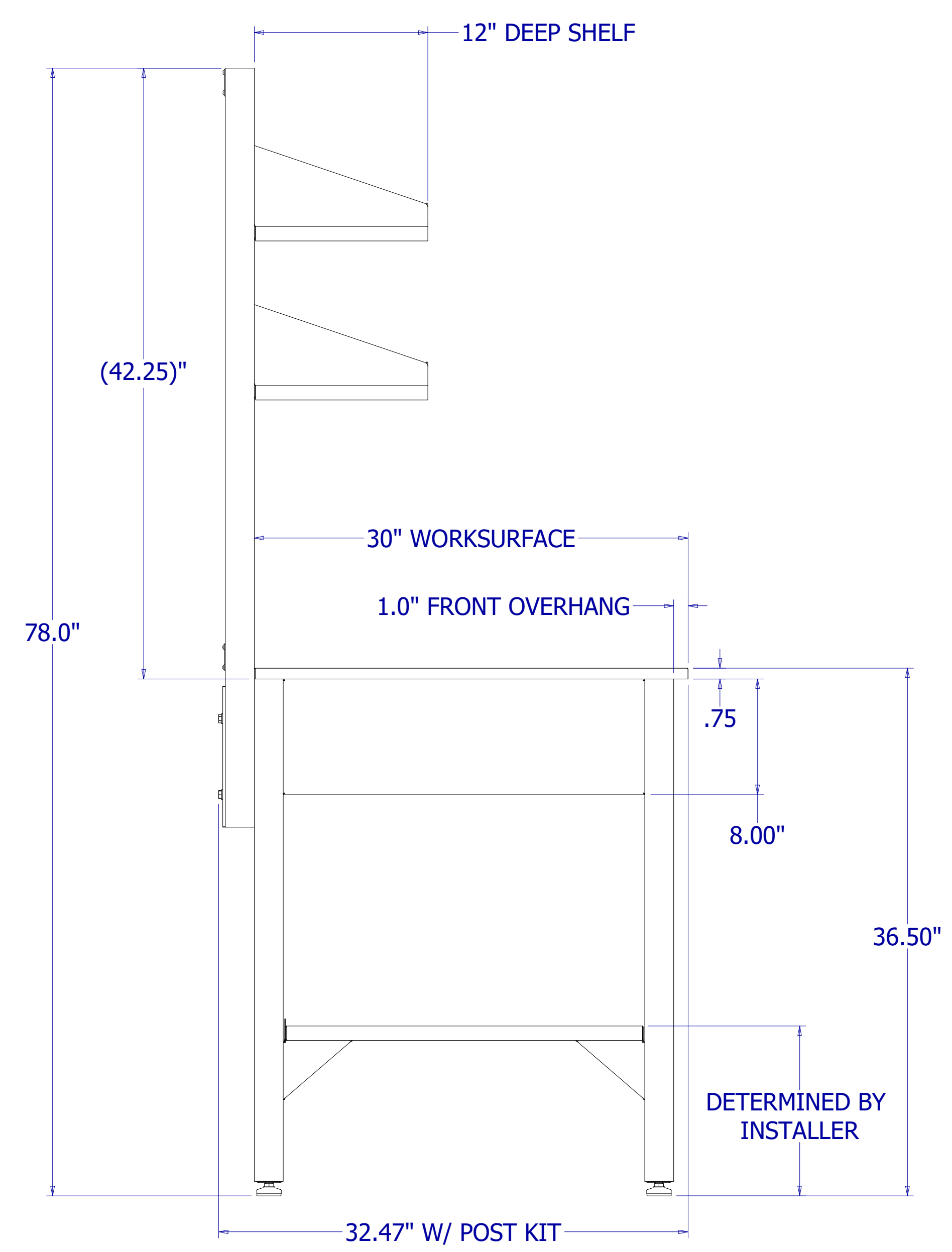

- UPRIGHT POST KITS  
 K13409-36: 36W  
 K13409-48: 48W  
 K13409-60: 60W  
 K13409-72: 72W
- UPPER SHELF W/ BRKTS  
 K13070-12: 36x12  
 K13032-12: 48x12  
 K13033-12: 60x12  
 K13034-12: 72x12
- PHENOLIC TOPS  
 LL3630CRP: 36x30  
 LL4830CRP: 48x30  
 LL6030CRP: 60x30  
 LL7230CRP: 72x30
- TABLE FRAME  
 UTFH36B: 36W FIXED HT  
 UTFH48B: 48W FIXED HT  
 UTFH60B: 60W FIXED HT  
 UTFH72B: 72W FIXED HT
- LOWER SHELF W/ BRKTS  
 K7003-36: 36W  
 K7003-48: 48W  
 K7003-60: 60W  
 K7003-72: 72W



STANDARD SIZE MATRIX		
Table size	Frame width	Worksurface width
36 x 30	35-3/4"	36"
48 x 30	47-3/4"	48"
60 x 30	59-3/4"	60"
72 x 30	71-3/4"	72"

DRAWN	MWR	4/20/2020	LOOPED LOGIC		
CHECKED			747 Calle Plano, Camarillo CA 93012   866-340-2622		
QA			TITLE CUT SHEET, LOOPED LOGIC UTILITY TABLE, FIXED HT		
APPROVED			FINISH PETAL WHITE		
UNLESS OTHERWISE NOTED, GEN. TOLERANCE +/- .015"; ALL DIMENSIONS ARE IN INCHES	JOB #		SIZE	PART NO	REV
	QUOTE #		D		A
			SCALE	.15 MATL	SHEET 1 OF 1