

## Heavy Duty Fixed Height Tables

- Heavy Duty welded construction, complete with leveling glides and vinyl shoes.
- Tables can be used with a bottom shelf, suspended or mobile cabinet.
- Caster kits are available for added mobility.
- Counter top, brackets, shelves, and cabinets must be ordered separately.
- Shipped fully assembled, except for shelves, countertop, or accessories.

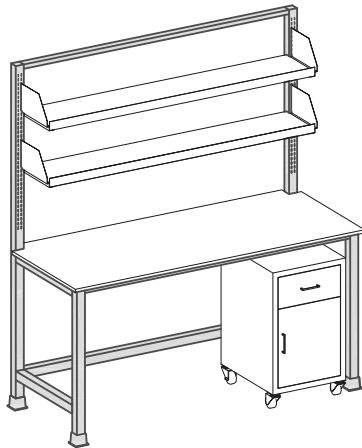

### Heavy Duty Welded Tables 29-3/4" High with 78" high Shelf Upright Posts

Total Height 78" to top of upright posts.  
Rear upright posts are 2" wide by 2" deep.

Model	Frame Width	Frame Depth	Top Size
HDWU34A29	34"	23"	36" x 25"
HDWU46A29	46"	23"	48" x 25"
HDWU58A29	58"	23"	60" x 25"
HDWU70A29	70"	23"	72" x 25"
HDWU34B29	34"	28"	36" x 30"
HDWU46B29	46"	28"	48" x 30"
HDWU58B29	58"	28"	60" x 30"
HDWU70B29	70"	28"	72" x 30"

### Heavy Duty Welded Tables 35-3/4" High with 78" high Shelf Upright Posts

Total Height 78" to top of upright posts.  
Rear upright posts are 2" wide by 2" deep.

Model	Frame Width	Frame Depth	Top Size
HDWU34A35	34"	23"	36" x 25"
HDWU46A35	46"	23"	48" x 25"
HDWU58A35	58"	23"	60" x 25"
HDWU70A35	70"	23"	72" x 25"
HDWU34B35	34"	28"	36" x 30"
HDWU46B35	46"	28"	48" x 30"
HDWU58B35	58"	28"	60" x 30"
HDWU70B35	70"	28"	72" x 30"

### Heavy Duty Welded Tables 29-3/4" High

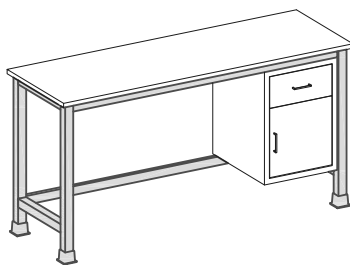

Model	Frame Width	Frame Depth	Top Size
HDW34A29	34"	23"	36" x 25"
HDW46A29	46"	23"	48" x 25"
HDW58A29	58"	23"	60" x 25"
HDW70A29	70"	23"	72" x 25"
HDW34B29	34"	28"	36" x 30"
HDW46B29	46"	28"	48" x 30"
HDW58B29	58"	28"	60" x 30"
HDW70B29	70"	28"	72" x 30"

### Heavy Duty Welded Tables 35-3/4" High

Model	Frame Width	Frame Depth	Top Size
HDW34A35	34"	23"	36" x 25"
HDW46A35	46"	23"	48" x 25"
HDW58A35	58"	23"	60" x 25"
HDW70A35	70"	23"	72" x 25"
HDW34B35	34"	28"	36" x 30"
HDW46B35	46"	28"	48" x 30"
HDW58B35	58"	28"	60" x 30"
HDW70B35	70"	28"	72" x 30"

### Bottom Table Shelf

- A painted steel shelf attached to the bottom leg assembly.
- Included is a bottom CB style cross brace for added support of the bottom shelf.

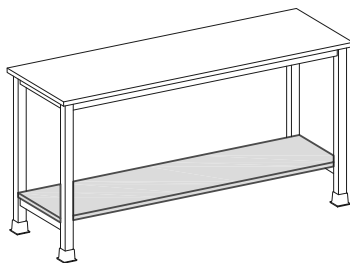

Model	Table Frame Width	Shelf Depth	Top Size
TS34A	34"	18"	36" x 24"D
TS46A	46"	18"	48" x 24"D
TS58A	58"	18"	60" x 24"D
TS70A	70"	18"	72" x 24"D
TS34B	34"	24"	36" x 30"D
TS46B	46"	24"	48" x 30"D
TS58B	58"	24"	60" x 30"D
TS70B	70"	24"	72" x 30"D

# Tables

# Utility Tables

## Standard Duty Adjustable & Fixed Height Table Frames

- Counter height adjustment is from 28" to 42".
- Tables can be used with a bottom shelf, suspended or mobile cabinet.
- Counter top, brackets, shelves, and cabinets must be ordered separately.
- Assembly required.

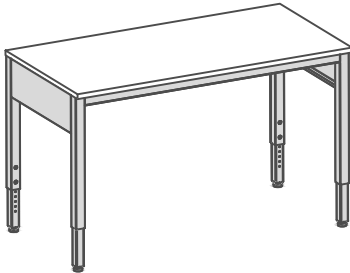

## Adjustable Height Utility Tables

Counter top height adjustment is from 30-3/4" - 36-3/4"

Model	Frame Width	Frame Depth	Top Size
UTA36B	35-3/4"	29"	36" x 30"
UTA48B	47-3/4"	29"	48" x 30"
UTA60B	59-3/4"	29"	60" x 30"
UTA72B	71-3/4"	29"	72" x 30"
UTA36C	35-3/4"	35"	36" x 36"
UTA48C	47-3/4"	35"	48" x 36"
UTA60C	59-3/4"	35"	60" x 36"
UTA72C	71-3/4"	35"	72" x 36"

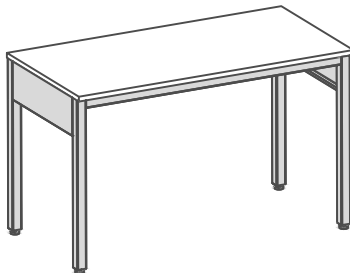

## Fixed Height Utility Tables 35-3/4 High

Model	Frame Width	Frame Depth	Top Size
UTFH36B	35-3/4"	29"	36" x 30"
UTFH48B	47-3/4"	29"	48" x 30"
UTFH60B	59-3/4"	29"	60" x 30"
UTFH72B	71-3/4"	23"	72" x 30"
UTFH36C	35-3/4"	35"	36" x 36"
UTFH48C	47-3/4"	35"	48" x 36"
UTFH60C	59-3/4"	35"	60" x 36"
UTFH72C	71-3/4"	35"	72" x 36"

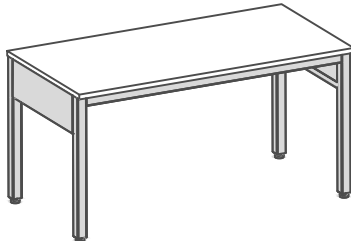

## Fixed Height Utility Tables 29-3/4 High

Model	Frame Width	Frame Depth	Top Size
UTFL36B	35-3/4"	29"	36" x 30"
UTFL48B	47-3/4"	29"	48" x 30"
UTFL60B	59-3/4"	29"	60" x 30"
UTFL72B	71-3/4"	29"	72" x 30"
UTFL36C	35-3/4"	35"	36" x 36"
UTFL48C	47-3/4"	35"	48" x 36"
UTFL60C	59-3/4"	35"	60" x 36"
UTFL72C	71-3/4"	35"	72" x 36"

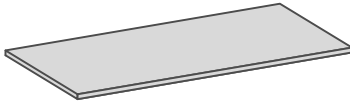

### Work Surface

CHEMICAL RESISTANT BLACK PHENOLIC RESIN (36" DEEP SIZES CAN BE CUSTOM ORDERED)

Model	Length	Depth	Thickness
LL3630CRP	36"	30"	3/4"
LL4830CRP	48"	30"	3/4"
LL6030CRP	60"	30"	3/4"
LL7230CRP	72"	30"	3/4"

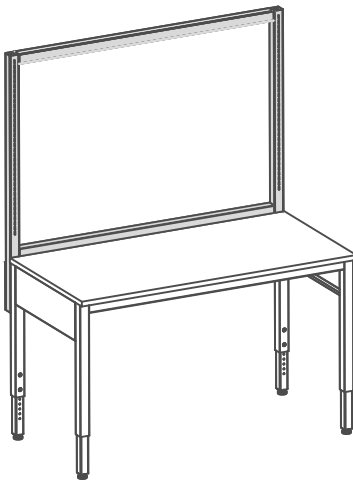

### Upright Post Kits

Includes 2" X 2" vertical posts, horizontal cross members, and hardware. Table, shelves, and shelf brackets not included

Model	Frame Width	Frame height
K13409-36	35-3/4"	52-1/2"
K13409-48	47-3/4"	52-1/2"
K13409-60	59-3/4"	52-1/2"
K13409-72	71-3/4"	52-1/2"

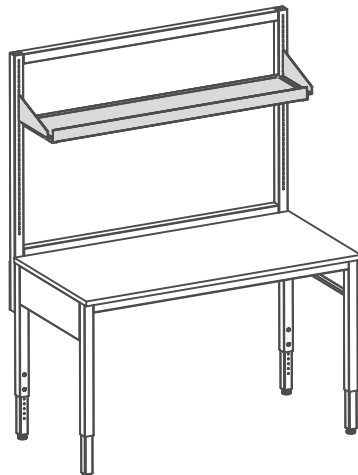

### Upper Shelf Kits

Includes 12" deep painted metal shelf, and brackets. Requires upright post kit, and table sold separately

Model	Width	Depth
K13070-12	31-1/2"	12"
K13032-12	43-1/2"	12"
K13033-12	55-1/2"	12"
K13034-12	67-1/2"	12"

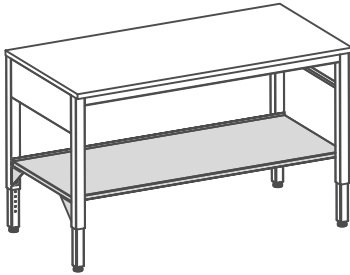

### Lower Shelving Kits

Under counter use includes shelf, & mounting brackets. Table frame, & work surface sold separately.

Model	Length	Depth
K7003-36	35-1/2"	24-3/4"
K7003-48	47-1/2"	24-3/4"
K7003-60	59-3/4"	24-3/4"
K7003-72	71-3/4"	24-3/4"

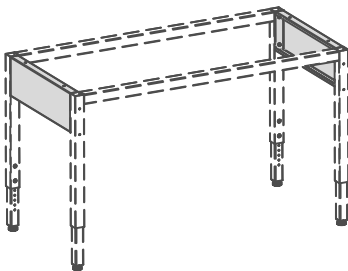

### Frame Depth Extension Apron

Accommodates 36" deep work custom work surface. Kit includes 2 aprons, Table frame & work surface sold separately.

Model	Apron Width
K13408-36	31"

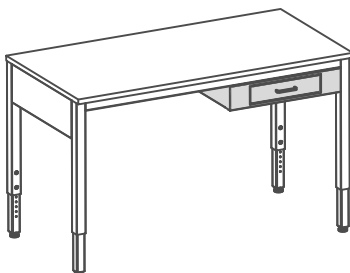

### Single Drawer

Includes Includes single 24" x 28" drawer housing. Table frame and work surface sold separately

Model	Width	Depth
LLDH-1-24B	24-1/8"	28"

# Utility Tables

# Accessories

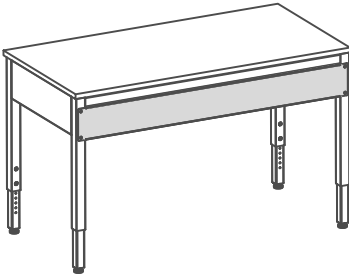

## Rear Apron

Suggested for applications with dynamic equipment

Model	Length	Height
C13406-36	36"	6-1/2"
C13406-48	48"	6-1/2"
C13406-60	60"	6-1/2"
C13406-72	72"	6-1/2"

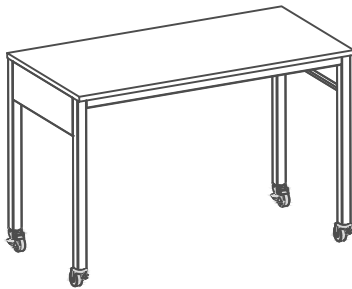

## Caster Kit

1/2" - 13 Stem swivel casters with brake

Model	Width	Depth
H261	CASTER, 3.5"Ø LT MED GRAY 4.75" OHA	
H262	CASTER, 4"Ø LT-MED GRAY, 5.25" OHA	

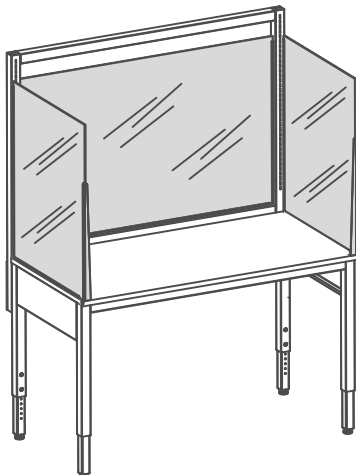

## Safety Divider Kits

Made From 1/4" clear acrylic, includes mounting brackets. Side panels & back panels must be ordered separately (requires some drilling for installation)

Model	Length	Height
K13314-30	30"	36" (SIDE PANELS)
K13314-36	36"	36" (SIDE PANELS)
K13313-36	36"	36" (BACK PANEL)
K13313-48	48"	36" (BACK PANEL)
K13313-60	60"	36" (BACK PANEL)
K13313-72	72"	36" (BACK PANEL)

### C-Frame Heavy Duty Fixed Height Tables

- Fixed height tables with leveling glides.
- Tables can be used with a bottom shelf, suspended or mobile cabinet.
- Caster kits are available for added mobility.
- Countertop, brackets, shelves, and cabinets must be ordered separately.
- Assembly required.

### C-Frame Tables 29-3/4" High with 78" High Shelf Upright Posts

Total Height 78" to top of upright posts.  
Rear upright posts are 2" wide by 2" deep.

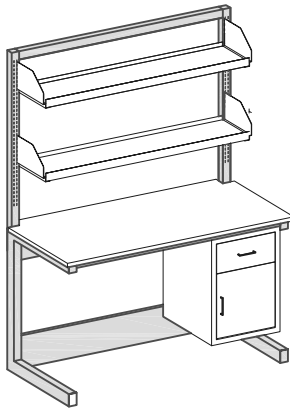

Model	Frame Width	Frame Depth	Top Size
CFTU34A29	34"	23"	36" x 25"
CFTU46A29	46"	23"	48" x 25"
CFTU58A29	58"	23"	60" x 25"
CFTU70A29	70"	23"	72" x 25"
CFTU34B29	34"	28"	36" x 30"
CFTU46B29	46"	28"	48" x 30"
CFTU58B29	58"	28"	60" x 30"
CFTU70B29	70"	28"	72" x 30"

### C-Frame Tables 35-3/4" High with 78" High Shelf Upright Posts

Total Height 78" to top of upright posts.  
Rear upright posts are 2" wide by 2" deep.

Model	Table Width	Table Depth	Top Size
CFTU34A35	34"	23"	36" x 25"
CFTU46A35	46"	23"	48" x 25"
CFTU58A35	58"	23"	60" x 25"
CFTU70A35	70"	23"	72" x 25"
CFTU34B35	34"	28"	36" x 30"
CFTU46B35	46"	28"	48" x 30"
CFTU58B35	58"	28"	60" x 30"
CFTU70B35	70"	28"	72" x 30"

### C-Frame Tables 29-3/4" High

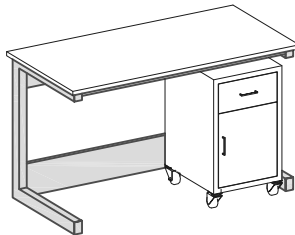

Model	Frame Width	Frame Depth	Top Size
CFT34A29	34"	23"	36" x 25"
CFT46A29	46"	23"	48" x 25"
CFT58A29	58"	23"	60" x 25"
CFT70A29	70"	23"	72" x 25"
CFT34B29	34"	28"	36" x 30"
CFT46B29	46"	28"	48" x 30"
CFT58B29	58"	28"	60" x 30"
CFT70B29	70"	28"	72" x 30"

### C-Frame Tables 35-3/4" High

Model	Frame Width	Frame Depth	Top Size
CFT34A35	34"	23"	36" x 25"
CFT46A35	46"	23"	48" x 25"
CFT58A35	58"	23"	60" x 25"
CFT70A35	70"	23"	72" x 25"
CFT34B35	34"	28"	36" x 30"
CFT46B35	46"	28"	48" x 30"
CFT58B35	58"	28"	60" x 30"
CFT70B35	70"	28"	72" x 30"

### Bottom Table Shelf

- A painted steel shelf attached to the bottom leg assembly.
- Included is a bottom CB style cross brace for added support of the bottom shelf.

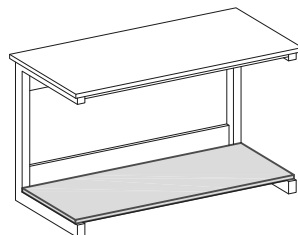

Model	Table Frame Width	Shelf Depth
TS34A	34"	18"
TS46A	46"	18"
TS58A	58"	18"
TS70A	70"	18"
TS34B	34"	24"
TS46B	46"	24"
TS58B	58"	24"
TS70B	70"	24"

### Starter Tables

C-Frame tables can be used as mobile individual tables or as starter tables for our Add-a-Bench table system.

### C-Frame Heavy Duty Fixed Height Tables

- Fixed height tables with leveling glides.
- Tables can be used with a bottom shelf, suspended or mobile cabinet.
- Countertop, brackets, shelves, and cabinets must be ordered separately.
- Assembly required.

### C-Frame Double Island Tables 29-3/4" High with 78" High Shelf Upright Posts

Total Height 78" to the top of the upright posts. Center upright posts are 2" wide by 3" deep.

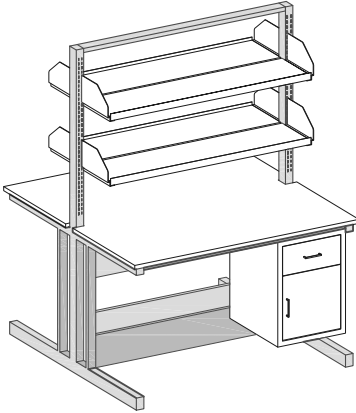

Model	Frame Width	Frame Depth	Top Size
CFTU34D29	34"	58"	36" x 60"
CFTU46D29	46"	58"	48" x 60"
CFTU58D29	58"	58"	60" x 60"
CFTU70D29	70"	58"	72" x 60"

### C-Frame Double Island Tables 35-3/4" High with 78" High Shelf Upright Posts

Total Height 78" to the top of the upright posts. Center upright posts are 2" wide by 3" deep.

Model	Frame Width	Frame Depth	Top Size
CFTU34D35	34"	58"	36" x 60"
CFTU46D35	46"	58"	48" x 60"
CFTU58D35	58"	58"	60" x 60"
CFTU70D35	70"	58"	72" x 60"

### C-Frame Double Island Tables 29-3/4" High

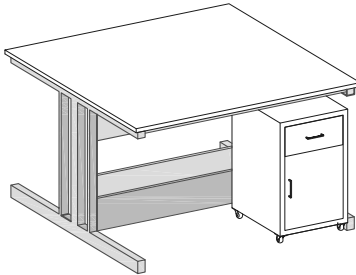

Model	Frame Width	Frame Depth	Top Size
CFT34D29	34"	58"	36" x 60"
CFT46D29	46"	58"	48" x 60"
CFT58D29	58"	58"	60" x 60"
CFT70D29	70"	58"	72" x 60"

### C-Frame Double Island Tables 35-3/4" High

Model	Frame Width	Frame Depth	Top Size
CFT34D35	34"	58"	36" x 60"
CFT46D35	46"	58"	48" x 60"
CFT58D35	58"	58"	60" x 60"
CFT70D35	70"	58"	72" x 60"

### Bottom Table Shelf

- A painted steel shelf attached to the bottom leg assembly. Order one shelf kit for each side of the table.
- Included is a bottom CB style cross brace for added support of the bottom shelf.

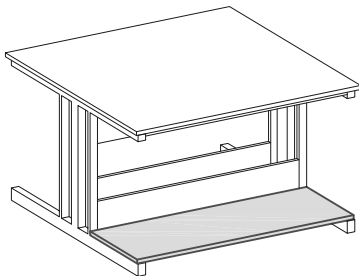

Model	Table Frame Width	Shelf Depth
TS34A	34"	18"
TS46A	46"	18"
TS58A	58"	18"
TS70A	70"	18"
TS34B	34"	24"
TS46B	46"	24"
TS58B	58"	24"
TS70B	70"	24"

### Starter Tables

C-Frame tables can be used as mobile individual tables or as starter tables for our Add-a-Bench table system.

### Double Island - End View

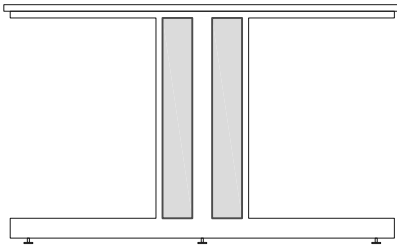

### Double Island - Front View

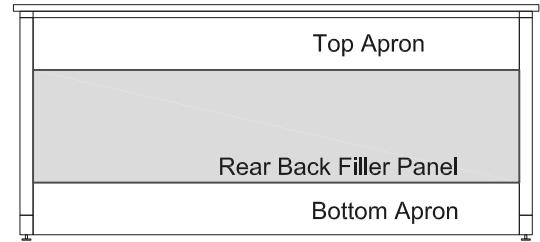

### End Filler Panels

- Used to completely close off the space between the leg supports of C-Frame double island tables.

Model	Table Height
EFP25	29-3/4"
EFP31	35-3/4"

### Rear Center Back Filler Panels

- Used to completely close off the back of each side of C-Frame double island tables.
- The model number includes a set of two, one for each side.

Model	Table Height	Table Width
RBP-L-3	29-3/4"	34"
RBP-L-4	29-3/4"	46"
RBP-L-5	29-3/4"	58"
RBP-L-6	29-3/4"	70"
RBP-H-3	35-3/4"	34"
RBP-H-4	35-3/4"	46"
RBP-H-5	35-3/4"	58"
RBP-H-6	35-3/4"	70"





### Features and Benefits

- This Add-a-Bench system is a very economical design approach to create continuous workstations side by side, using common end leg structures in lieu of individual tables.
- This system can be used with single sided C-Frame tables or double sided island tables.
- Like the individual C-Frame tables, bottom shelves, mobile or suspended cabinets can be used with the system.
- Order brackets, shelving, counter tops, and accessories separately.

### How to design and order HLF Add-a-Bench systems.

- Start with the C-Frame tables on the previous pages.
- Add additional adder benches from the lists below.
- Adder benches can be different widths but need to be the same style and counter height.
- Add table accessories.

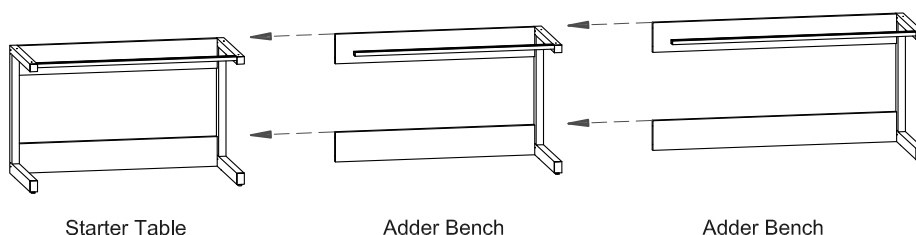

### Single Sided Adder Benches

29-3/4" high tables.

Model	Table Frame		Top Size
	Width	Depth	
CFT34A29ADD	34"	23"	36" x 25"
CFT46A29ADD	46"	23"	48" x 25"
CFT58A29ADD	58"	23"	60" x 25"
CFT70A29ADD	70"	23"	72" x 25"
CFT34B29ADD	34"	28"	36" x 30"
CFT46B29ADD	46"	28"	48" x 30"
CFT58B29ADD	58"	28"	60" x 30"
CFT70B29ADD	70"	28"	72" x 30"



Adder Bench

### Single Sided Adder Benches

35-3/4" high tables.

Model	Table Frame		Top Size
	Width	Depth	
CFT34A35ADD	34"	23"	36" x 25"
CFT46A35ADD	46"	23"	48" x 25"
CFT58A35ADD	58"	23"	60" x 25"
CFT70A35ADD	70"	23"	72" x 25"
CFT34B35ADD	34"	28"	36" x 30"
CFT46B35ADD	46"	28"	48" x 30"
CFT58B35ADD	58"	28"	60" x 30"
CFT70B35ADD	70"	28"	72" x 30"

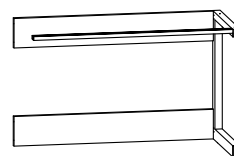

Adder Bench

### Features and Benefits

- This Add-a-Bench system is a very economical design approach to create continuous workstations side by side, using common end leg structures in lieu of individual tables.
- This system can be used with single sided C-Frame tables or double sided island tables.
- Like the individual C-Frame tables, bottom shelves, mobile or suspended cabinets can be used with the system.
- Order brackets, shelving, counter tops, and accessories separately.

### How to design and order HLF Add-a-Bench systems.

- Start with the C-Frame tables on the previous pages.
- Add additional adder benches from the lists below.
- Adder benches can be different widths but need to be the same style and counter height.
- Add table accessories.

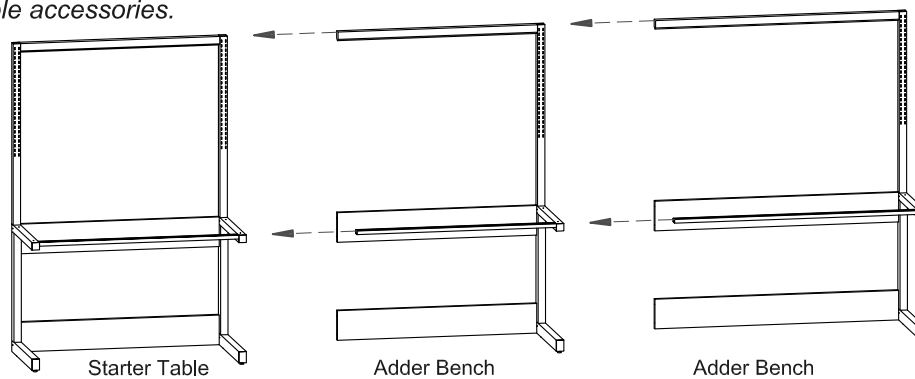

### Single Sided Adder Benches

29-3/4" high tables with Shelf Upright Posts.

Model	Table Frame		Top Size
	Width	Depth	
CFTU34A29ADD	34"	23"	36" x 25"
CFTU46A29ADD	46"	23"	48" x 25"
CFTU58A29ADD	58"	23"	60" x 25"
CFTU70A29ADD	70"	23"	72" x 25"
CFTU34B29ADD	34"	28"	36" x 30"
CFTU46B29ADD	46"	28"	48" x 30"
CFTU58B29ADD	58"	28"	60" x 30"
CFTU70B29ADD	70"	28"	72" x 30"

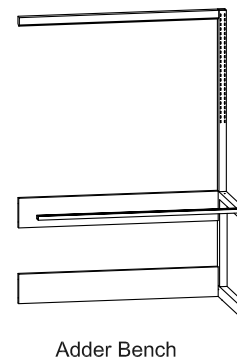

### Single Sided Adder Benches

35-3/4" high tables with Shelf Upright Posts.

Model	Table Frame		Top Size
	Width	Depth	
CFTU34A35ADD	34"	23"	36" x 25"
CFTU46A35ADD	46"	23"	48" x 25"
CFTU58A35ADD	58"	23"	60" x 25"
CFTU70A35ADD	70"	23"	72" x 25"
CFTU34B35ADD	34"	28"	36" x 30"
CFTU46B35ADD	46"	28"	48" x 30"
CFTU58B35ADD	58"	28"	60" x 30"
CFTU70B35ADD	70"	28"	72" x 30"

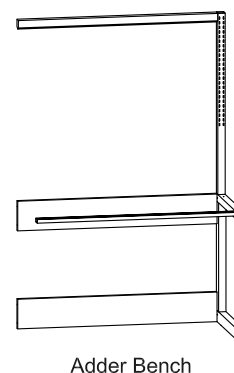

### Features and Benefits

- This Add-a-Bench system is a very economical design approach to create continuous workstations side by side, using common end leg structures in lieu of individual tables.
- This system can be used with single sided C-Frame tables or double sided island tables.
- Like the individual C-Frame tables, bottom shelves, mobile or suspended cabinets can be used with the system.
- Order brackets, shelving, counter tops, and accessories separately.

### How to design and order HLF Add-a-Bench systems.

- Start with the C-Frame tables on the previous pages.
- Add additional adder benches from the lists below.
- Adder benches can be different widths but need to be the same style and counter height.
- Add table accessories.

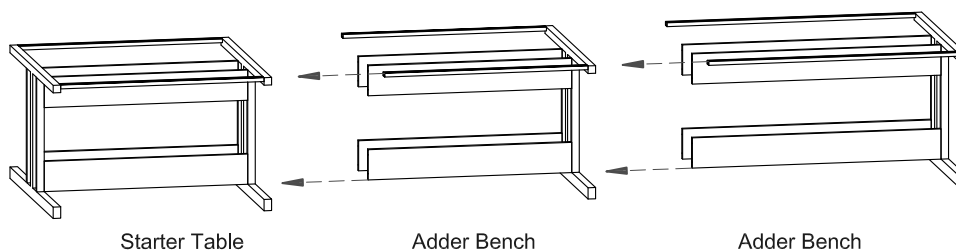

### Double Sided Island Adder Benches

29-3/4" high tables.

Model	Table Frame		Top Size
	Width	Depth	
CFT34D29ADD	34"	58"	36" x 60"
CFT46D29ADD	46"	58"	48" x 60"
CFT58D29ADD	58"	58"	60" x 60"
CFT70D29ADD	70"	58"	72" x 60"

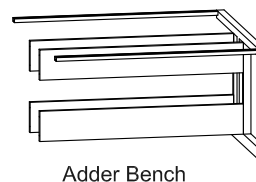

### Double Sided Island Adder Benches

35-3/4" high tables.

Model	Table Frame		Top Size
	Width	Depth	
CFT34D35ADD	34"	58"	36" x 60"
CFT46D35ADD	46"	58"	48" x 60"
CFT58D35ADD	58"	58"	60" x 60"
CFT70D35ADD	70"	58"	72" x 60"

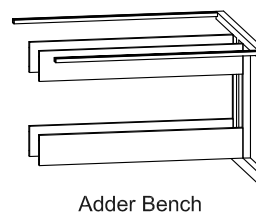

### Features and Benefits

- This Add-a-Bench system is a very economical design approach to create continuous workstations side by side, using common end leg structures in lieu of individual tables.
- This system can be used with single sided C-Frame tables or double sided island tables.
- Like the individual C-Frame tables, bottom shelves, mobile or suspended cabinets can be used with the system.
- Order brackets, shelving, counter tops, and accessories separately.

### How to design and order HLF Add-a-Bench systems.

- Start with the C-Frame tables on the previous pages.
- Add additional adder benches from the lists below.
- Adder benches can be different widths but need to be the same style and counter height.
- Add table accessories.

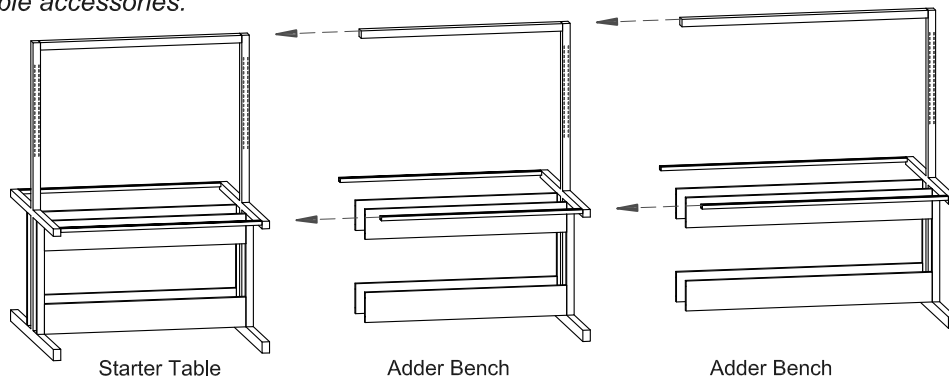

### Double Sided Island Adder Benches

29-3/4" high tables with Shelf Upright Posts.

Model	Table Frame		Top Size
	Width	Depth	
CFTU34D29ADD	34"	58"	36" x 60"
CFTU46D29ADD	46"	58"	48" x 60"
CFTU58D29ADD	58"	58"	60" x 60"
CFTU70D29ADD	70"	58"	72" x 60"

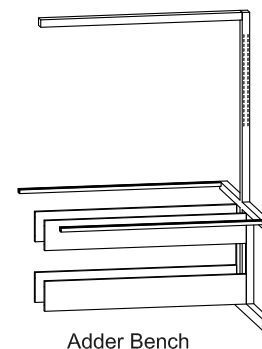

### Double Sided Island Adder Benches

35-3/4" high tables with Shelf Upright Posts.

Model	Table Frame		Top Size
	Width	Depth	
CFTU34D35ADD	34"	58"	36" x 60"
CFTU46D35ADD	46"	58"	48" x 60"
CFTU58D35ADD	58"	58"	60" x 60"
CFTU70D35ADD	70"	58"	72" x 60"

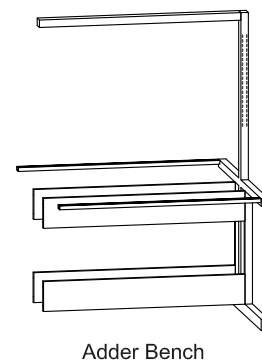

# Mobile Cart Workstations

## Mobile Cart Workstations

Mobile cart workstations provide maximum flexibility to your room layout. Starting with the basic cart and adjustable height cantilevered counter support frame, you can customize your workstation with a variety of accessories found on the next few pages to create the exact instrument cart or workstation you require.

- Heavy duty construction with locking casters.
- Counter tops are adjustable in height in 1" increments.
- Mobile or suspended cabinets, shelves and table accessories must be ordered separately.
- Shipped KD (knocked down) for field assembly.

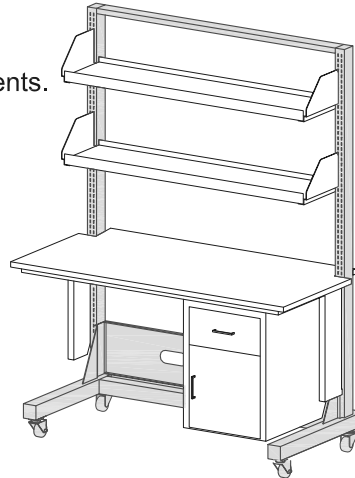
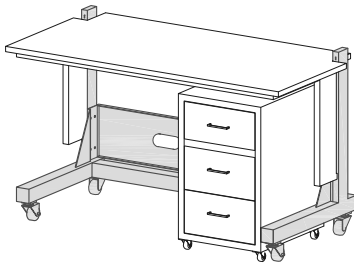
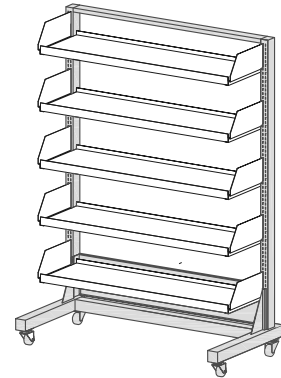

## Lower Cart Workstations 36" High

- Counter top is adjustable to Regular, ADA, or low height.

Model	Top Size Width	Table Width
MCW3636	36"	34"
MCW4836	48"	46"
MCW6036	60"	58"
MCW7236	72"	70"

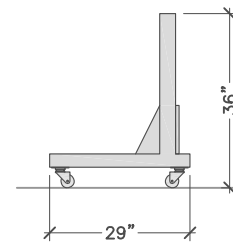
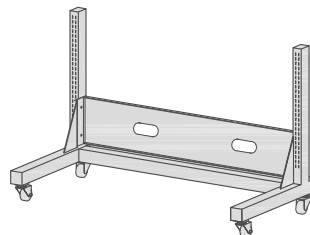

## Full Height Cart Workstations 78" High

- Counter top is adjustable to Regular, ADA, or low height.

Model	Top Size Width	Table Width
MCWU3678	36"	34"
MCWU4878	48"	46"
MCWU6078	60"	58"
MCWU7278	72"	70"

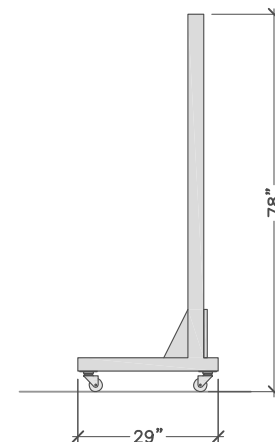
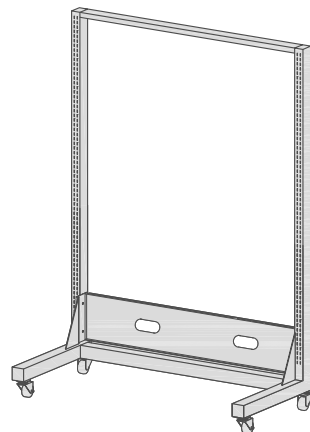

### Cantilevered Counter Table Frames

- Vertically adjustable counter tops in 1" increments.
- Table frames are available to support 30" or 36" deep counter tops.

Model	Top Size		Counter Depth
	Width	Depth	
CTF36A	36"	22-3/4"	30"
CTF48A	48"	22-3/4"	30"
CTF60A	60"	22-3/4"	30"
CTF72A	72"	22-3/4"	30"
CTF36B	36"	28-3/4"	36"
CTF48B	48"	28-3/4"	36"
CTF60B	60"	28-3/4"	36"
CTF72B	72"	28-3/4"	36"

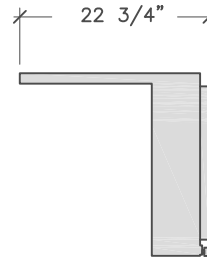
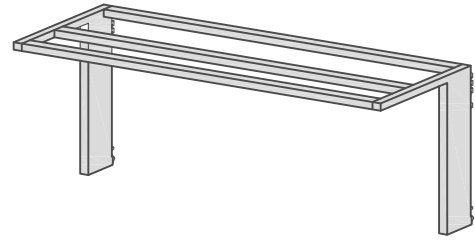

22-3/4" depth frames are used with 30" deep counter tops.

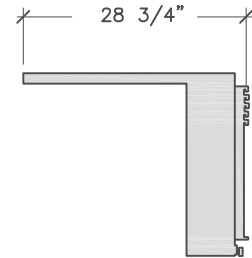

28-3/4" depth frames are used with 36" deep counter tops.

### Bottom Cart Shelf

- The painted steel cart shelf is 24" deep and includes a cross brace support.

Model	Cart Size	Shelf Depth
CT36	36"	24"
CT48	48"	24"
CT60	60"	24"
CT72	72"	24"

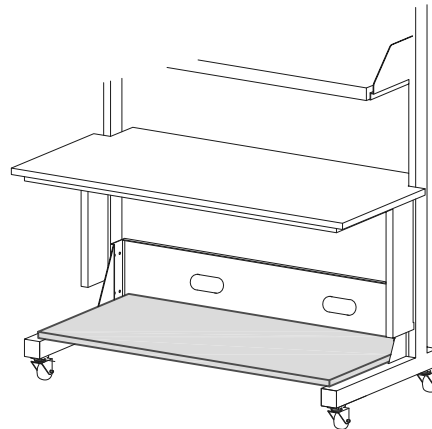

### Leg Levelers

- Leg levelers are used to lift the table above the caster wheels when less table movement is desired.

#### Model

CLL-4 (Includes a set of 4)

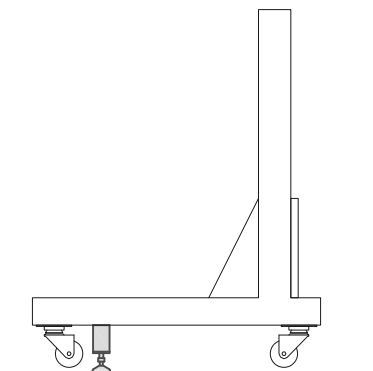

### Shelving Styles, Sizes, and Applications

Shelving styles on this page are used with the following table applications:

- AHTU - Adjustable Height Tables
- CFTU - C-Frame Tables
- HDWU - Heavy Duty Welded Tables
- MCWU - Mobile Cart Workstations

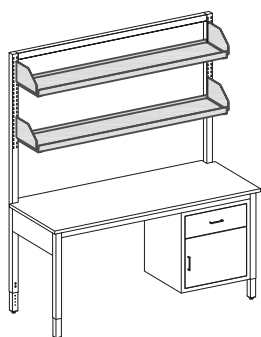
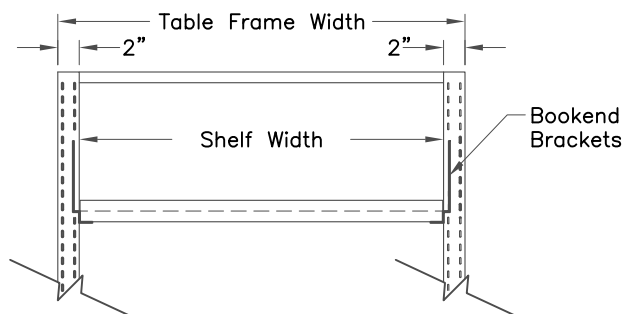

AHTU Tables  
Adjustable Height

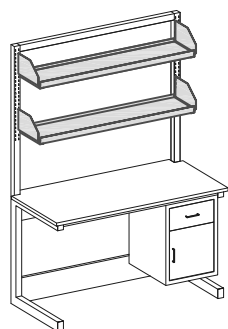

CFTU Tables  
C-Frame

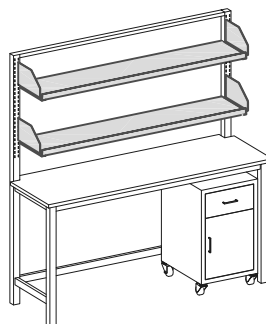

HDWU Tables  
Heavy Duty

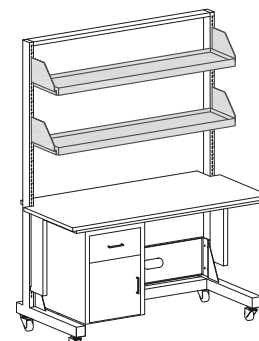

MCWU Carts  
Mobile Workstations

### Plastic Laminate Table Shelving - TPL

### Phenolic Resin Table Shelving - TPR

- 1" thick laminate shelves with 1" high front 3mm PVC retainer lip (black).
- 3/4" thick black phenolic shelves with front retainer lip. Contact your HLF representative for material options for retainer lips.
- Center bracket and additional wall standard required for shelves 60" and over for laminate or phenolic shelves.
- Specify TPL for laminate or TPR for phenolic shelves at the beginning of the model numbers below.

Model	Table Frame Width	Shelf Width	Shelf Depth
___3412	34"	30"	12"
___4612	46"	42"	12"
___5812	58"	54"	12"
___7012	70"	66"	12"
___3414	34"	30"	14"
___4614	46"	42"	14"
___5814	58"	54"	14"
___7014	70"	66"	14"
___3416	34"	30"	16"
___4616	46"	42"	16"
___5816	58"	54"	16"
___7016	70"	66"	16"

### Painted Steel Table Shelving - TMS

- 1" thick 16 ga. painted steel with front retainer lip.
- Available in HLF standard colors to match casework.

Model	Table Frame Width	Shelf Width	Shelf Depth
TMS3412	34"	30"	12"
TMS4612	42"	42"	12"
TMS5812	58"	54"	12"
TMS7012	70"	66"	12"
TMS3414	34"	30"	14"
TMS4614	46"	42"	14"
TMS5814	58"	54"	14"
TMS7014	70"	66"	14"
TMS3416	34"	30"	16"
TMS4616	46"	42"	16"
TMS5816	58"	54"	16"
TMS7016	70"	66"	16"

### Shelf Retainer Lips - LIP

- Painted metal shelf lips attach to underside of shelf.

Model - specify shelf width

LIP - \_\_\_\_\_

### Bookend Brackets

- Offset style bookend brackets are 7" high, 12 ga. painted steel.

Model	Size	Used with:
HDB11	11" D	12" D shelves
HDB13	13" D	14" D shelves
HDB15	15" D	16" D shelves

Model number includes a set of Left and Right hand brackets.

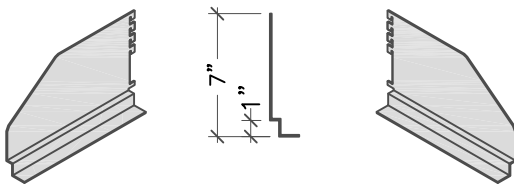

### Table Caster Kit

- Available for Adjustable Height and C-frame tables.
- Includes a set of 4 swivel locking stem casters.
- Casters add 3-1/4" to table height.

Model
CLM3T2

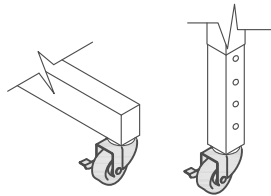

### Power Outlet Strips

- Mounts to table upright posts.
- 15 amp 120 volt electrical plugs with built in on/off switch and circuit breakers.
- Prewired with electrical cord and plug.
- UL approved. Color: Gray
- Mounting hardware included.

Model	Size	Table Frame
		Width
POS3	36"	34"
POS4	48"	46"
POS5	60"	58"
POS6	72"	70"

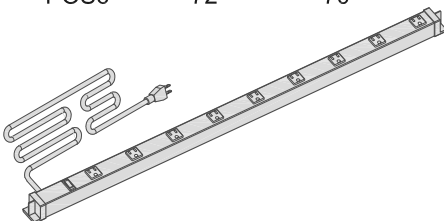

### Reverse Top Brackets

- Used to place a shelf at the top of the upright post.
- Reversed offset style bookend brackets are 5" high, 12 ga. painted steel.

Model	Size	Used with:
RHDB11	11" D	12" D shelves
RHDB13	13" D	14" D shelves
RHDB15	15" D	16" D shelves

Model number includes a set of Left and Right hand brackets.

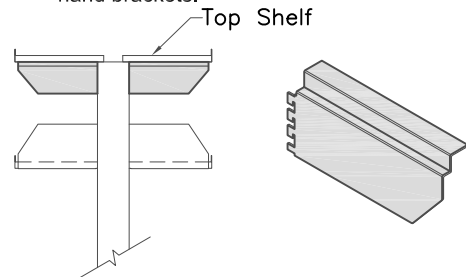

### Suspended Cabinet Kit

- SCK kits include a front J track and an intermediate rail with a J track that are required to suspend cabinets on Agility tables.

Model	Table Width
SCK3	34"W
SCK4	46"W
SCK5	58"W
SCK6	70"W

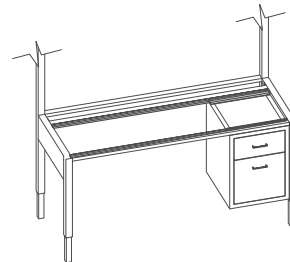

### Mounting Clips

- Used to mount accessories onto table upright posts or island adjustable shelving units.
- Sold in sets of two.

Model
MC2

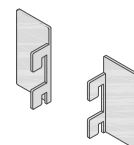



### Keyboard Trays and Sliding Keyboard Shelves

- HLF offers a variety of under counter keyboard trays and sliding keyboard systems compatible with our table designs.

Contact your HLF representative for additional information on available styles.

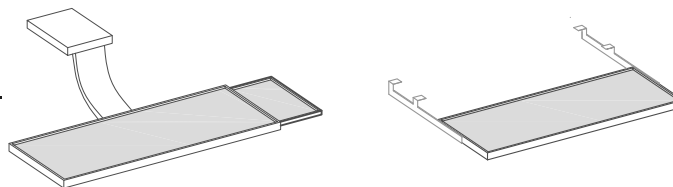

### Vinyl Tackboards

- Can be mounted on a wall or on tables with upright posts.
- Treated to resist the growth of odor and stain causing microbes.
- Mounting clips for table uprights are included.

Model	Width	Height
TB3415	34"	15"
TB4615	46"	15"
TB5815	58"	15"
TB7015	70"	15"
TB3418	34"	18"
TB4618	46"	18"
TB5818	58"	18"
TB7018	70"	18"
TB3424	34"	24"
TB4624	46"	24"
TB5824	58"	24"
TB7024	70"	24"

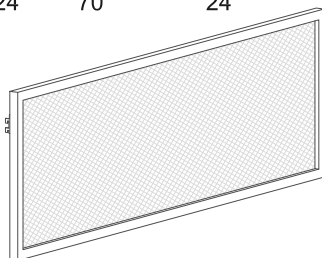

### Marker Boards

- Porcelain-on-steel boards create a durable non-porous, scratch-resistant surface.
- Can be mounted on a wall or on table upright posts.
- Mounting clips for table uprights are included.

Model	Width	Height
MB3415	34"	15"
MB4615	46"	15"
MB5815	58"	15"
MB7015	70"	15"
MB3418	34"	18"
MB4618	46"	18"
MB5818	58"	18"
MB7018	70"	18"
MB3424	34"	24"
MB4624	46"	24"
MB5824	58"	24"
MB7024	70"	24"

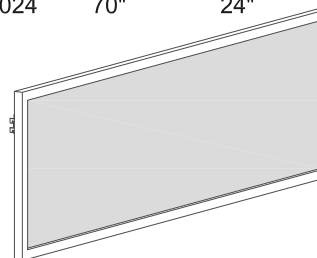

### Top Center Panels

- Used as a visual barrier on table upright posts.
- Mounting clips are included.

Model	Table Frame	
	Width	Height
TCP3415	34"	15"
TCP3418	34"	18"
TCP3424	34"	24"
TCP4615	46"	15"
TCP4618	46"	18"
TCP4624	46"	24"
TCP5815	58"	15"
TCP5818	58"	18"
TCP5824	58"	24"
TCP7015	70"	15"
TCP7018	70"	18"
TCP7024	70"	24"

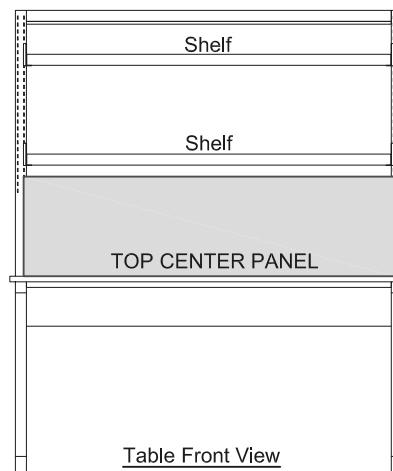

# Suspended Cabinets

Height - 21"

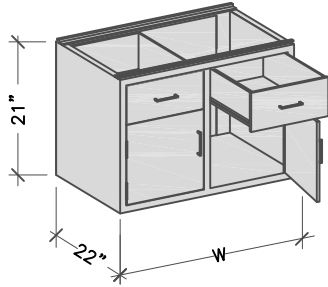

## The HLS Advantages:

- Inset steel - flush face construction.
- For use with HLS Agility Adaptable & HDW tables.
- Suspended cabinets are 21" h. and 22"d. Widths as shown below.
- Open and cupboard cabinets have two adjustable shelves.
- For locks, specify -LK at the end of the product number.
- Cabinets can be removed, relocated, or moved to any location on the table chosen.
- Suspended cabinets have finished backs and include cabinet attachment brackets.

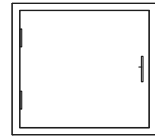
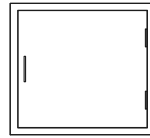
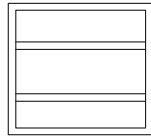

With HLS's unique track support system, suspended cabinets can be repositioned, left to right, to any place on the table or removed to another location.

MODEL	WIDTH
AJ15U	15"
AJ18U	18-1/8"
AJ24U	24-1/8"

Model	Width
AA15U	15"
AA18U	18-1/8"
AA24U	24-1/8"

Model	Width
AA15UL	15"
AA18UL	18-1/8"
AA24UL	24-1/8"

L = Left Hinged Door

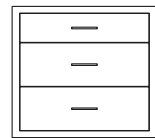
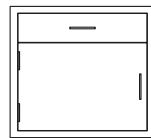
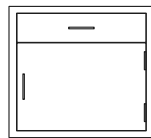
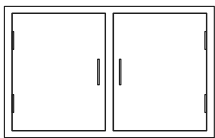

Model	Width
DA30U	30"
DA35U	35"
DA42U	42"

Model	Width
AB15U	15"
AB18U	18-1/8"
AB24U	24-1/8"

Model	Width
AB15UL	15"
AB18UL	18-1/8"
AB24UL	24-1/8"

L = Left Hinged Door

Model	Width
AF18U	18-1/8"
AF24U	24-1/8"

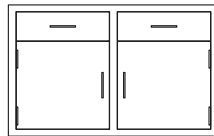
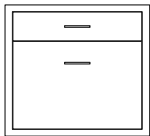

Model	Width
AG18U	18-1/8"
AG24U	24-1/8"

Model	Width
DD30U	30"
DD35U	35"
DD42U	42"

# Mobile Cabinets

Low Height - 25-1/4"

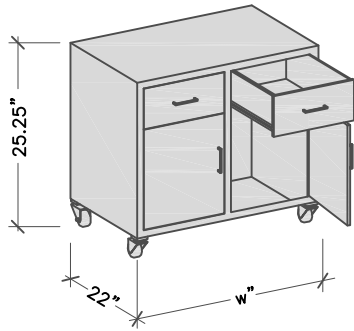

**Note:**

Low height mobile cabinets are compatible with HLS low height table systems.

**The HLS Advantages:**

- Inset steel - flush face construction.
- Painted steel top and finished backs are standard.
- Mobile height cabinets are 25-1/4" h. and 22" d. Widths as shown below.
- Open cupboard cabinets have 2 adjustable shelves.
- Cupboard cabinets have one adjustable shelf.
- For locks on drawers and doors specify -LK at the end of the product number.
- 3" dia. wheels on 4-1/4" h. casters.
- Front casters swivel, with brake. Rear casters fixed, no brake
- Optional counter tops are available. Specify the material type and thickness. Add the thickness to the mobile cabinet height.

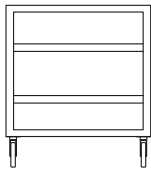

Model	Width
AJ15LM	15"
AJ18LM	18-1/8"
AJ24LM	24-1/8"

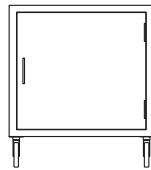

Model	Width
AA15LM	15"
AA18LM	18-1/8"
AA24LM	24-1/8"

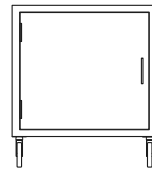

Model	Width
AA15LML	15"
AA18LML	18-1/8"
AA24LML	24-1/8"

L = Left Hinged Door

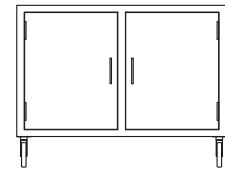

Model	Width
DA30LM	30"
DA35LM	35"
DA42LM	42"

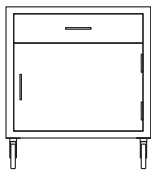

Model	Width
AB15LM	15"
AB18LM	18-1/8"
AB24LM	24-1/8"

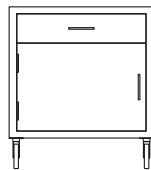

Model	Width
AB15LML	15"
AB18LML	18-1/8"
AB24LML	24-1/8"

L = Left Hinged Door

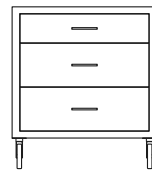

Model	Width
AF18LM	18-1/8"
AF24LM	24-1/8"

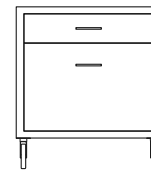

MODEL	WIDTH
AG18LM	18-1/8"
AG24LM	24-1/8"

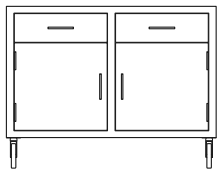

Model	Width
DD30LM	30"
DD35LM	35"
DD42LM	42"

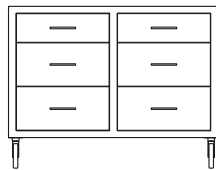

Model	Width
DT30LM	30"
DT35LM	35"
DT42LM	42"

# Mobile Cabinets

Standard Height - 32 1/2"

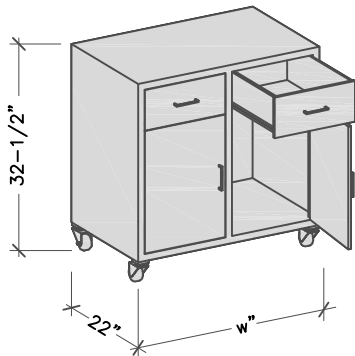

## The HLS Advantages:

- Inset steel - flush face construction.
- Painted steel top and finished backs are standard.
- Mobile height cabinets are 32-1/2"h. and 22"d. Widths as shown below.
- Open cupboard cabinets have 2 adjustable shelves.
- Cupboard cabinets have one adjustable shelf.
- For locks on drawers and doors specify -LK at the end of the product number.
- 3" dia. wheels on 4-1/4" h. casters.
- Front casters swivel, with brake. Rear casters fixed, no brake
- Optional counter tops are available. Specify the material type and thickness. Add the thickness to the mobile cabinet height.

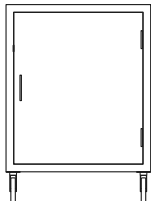

Model	Width
AA15HM	15"
AA18HM	18-1/8"
AA24HM	24-1/8"

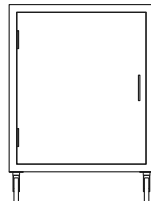

Model	Width
AA15HML	15"
AA18HML	18-1/8"
AA24HML	24-1/8"

L = Left Hinged Door

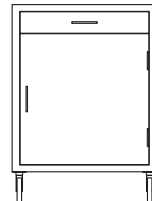

Model	Width
AB15HM	15"
AB18HM	18-1/8"
AB24HM	24-1/8"

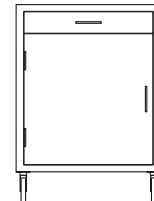

Model	Width
AB15HML	15"
AB18HML	18-1/8"
AB24HML	24-1/8"

L = Left Hinged Door

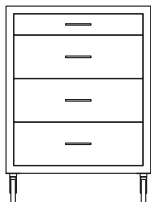

Model	Width
AF15HM	15"
AF18HM	18-1/8"
AF24HM	24-1/8"

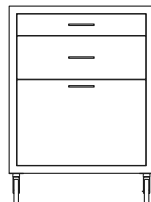

Model	Width
AG18HM	18-1/8"
AG24HM	24-1/8"

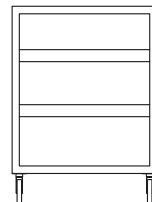

Model	Width
AJ15HM	15"
AJ18HM	18-1/8"
AJ24HM	24-1/8"

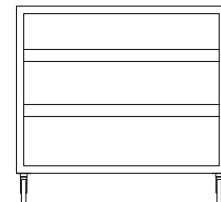

Model	Width
DY30HM	30"
DY35HM	35"
DY42HM	43"
DY47HM	47"

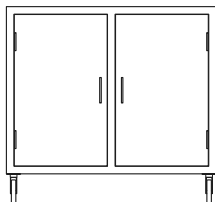

Model	Width
DA30HM	30"
DA35HM	35"
DA42HM	43"
DA47HM	47"

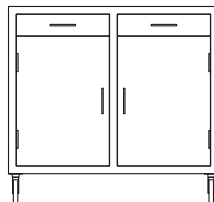

Model	Width
DD30HM	30"
DD35HM	35"
DD42HM	43"
DD47HM	47"

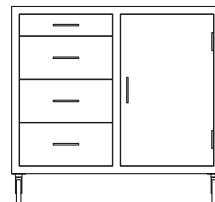

Model	Width
DG30HM	30"
DG35HM	35"
DG42HM	43"
DG47HM	47"

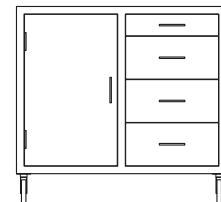

Model	Width
DG30HMLC	30"
DG35HMLC	35"
DG42HMLC	42"
DG47HMLC	47"

LC = Left Cupboard Door

# Mobile Cabinets

## Standard Height - 32 1/2"

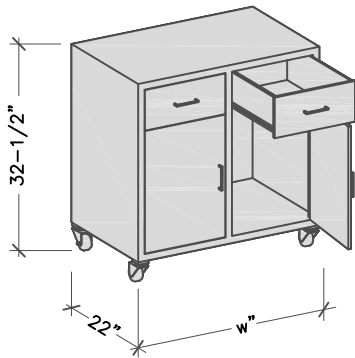

### The HLS Advantages:

- Inset steel - flush face construction.
- Painted steel top and finished backs are standard.
- Mobile height cabinets are 32-1/2"h. and 22"d. Widths as shown below.
- Open cupboard cabinets have 2 adjustable shelves.
- Cupboard cabinets have one adjustable shelf.
- For locks on drawers and doors specify -LK at the end of the product number.
- 3" dia. wheels on 4-1/4" h. casters.
- Front casters swivel, with brake. Rear casters fixed, no brake
- Optional counter tops are available. Specify the material type and thickness. Add the thickness to the mobile cabinet height.

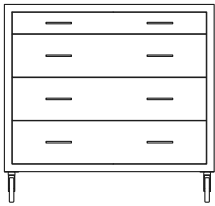

Model	Width
CF30HM	30"
CF35HM	35"
CF42HM	43"
CF47HM	47"

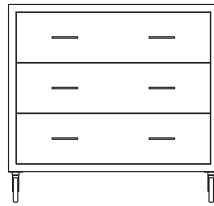

Model	Width
CP30HM	30"
CP35HM	35"
CP42HM	43"
CP47HM	47"

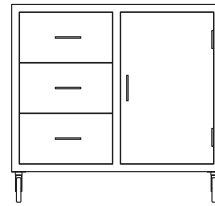

Model	Width
CG30HM	30"
CG35HM	35"
CG42HM	43"
CG47HM	47"

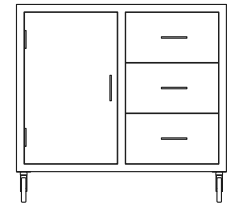

Model	Width
CG30HMLC	30"
CG35HMLC	35"
CG42HMLC	42"
CG47HMLC	47"

LC = Left Cupboard Door

# Overhead Service Carriers

## Function & Design

- HLF offers a variety of service carrier styles to fit various applications and price points. They can be especially functional when used with our mobility table and mobile line of lab furniture.
- Service carriers deliver ceiling-fed utilities at predetermined locations.
- Service valves or quick disconnects as well as electrical and data ports are available in multiple combinations for all service carriers.
- Order service fixtures and electrical / data components separately.
- *Contact your HLF representative for more information on choosing overhead service carriers designed to your laboratory plan and budget.*



## Ceiling Service Panels

- Designed to fit inside a standard 2' x 2' ceiling tile grid when service connection from the ceiling is desired.
- Painted steel panel construction.
- Service panels may be customized to meet your project requirements.
- Order service fixtures and electrical / data components separately.

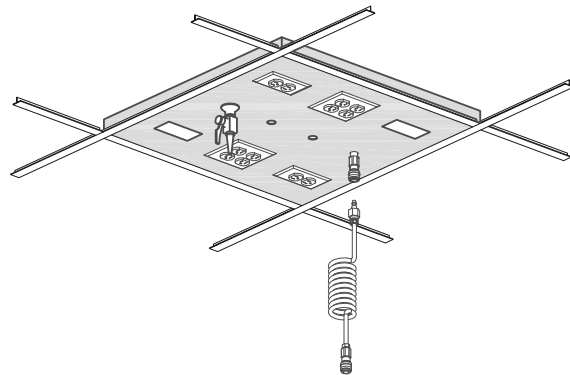

## Vertical Service Carriers

- Drop down single point carrier.
- Available in 16" wide x 16" deep carriers. 3', 4', and 5' high carriers available.
- A structural support system, (not included) for attachment to the building is required for installation.
- Order service fixtures and electrical / data components separately.

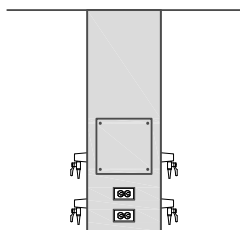
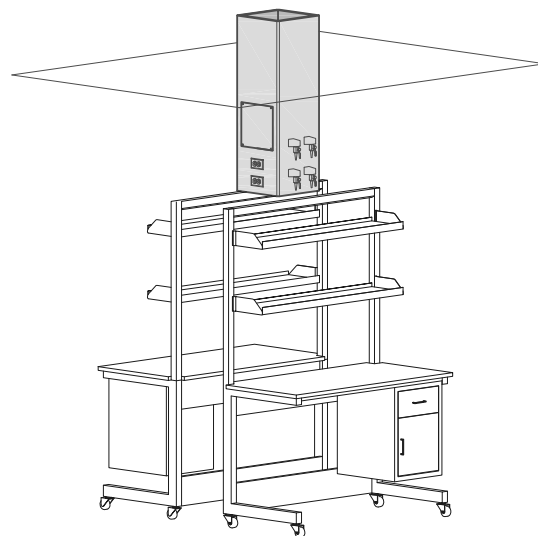

Front View

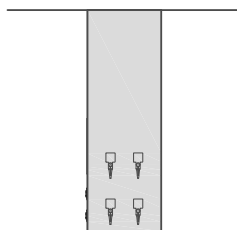

Side View

# Umbilical Pipe Enclosures / Service Panels

## Function & Design

- HLF offers a variety of Umbilical Pipe Enclosures used to conceal service lines that come down from the ceiling at either walls or at island locations. Floor to ceiling models are also available.
- Umbilicals are also available with service panels.
- One side of enclosure is removable for access to utilities.
- Painted steel construction to match the cabinets.
- Custom sizes are available.

## Wall Bench Umbilicals

Model	Width	Depth
UMW12	12"	6"
UMW18	18"	6"
UMW24	24"	6"

Note: A verified ceiling height is required to determine the correct umbilical height.

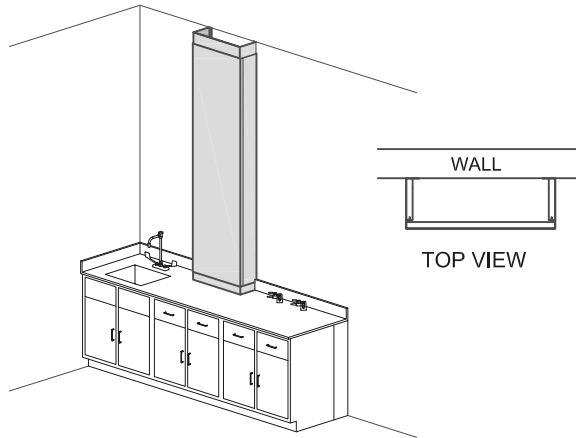

## Island Bench Umbilicals

Model	Width	Depth
UMI12	12"	6"
UMI18	18"	6"
UMI24	24"	6"

Note: A verified ceiling height is required to determine the correct umbilical height.

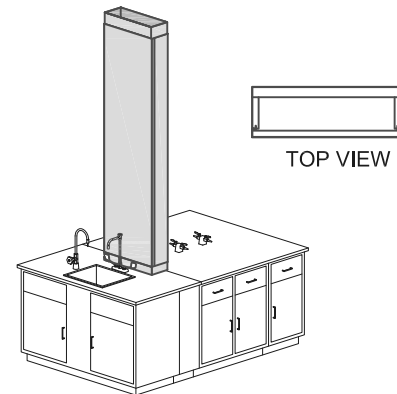

## Umbilical Pipe Enclosures with Service Panels

- Wall or island bench umbilicals that are fitted with service panels for electrical, data and service fittings.
- They can be especially functional when used with our mobile line of lab furniture.
- Order electrical / data and service fixture types and quantities separately.
- *Contact your HLF representative for more information on choosing service panels and fixtures designed to your laboratory plan.*

To add a service panel to any wall or island bench umbilical, add -SP to the end of the model number.

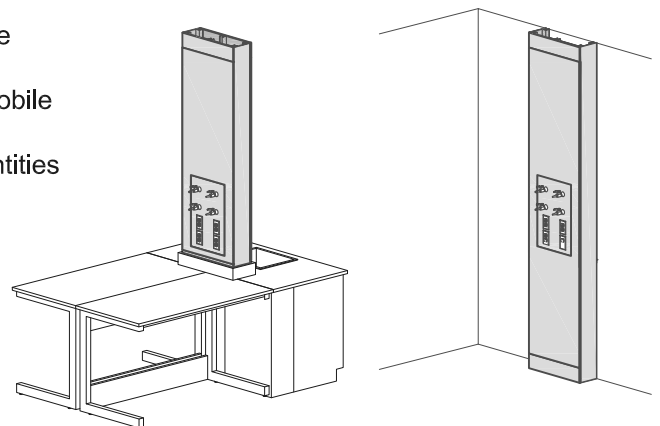

### Function & Design

- HLF offers a variety of service carrier styles to fit various applications and price points. They can be especially functional when used with our mobility table and mobile line of lab furniture.
- Service carriers deliver ceiling-fed utilities at predetermined locations.
- Service valves or quick disconnects as well as electrical and data ports are available in multiple combinations for all service carriers.
- Order service fixtures and electrical / data components separately.
- *Contact your HLF representative for more information on choosing overhead service carriers designed to your laboratory plan and budget.*

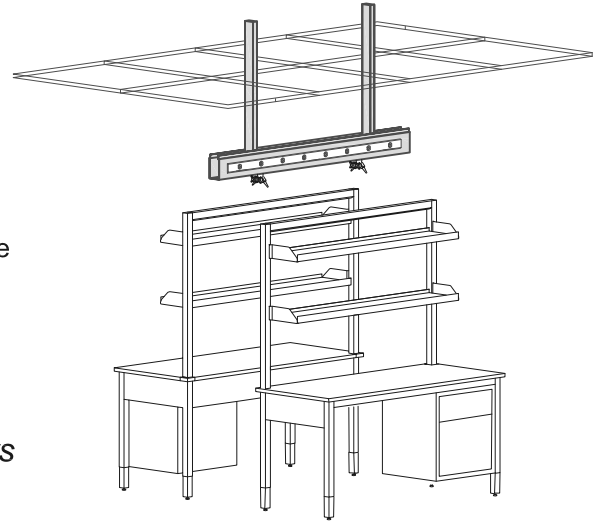

### Horizontal Service Carriers

- Horizontal style overhead service carriers can deliver electrical, data, and plumbing services from above.
- Provided in 4', 5', 6', and 8' widths, and can be ganged end to end for continuous runs.
- Included is a drop down vertical service chase and two painted steel strut pieces to connect to the building or other building supports.
- A structural support system, (not included) for attachment to the building is required for installation.
- Electrical / data wire mold supplied and installed by others.

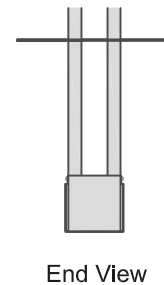
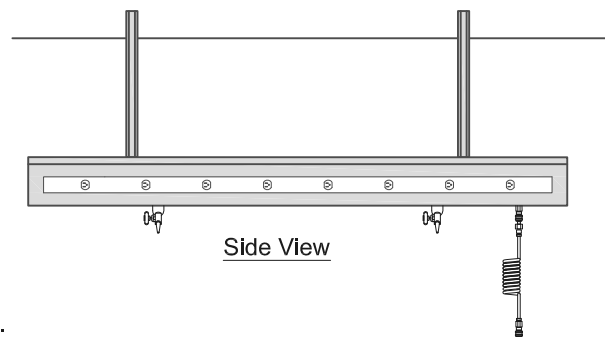



## Function & Design

- HLF offers a variety of service carrier styles to fit various applications and price points. They can be especially functional when used with our mobility table and mobile line of lab furniture.
- Service carriers deliver ceiling-fed utilities at predetermined locations.
- Service valves or quick disconnects as well as electrical and data ports are available in multiple combinations for all service carriers.
- Order service fixtures and electrical / data components separately.
- *Contact your HLF representative for more information on choosing overhead service carriers designed to your laboratory plan and budget.*

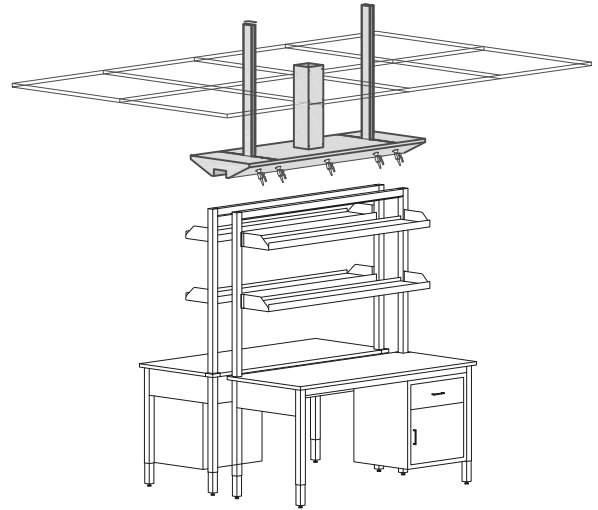

## Horizontal Service Carriers

- Horizontal style overhead service carriers can deliver electrical, data, and plumbing services from above.
- Provided in 4', 5', 6', and 8' widths, and can be ganged end to end for continuous runs.
- Included is a drop down vertical service chase and two painted steel strut pieces to connect to the building or other building supports.
- A structural support system, (not included) for attachment to the building is required for installation.
- Electrical / data wire mold supplied and installed by others.

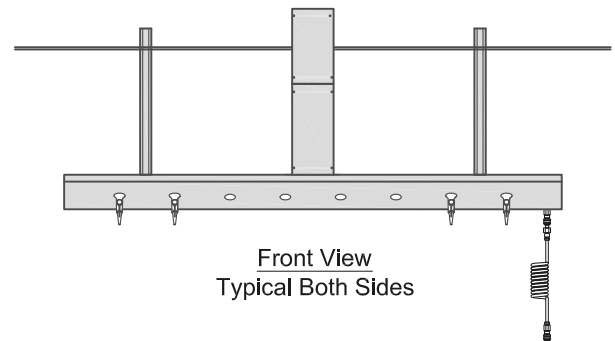

Front View  
Typical Both Sides

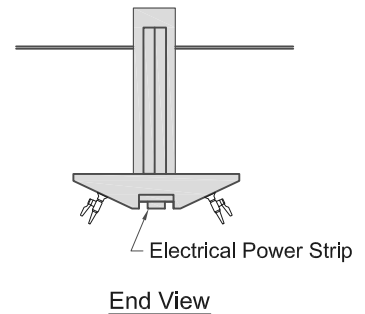



# Where To Find HLS

Our Lab Professionals Serve Customers Throughout The U.S.

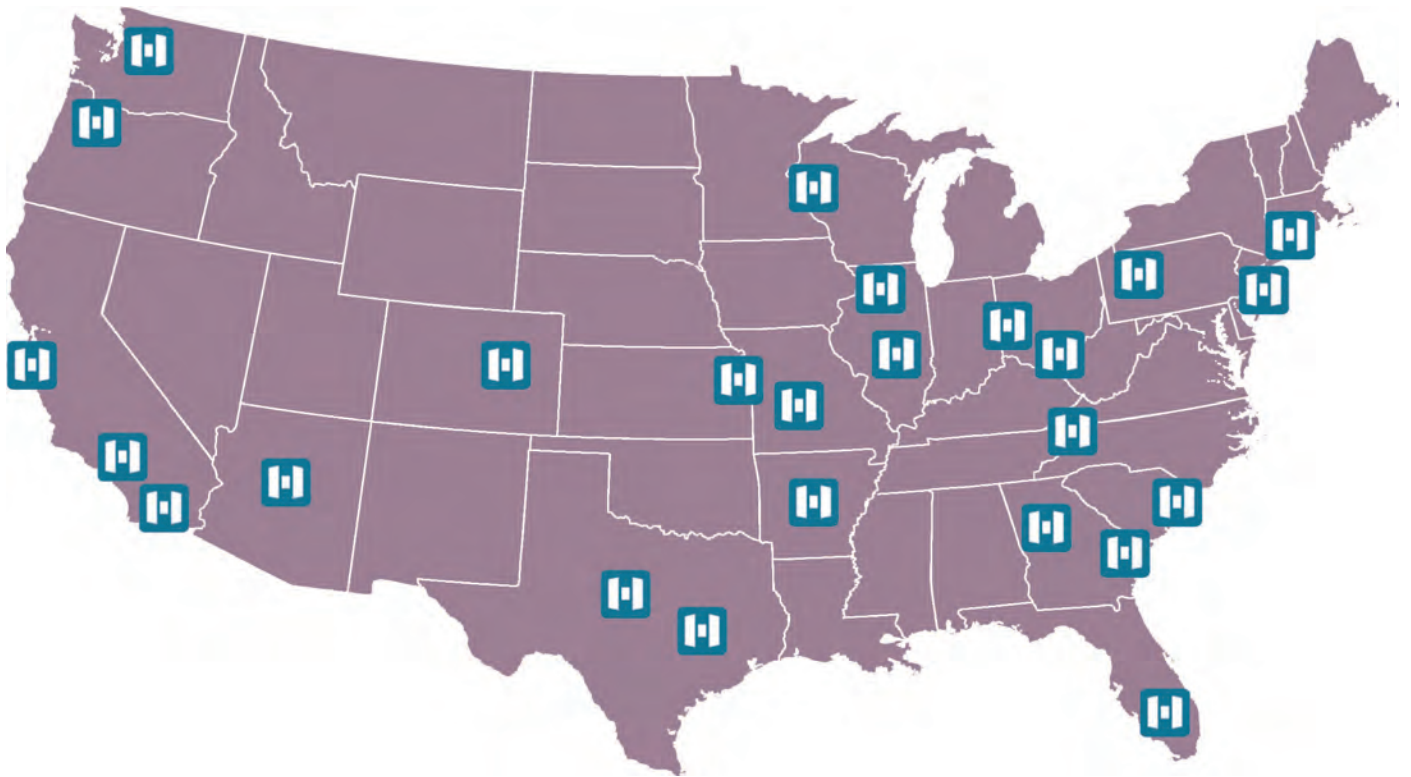

## Here's what we deliver to our customers:

- Design and conceptual planning
- Installation
- Engineering
- National HLS representation with project management and installation support
- Support for engineers and contractors. Let us help you develop your new lab.
- Ideas and suggestions for how to do it better, faster, and cheaper
- Custom looks for standard costs: if you want a custom lab, we can show you how you may be able to achieve the same look with custom configuration of standard products.
- And if you really need custom pieces, we're vertically integrated, with design, manufacturing, and expert installation in one company. So we are likely to be able to deliver custom furniture and fume hoods at lower costs than you might expect.
- The fastest delivery in the industry. In every category. Period.

Ready to get started? We're here to serve you.

Call us at 1-805-498-3121  
Email us at [info@hansonlab.com](mailto:info@hansonlab.com)  
Or call your HLS representative