



# 2024 LAB FURNITURE CATALOG

Manufacturer of Laboratory Steel Casework, Workbenches,  
Adaptable Furniture Systems and Fume Hoods.

# ABOUT HLS



## Over 20,000 Laboratories Created

With a legacy of over 50 years, HLS has built a remarkable track record of collaboration with contractors, scientists, and technicians, contributing to the development of over 20,000 laboratories across the nation. Our extensive product range, which encompasses laboratory tables, cabinets, fume hoods, and accessories, offers unparalleled versatility to cater to the evolving needs of tomorrow's labs. We stand at the forefront of the industry when it comes to adaptable furniture, exemplified by our M-Series, known for its remarkable adaptability while remaining highly cost-effective, and our Agility Systems, renowned for its exceptional load-bearing capacity and unparalleled durability.

As a full-service manufacturer, HLS provides a seamlessly integrated supply chain that spans from initial planning with our lab specialists through assembly to installation. This unique approach delivers an unparalleled combination of speed, service, innovation, and value to our customers.

### Have projects on a tight timeline?

Hanson Express allows customers to receive products promptly. We boast an impressive inventory of over 1,000 Linear Feet ready for immediate shipping. Look for the Hanson Express Logo next to the model number for items ready for immediate shipping (*quantities will vary*).



### No Cost Lab Planning Help

Why go it alone when you can have expert help at no additional cost? We'll be glad to help you with your laboratory design. From your overall laboratory plan to your specific workstation requirements, our representatives can help you design your lab in the most economical way possible, using a balance between fixed and flexible casework options. Give us a call. We're glad to help.

### How To Use This Catalog

#### Product Organization

Use our quick index or browse through the major project sections to find what you need. Sections are organized by product group for easy identification.

### Ready to get started?

Call us at 1-805-498-3121.

Email us at [info@hansonlab.com](mailto:info@hansonlab.com) or call your HLS representative.

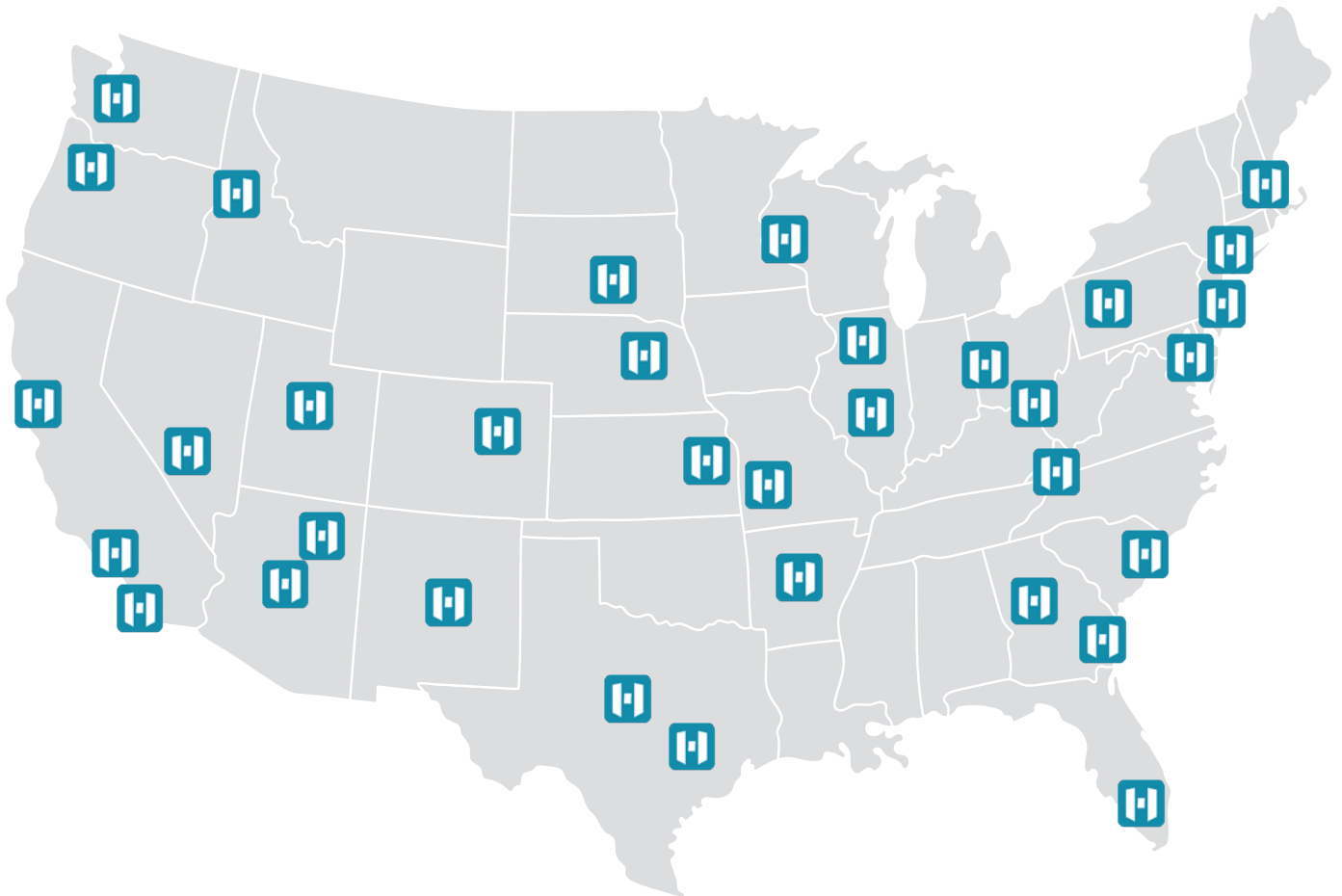

*Over the years, we have had the privilege of contributing to the design and functionality of more than 20,000 laboratories.*



### On-time Delivery

100% on-schedule delivery and in-stock product delivered typically at half the time of industry standards



### Unbeatable Service

One-stop resource: planning, design, assembly and transportation



### Unparalleled Quality

In house precision manufacturing and assembly. Highest load capacity and most durable products on the market



	Page
<b>About HLS</b> .....	2
<b>Lab Planning 101</b> .....	6
<b>Steel Casework*</b> .....	10
<i>Infinite Combinations for any lab.</i>	
• Steel Cabinet Details .....	11
• Standing Height Cabinets .....	13
• Sitting Height Cabinets .....	19
• ADA Height Cabinets .....	25
• Suspended Cabinets .....	29
• Mobile Cabinets .....	30
• Chemical Storage Cabinets .....	32
• Specialty Cabinets .....	38
• Casework Accessories, Fillers, Aprons .....	42
• Wall Cabinets .....	50
• Tall Cabinets .....	61

*\*Laminate and wood may also be available.  
Contact your HLS Sales representative for more details*

<b>Adaptable Furniture and Tables</b> .....	69
<i>Maximum flexibility with mobile and modular systems.</i>	
• Adaptable Furniture & Table Comparison Chart .....	70
• Agility Workstations .....	71
• Agility Mobile .....	71
• Agility Adaptable .....	72
• Agility Essential .....	73
• Agility Service Hub .....	75
• M-Series Workstations .....	79
• Features and Options .....	79
• Heavy-Duty Welded Tables .....	88
• Utility Tables .....	98
• Accessories .....	99
• Table Accessories .....	99
• Ceiling Service Panels and Couplers .....	101

<b>Shelving**</b> .....	103
<i>Make the most of square footage with vertical storage.</i>	
• Wall Standards .....	104
• Shelf Brackets .....	104
• Island Systems .....	105
• Individual Shelves .....	107
• Shelving Accessories .....	112

*\*\*Alternate shelving materials and styles may also be available.  
Contact your HLS Sales representative for more details*

	Page
<b>Laboratory Fixtures &amp; Accessories</b> .....	113
<i>Everything you need to complete your lab.</i>	
• Laboratory Service Fixtures .....	114
• Sinks and Accessories .....	121
• Electrical Fixtures .....	124
• Pegboards .....	125
• Drip Trays, Soap/Towel Dispensers .....	126
• Countertops / Work Surfaces .....	127

<b>Fume Hoods</b> .....	128
<i>Benchtop, floor-mounted, and custom configurations, with the fastest fume hood shipping times in the industry</i>	
• About HLS Fume Hoods .....	129
• Sash Designs .....	130
• Operating Types .....	132
• 5SA Series: Benchtop Mount .....	133
• Dimensional Data .....	133
• General Purpose .....	134
• Hi-Line .....	135
• ADA .....	136
• 4SA Series: Floor-Mount Fume Hoods .....	137
• Dimensional Data .....	137
• Vertical Sash .....	138
• Horizontal Sash .....	139
• Options and Accessories .....	140

<b>Hanson Express</b> .....	151
<i>In stock and ready to ship in as little as 72 hours.</i>	
• Steel Casework .....	152
• Base Cabinets .....	152
• Wall, Sink, and Tall Cabinets .....	153
• Mobile Cabinets .....	154
• Tables and Workstations .....	157
• M-Series Workstations & Countertops .....	157
• Utility Tables .....	159
• Laboratory Fixtures and Accessories .....	162
• Shelving .....	164
• Fume Hoods .....	166

## Tips to Build a Better Lab

Whether this is your first lab, or you've built dozens of them, we hope you'll find these tips and ideas valuable in your approach to designing the best possible lab at the best overall cost. And you'll find that your new lab will be better equipped to accommodate changing laboratory requirements later, especially with cost-effective flexibility solutions like our M-Series, Mobile and Shelving product lines.

### 1. Plan Thoughtfully

**Before you begin, get educated about the process. You need to know...:**

- The needs and expectations of functional group managers and other internal team members.
- The expertise and capabilities of your external team, including architects, engineers, construction managers, contractors, and lab planners.
- Your realistic and current needs for space, processes, support areas, and materials storage. Plans made on assumptions mean that you could make costly mistakes. Plans made on projected growth can get expensive very quickly if HVAC, power, and workspace are added prematurely. And the fact is that most well-planned labs can easily accommodate change when needed.

### 2. Keep Your Layout Simple

- Minimize or eliminate walls between functions.
- Organize functional groups in shared space. It's cheaper to build now and is more flexible later.
- Use islands and peninsulas to maximize your usable space. Putting benches only around the perimeter wastes as much as 75% of your square footage.



### 3. Establish “Wet Walls”

- Place sinks along walls with existing plumbing services, where possible.
- Keep sinks in close proximity to process and research needs.
- Dedicate a sink for hand washing near the entry/exit of lab.
- Avoid putting sinks on islands or peninsulas. It's harder to install, and costly to reconfigure.

### 4. Specify 3 ft. and 4 ft. Cabinets and Wall Cases

- A 36” or 48” cabinet only costs 30% more than an 18” or 24” cabinet.
- Using 3’ and 4’ cabinets whenever possible gives you more storage and workspace per linear foot for less money.



## 5. Choose Open Wall Shelving

- More cost effective per linear foot.
- Can be deeper, taller, and hold more.
- Easily accessible above all workstations.

**TIP: Use adjustable height shelving on islands and peninsulas. HLS systems cost about the same as fixed and give users much more flexibility.**

## 6. Simplify and Standardize

- Decide on the appropriate casework configuration for your lab, and then save by repeating throughout your building.
- Hanson systems include fixed steel casework, mobile and flexible furniture options. They work together in unlimited combinations.
- Standardize design with repeated configurations. It looks great, it's cost efficient for architects, contractors, and MEP – and it's flexible in use.

## 7. Be Smart About MEP

- A good layout plan drives the MEP (Mechanical, Electrical, Plumbing) plan. The MEP plan drives the cost.
- To avoid delays and cost overruns, don't specify power that exceeds current building capacity.
- For wall benches, electric, gases, and data should stay in the wall and off the countertop.
- The less plumbing you do under counter tops after the furniture is installed, the more money you'll save.
- Overhead services are best for peninsulas and islands. Penetrations through the countertop cost money. Why waste it?

# LAB PLANNING 101



## 8. Choose the Right Casework

**Conventional wisdom says that fixed cabinets cost less, but you sacrifice flexibility. But that's not always the case. Here's the rundown on different kinds of casework, and guidelines on when to use them.**

- **Fixed casework** refers to a collection of cabinets joined together to form lab bench walls, islands, and peninsulas.
- **Fixed casework** can be used with adjustable, removable shelving and reagent racks.
- **Fact:** Fixed casework door and drawer combinations can be reconfigured in installed cabinets. At HLS, we can easily accommodate changing needs in response to work group changes, new equipment requirements, or new processes. This is especially true if you choose standard sized components.
- **Application:** Fixed casework is the best combination of cost and benefit for most applications, especially along walls.
- **Modular casework** refers to cabinet systems that can be reconfigured for different needs. Modular casework is a component-based system, with more integral parts than fixed casework, like built in plumbing or electrical. In most cases, modular casework is not attached to floors or walls, and can be professionally re-installed when it's time to make a change.
- **Mobile casework** includes tables, instrument carts, and cabinets that can be moved or reconfigured as needed, often by users themselves. Mobile casework is not affixed to floors or walls. Cabinets, tables, and carts usually have wheeled casters to make moving them easier. Shelves have adjustable heights.
- **Table systems** are the most economical way to add configurability to your lab. A standard four-legged table is the basic building block. Add a flat top, a bottom shelf and caster wheels, and it's perfect for shared equipment. Add suspended or mobile cabinets underneath, and you have a workstation. Place several tables side by side, connect them with a single work surface, top them with adjustable, removable shelving or reagent racks, and you have a bench wall.
- **Fact:** A high percentage of labs designed to be changed are never reconfigured from their original footprint. A high percentage of mobile furniture is never moved once it's loaded with equipment, materials, and supplies. While the idea of a flexible lab is appealing, carefully considering actual needs and working conditions can help you put modular, mobile and flex components only where you'll really need them. And that saves money.



## 9. Be Smart About Fume Hoods

**Fume hoods are the most expensive casework in your lab. There's no doubt that they're costly to operate and maintain. But if you manage fume hoods properly, you'll save money on installation, now and for years to come.**

- Consider deeper fume hoods. Our 37" or 41" deep fume hoods have more interior working surface and equipment space, while utilizing the same air requirements as our 31" deep hoods.
- Consider the size of hoods that you'll need: 4' and 5' hoods are about the same cost per unit; 6' and 8' hoods are about the same cost per unit. You'll pay more per linear foot for smaller hoods, so choose larger hoods when you can.
- Include chemical storage safety cabinets in your plans. They make good choices as base cabinets for benchtop hoods.

### Variable Air Volume vs. Constant Air Volume?

#### Variable Air Volume (VAV) Fume Hoods:

- VAV fume hoods are primarily paired with building system controls which are tied into the main building air handling system. VAV systems are used in many newer buildings to save on energy and overall costs.
- As fume hoods are one of the largest consumers of energy, VAV systems will reduce building air exhaust when a hood is not in use, such as after-hours and weekends. This avoids pre-conditioned room air from being exhausted out of the building - which can be costly.
- When a VAV hood is in use, sensors trigger additional exhaust to be used at the fume hood, which also sends a signal to room supply air system to add more air, equal to the amount being exhausted. Over time, the VAV system will provide much greater energy and cost savings over a conventional CAV fume hood.

#### Constant Air Volume (CAV) Fume Hoods:

- CAV fume hoods are good for small applications, for dedicated exhaust, or for two to four units sharing an exhaust.

- These fume hoods generally have a "constant" rate of exhaust when in use, and are usually less energy efficient. See suggestions below for use of a 2-speed fan.

#### Hood Location Suggestions:

- Most hoods have "setup" time and "run" time, or are only used on a limited basis. While slightly more expensive to buy, that makes a two-speed exhaust more cost effective in use. Typically, low speed is 50% of high speed. Set the blower on high for setup, low for run-time, or for limited-use purposes.
- Hoods should be in close proximity to one another to save money on installing and maintaining the exhaust system.
- Try to keep fume hoods away from doorways or high traffic areas.
- Keep ceiling supply and return air ducts away from a fume hood as this can cause air flow disturbances and affect the certification process.
- You can also plan for future hoods to be added to the system. But make sure future expansion is identified in the building plan, so that the whole building exhaust and supply can accommodate future needs. For example, you can buy a blower for a 4-hood system when you're only planning to install two hoods at first. Then just block off your "future" duct until you acquire the additional hoods.

#### Energy Costs Count in Planning for Fume Hoods

- Minimize the negative air requirement in your lab.
- Validate your fume hood requirements carefully. Get your MEP engineer involved early to plan for the entire lab and building needs.
- Don't undercut your needs. The worst thing you can do is run out of air.
- In the past, fume hoods were specified at 100 Linear Feet per Minute (LFM) at full sash open. Current industry standards are now 100 LFM at 18" sash open.
- Check your local codes and internal EH&S requirements before you install your hoods.

# STEEL CASEWORK

Steel casework is the backbone of your lab.  
Nobody does it better than Hanson.

## Steel Casework Index

	Page
<b>STEEL CABINET DETAILS</b> .....	11
<b>STANDING HEIGHT CABINETS</b> .....	13
• Base Cabinets .....	13
• Corner Base Cabinets .....	17
• Sink Cabinets .....	18
<b>SITTING HEIGHT CABINETS</b> .....	19
• Base Cabinets .....	19
• Corner Base Cabinets .....	23
• Sink Cabinets .....	24
<b>ADA HEIGHT CABINETS</b> .....	25
• Base Cabinets .....	25
• Corner Base Cabinets .....	27
• Sink Cabinets .....	28
<b>SUSPENDED CABINETS</b> .....	29
<b>MOBILE CABINETS</b> .....	30
<b>CHEMICAL STORAGE CABINETS</b> .....	32
• Acid/Corrosive Cabinets .....	32
• Flammable Cabinets.....	35
<b>SPECIALITY CABINETS</b> .....	38
• Equipment Cabinets .....	38
• Vacuum Cabinets.....	39

	Page
<b>CASEWORK ACCESSORIES, FILLERS, APRONS</b> .....	42
• Cabinet Accessories .....	42
• Fillers and Scribes .....	43
• Knee Space Panels .....	44
• Rear Enclosure Panels .....	46
• Drawer Frames, Apron Rails .....	47
• Leg Assemblies and Countertop Support .....	48
• Umbilical Pipe Chases.....	49
<b>WALL CABINETS</b> .....	50
• Wall Cabinet Details .....	50
• 24" Wall Cabinet .....	51
• 30" Wall Cabinet .....	53
• 36" Wall Cabinet .....	55
• 48" Wall Cabinet .....	57
• Wall Cabinet Accessories .....	59
<b>TALL CABINETS</b> .....	61
• Tall Cabinet Details.....	61
• 84" Tall Cabinets.....	62
• Tall Cabinet Accessories.....	67

*\*Laminate and wood may also be available. Contact your HLS Sales representative for more details*



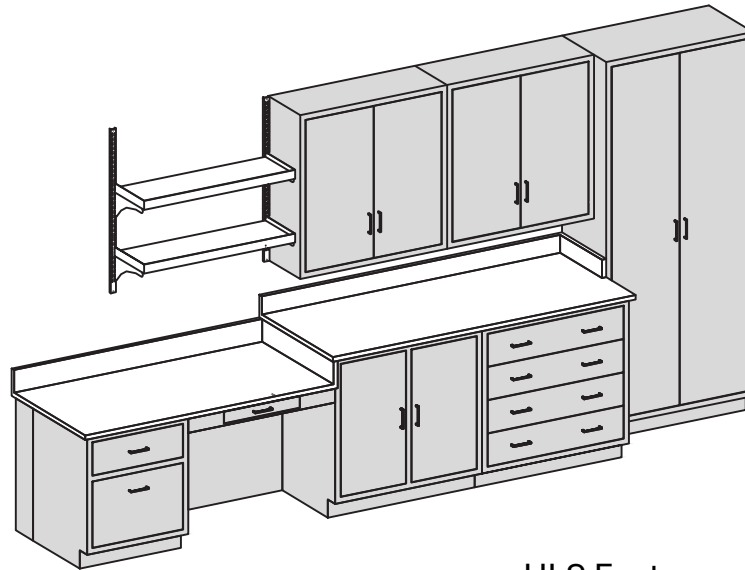

## HLS Features and Benefits

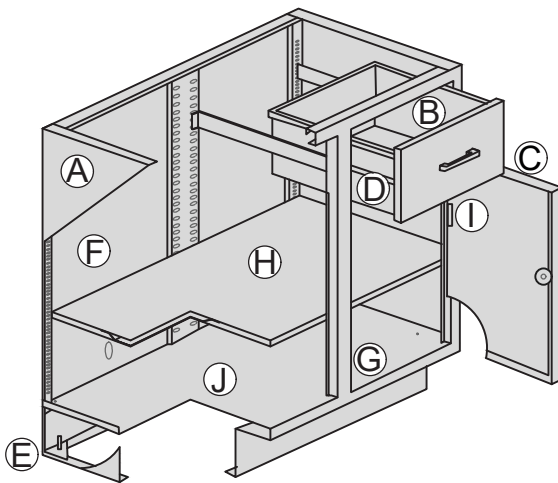

- Ⓐ Cabinet body design accepts multiple arrangements of doors and drawers to permit field changes at any time.
- Ⓑ One piece drawer bodies with coved horizontal corners for easy cleaning.
- Ⓒ 18 ga. double walled drawer and door fronts, with sound deadening full channeled edges.
- Ⓓ Full extension, ball bearing, 100 lb. capacity drawer slides.
- Ⓔ 14 ga. welded gusset plates with hex head leveling bolts at all corners.
- Ⓕ 18 ga. fully removable back panels included in door and open cabinets for access to service piping behind cabinets.
- Ⓖ 20 ga. cabinet bodies with flush seamless welded face. Channel - shaped intermediate uprights prevent cabinet racking and deliver a precise fit of doors and drawers.
- Ⓗ 20 ga. adjustable shelves are included in open and cupboard cabinets.
- Ⓘ Stainless steel 5-knuckle hinges.
- Ⓝ HLS cabinets have electrostatically applied baked on powder coated epoxy paint finish for superior performance.

**THE SCIENCE OF  
LABORATORY  
CONSTRUCTION...**

# STEEL CABINET DETAILS

## General Dimensions

### Hanson Base Cabinets

Hanson cabinets are supplied in a variety of styles, sizes and options to meet your specific applications.

- Standing height base cabinets
- ADA height base cabinets
- Sitting height base cabinets
- Suspended cabinets
- Mobile cabinets
- Specialty cabinets
- Cabinet options and accessories

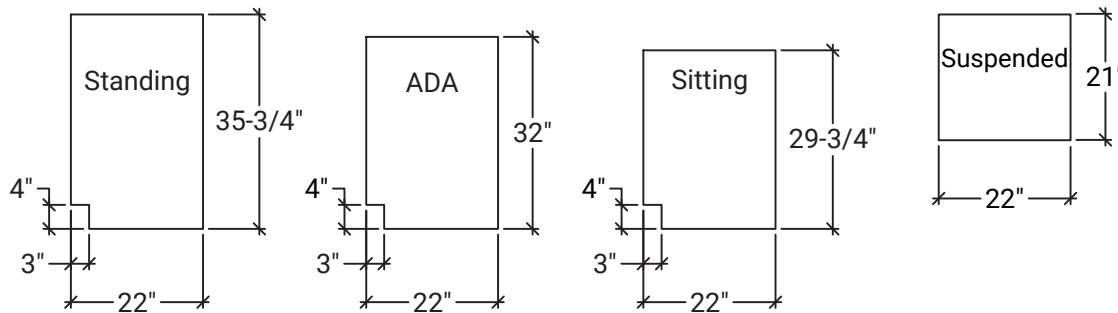
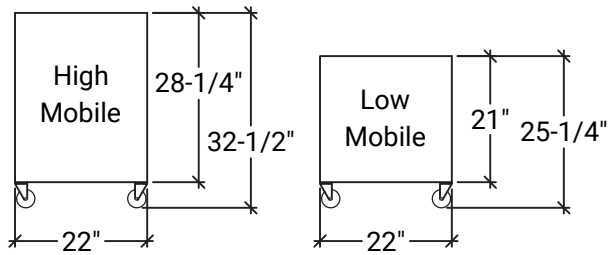

### Drawers

- Full access drawers feature a one piece drawer bodies for easy cleaning
- 18 ga. double walled on drawer body, with sound deadening full channeled edges
- Suspended on full extension, ball bearing, 100 lb. capacity drawer slides

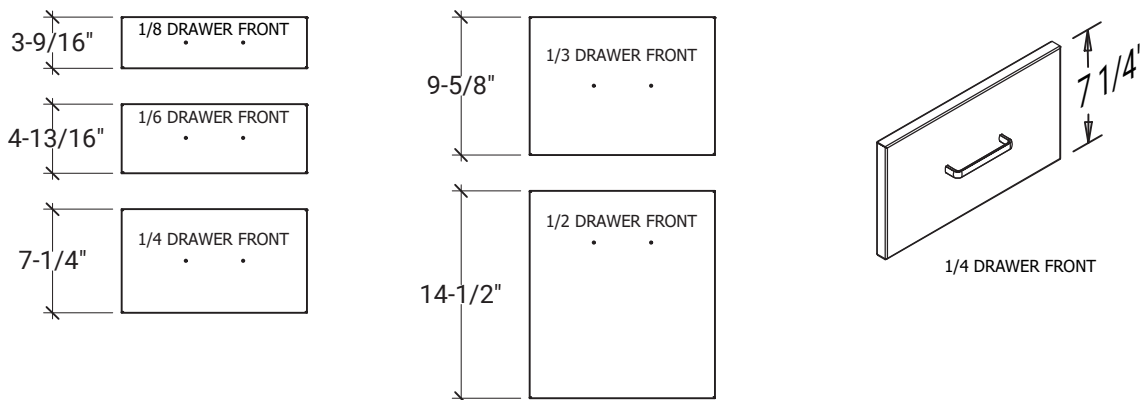

# BASE CABINETS



Standing Height • 35-3/4"

hansonlab.com • 805-498-3121

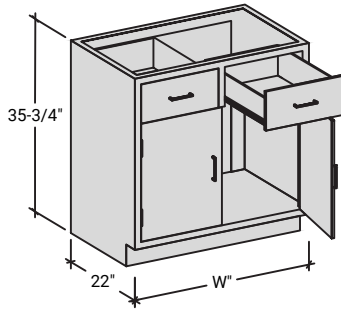

## The HLS Advantages:

- Inset steel - flush face construction
- Standing height cabinets are 35-3/4" high and 22" deep
- Open cabinets have 2 adjustable shelves
- Cabinets with doors include one adjustable shelf
- Open and cabinets with doors have removable back panels
- See end of section for available accessories

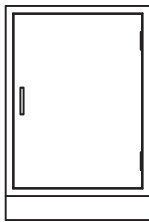

Model	Width
AA15H	15"
AA18H	18-1/8"
AA24H	24-1/8"

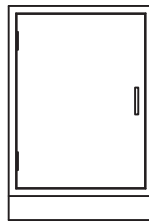

Model	Width
AA15HL	15"
AA18HL	18-1/8"
AA24HL	24-1/8"

L= Left Hinged Door

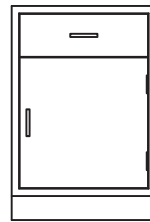

Model	Width
AB15H	15"
AB18H	18-1/8"
AB24H	24-1/8"

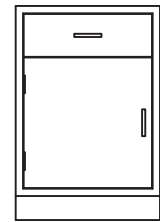

Model	Width
AB15HL	15"
AB18HL	18-1/8"
AB24HL	24-1/8"

L= Left Hinged Door

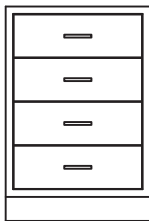

Model	Width
AE15H	15"
AE18H	18-1/8"
AE24H	24-1/8"



Model	Width
AF18H	18-1/8"
AF24H	24-1/8"



Model	Width
AH18H	18-1/8"
AH24H	24-1/8"

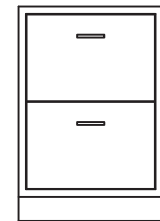

Model	Width
AI18H	18-1/8"
AI24H	24-1/8"

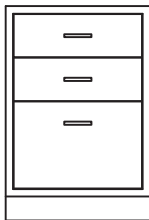

Model	Width
AK18H	18-1/8"
AK24H	24-1/8"

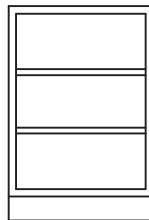

Model	Width
AJ15H	15"
AJ18H	18-1/8"
AJ24H	24-1/8"



# BASE CABINETS

Standing Height • 35-3/4"

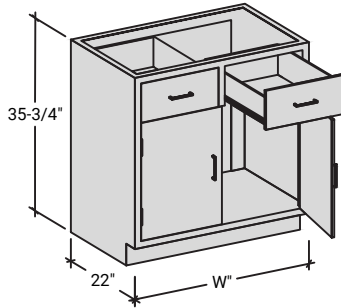

## The HLS Advantages:

- Inset steel - flush face construction
- Standing height cabinets are 35-3/4" high and 22" deep
- Open cabinets have 2 adjustable shelves
- Cabinets with doors include one adjustable shelf
- Open and cabinets with doors have removable back panels
- See end of section for available accessories

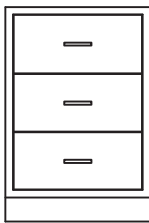

Model	Width
CE18H	18-1/8"
CE24H	24-1/8"

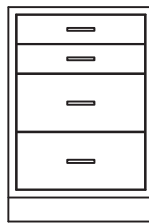

Model	Width
CF18H	18-1/8"
CF24H	24-1/8"

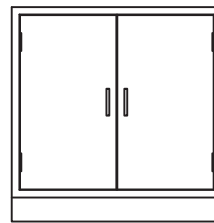

Model	Width
CA30H	30"
CA35H	35"
CA42H	42"
CA47H	47"

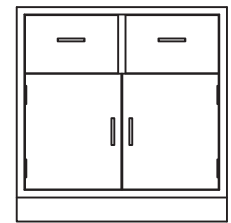

Model	Width
CD30H	30"
CD35H	35"
CD42H	42"
CD47H	47"

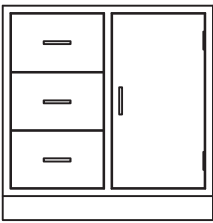

Model	Width
CG30H	30"
CG35H	35"
CG42H	42"
CG47H	47"

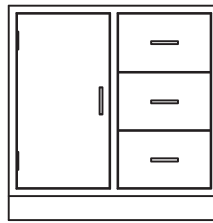

Model	Width
CG30HLC	30"
CG35HLC	35"
CG42HLC	42"
CG47HLC	47"

LC = Left Door

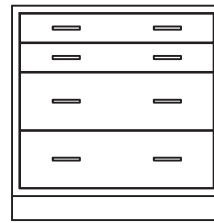

Model	Width
CN30H	30"
CN35H	35"
CN42H	42"
CN47H	47"

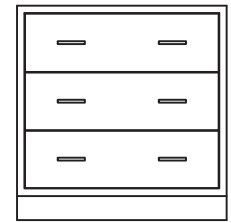

Model	Width
CP30H	30"
CP35H	35"
CP42H	42"
CP47H	47"

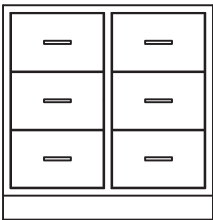

Model	Width
CT30H	30"
CT35H	35"
CT42H	42"
CT47H	47"



# BASE CABINETS



Standing Height • 35-3/4"

hansonlab.com • 805-498-3121

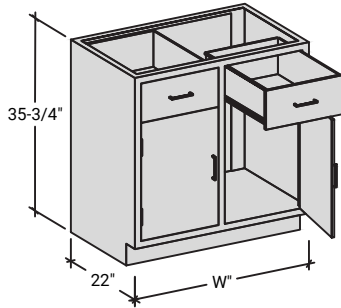

## The HLS Advantages:

- Inset steel - flush face construction
- Standing height cabinets are 35-3/4" high and 22" deep
- Open cabinets have 2 adjustable shelves
- Cabinets with doors include one adjustable shelf
- Open and cabinets with doors have removable back panels
- See end of section for available accessories

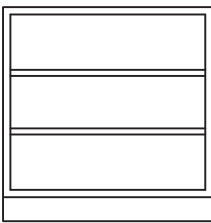

Model	Width
DY30H	30"
DY35H	35"
DY42H	42"
DY47H	47"

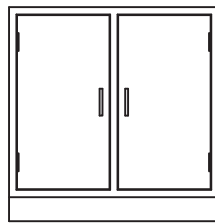

Model	Width
DA30H	30"
DA35H	35"
DA42H	42"
DA47H	47"

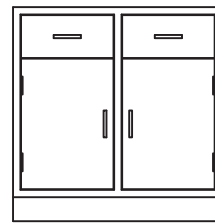

Model	Width
DD30H	30"
DD35H	35"
DD42H	42"
DD47H	47"

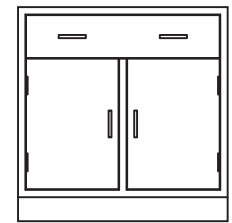

Model	Width
DC30H	30"
DC35H	35"
DC42H	42"
DC47H	47"

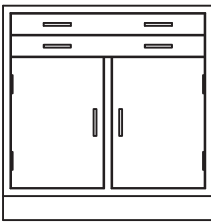

Model	Width
DE30H	30"
DE35H	35"
DE42H	42"
DE47H	47"



Model	Width
DF30H	30"
DF35H	35"
DF42H	42"
DF47H	47"

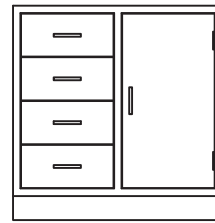

Model	Width
DG30H	30"
DG35H	35"
DG42H	42"
DG47H	47"

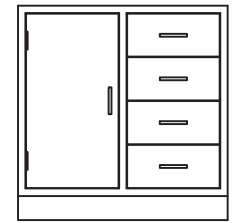

Model	Width
DG30HLC	30"
DG35HLC	35"
DG42HLC	42"
DG47HLC	47"

LC = Left Door



Model	Width
DH30H	30"
DH35H	35"
DH42H	42"
DH47H	47"

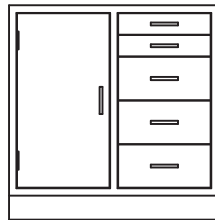

Model	Width
DH30HLC	30"
DH35HLC	35"
DH42HLC	42"
DH47HLC	47"

LC = Left Door

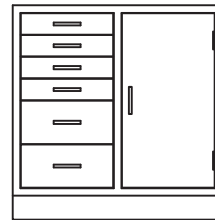

Model	Width
DI30H	30"
DI35H	35"
DI42H	42"
DI47H	47"

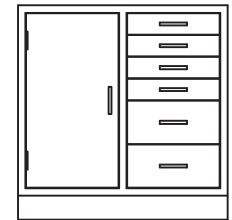

Model	Width
DI30HLC	30"
DI35HLC	35"
DI42HLC	42"
DI47HLC	47"

LC = Left Door

# BASE CABINETS

Standing Height • 35-3/4"

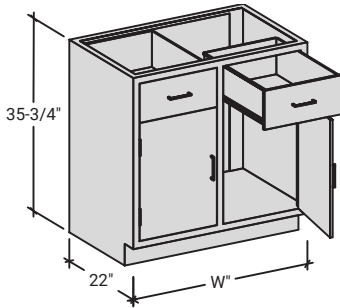

## The HLS Advantages:

- Inset steel - flush face construction
- Standing height cabinets are 35-3/4" high and 22" deep
- Open cabinets have 2 adjustable shelves
- Cabinets with doors include one adjustable shelf
- Open and cabinets with doors have removable back panels
- See end of section for available accessories

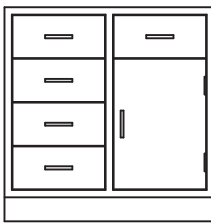

Model	Width
DK30H	30"
DK35H	35"
DK42H	42"
DK47H	47"

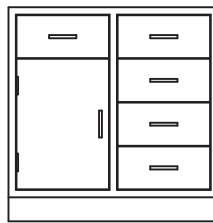

Model	Width
DK30HLC	30"
DK35HLC	35"
DK42HLC	42"
DK47HLC	47"

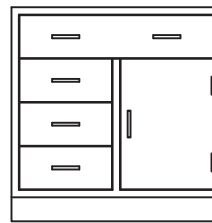

Model	Width
DO30H	30"
DO35H	35"
DO42H	42"
DO47H	47"

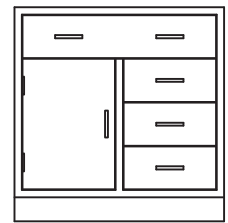

Model	Width
DO30HLC	30"
DO35HLC	35"
DO42HLC	42"
DO47HLC	47"

LC = Left Door

LC = Left Door



Model	Width
DN30H	30"
DN35H	35"
DN42H	42"
DN47H	47"

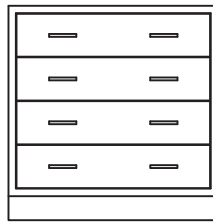

Model	Width
DP30H	30"
DP35H	35"
DP42H	42"
DP47H	47"

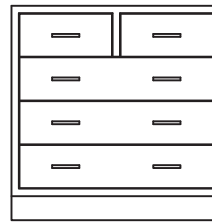

Model	Width
DQ30H	30"
DQ35H	35"
DQ42H	42"
DQ47H	47"



Model	Width
DR30H	30"
DR35H	35"
DR42H	42"
DR47H	47"



Model	Width
DS30H	30"
DS35H	35"
DS42H	42"
DS47H	47"

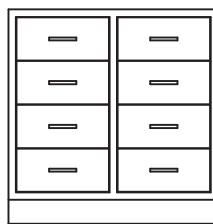

Model	Width
DT30H	30"
DT35H	35"
DT42H	42"
DT47H	47"

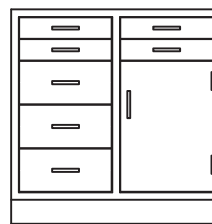

Model	Width
DZ30H	30"
DZ35H	35"
DZ42H	42"
DZ47H	47"



Model	Width
DZ30HLC	30"
DZ35HLC	35"
DZ42HLC	42"
DZ47HLC	47"



LC = Left Door



# CORNER BASE CABINETS



Standing Height • 35-3/4"

[hansonlab.com](http://hansonlab.com) • 805-498-3121

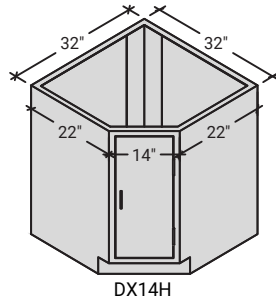
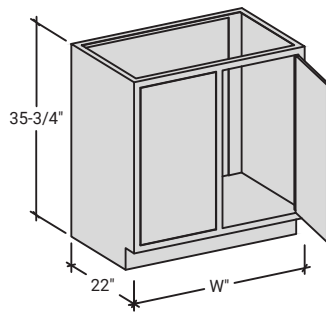

## The HLS Advantages:

- Inset steel - flush face construction
- Standing height cabinets are 35-3/4" high
- DX diagonal corner cabinets do not have shelves
- See end of section for available accessories

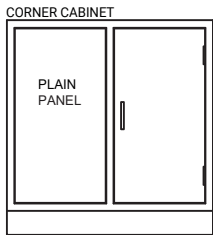

Model	Width
DW30H	30"
DW35H	35"
DW42H	42"
DW47H	47"

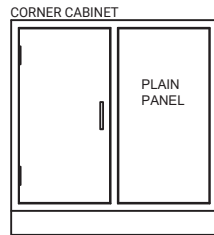

Model	Width
DW30HLC	30"
DW35HLC	35"
DW42HLC	42"
DW47HLC	47"

LC= Left Door

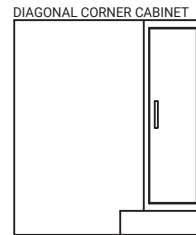

Model	Width
DX14H	32"



# SINK CABINETS

Standing Height • 35-3/4" - Sink

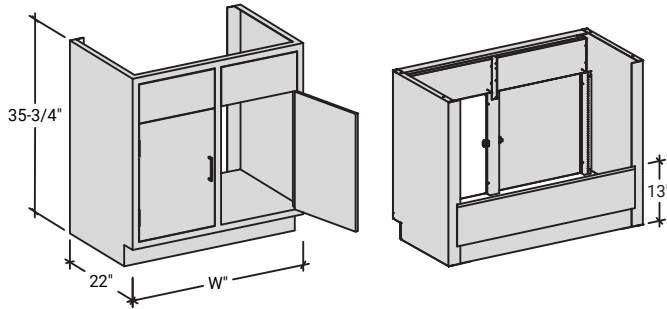

## The HLS Advantages:

- Inset steel - flush face construction
- Standing height cabinets are 35-3/4" high
- Sink cabinets have a lower rear panel
- If a cutout is required at the front toe kick for a foot-controlled fixture application, specify -FCCLP after the sink cabinet model number
- See end of section for available accessories

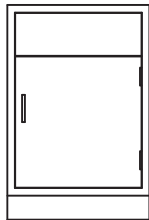

Model	Width
AC18H	18-1/8"
AC24H	24-1/8"

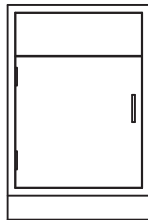

Model	Width
AC18HL	18-1/8"
AC24HL	24-1/8"

L = Left Hinged Door

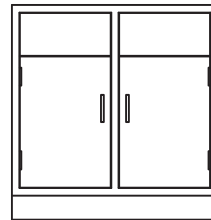

Model	Width
DB30H	30"
DB35H	35"
DB42H	42"
DB47H	47"
DB52H	52"
DB58H	58"

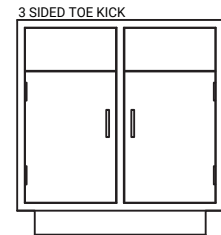

Model	Width
DB47H3S	47"
DB52H3S	52"
DB58H3S	58"

Sitting Height • 29-3/4"

hansonlab.com • 805-498-3121

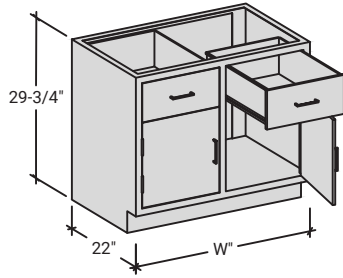

### The HLS Advantages:

- Inset steel - flush face construction
- Sitting height cabinets are 29-3/4" high and 22" deep
- Open cabinets have 2 adjustable shelves
- Cabinets with doors include one adjustable shelf
- Open and cabinets with doors have removable back panels
- See end of section for available accessories

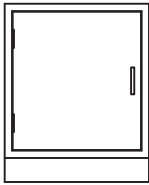

Model	Width
AA15LL	15"
AA18LL	18-1/8"
AA24LL	24-1/8"

L = Left Hinged Door

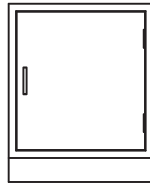

Model	Width
AA15L	15"
AA18L	18-1/8"
AA24L	24-1/8"

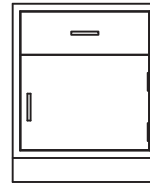

Model	Width
AB15L	15"
AB18L	18-1/8"
AB24L	24-1/8"

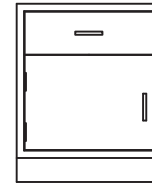

Model	Width
AB15LL	15"
AB18LL	18-1/8"
AB24LL	24-1/8"

L = Left Hinged Door



Model	Width
AD15L	15"
AD18L	18-1/8"
AD24L	24-1/8"



Model	Width
AF18L	18-1/8"
AF24L	24-1/8"



Model	Width
AH18L	18-1/8"
AH24L	24-1/8"



Model	Width
AG18L	18-1/8"
AG24L	24-1/8"

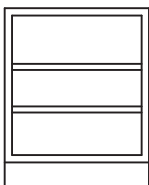

Model	Width
AJ15L	15"
AJ18L	18-1/8"
AJ24L	24-1/8"

# BASE CABINETS

Sitting Height • 29-3/4"

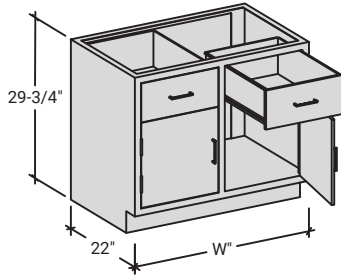

## The HLS Advantages:

- Inset steel - flush face construction
- Sitting height cabinets are 29-3/4" high and 22" deep
- Open cabinets have 2 adjustable shelves
- Cabinets with doors include one adjustable shelf
- Open and cabinets with doors have removable back panels
- See end of section for available accessories

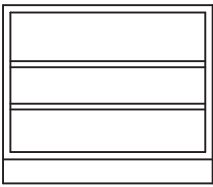

Model	Width
DY30L	30"
DY35L	35"
DY42L	42"
DY47L	47"

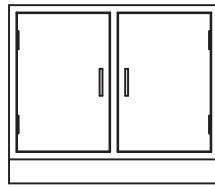

Model	Width
DA30L	30"
DA35L	35"
DA42L	42"
DA47L	47"

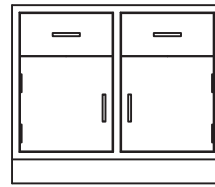

Model	Width
DD30L	30"
DD35L	35"
DD42L	42"
DD47L	47"

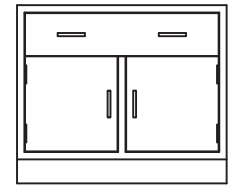

Model	Width
DC30L	30"
DC35L	35"
DC42L	42"
DC47L	47"

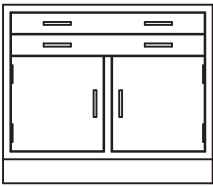

Model	Width
DE30L	30"
DE35L	35"
DE42L	42"
DE47L	47"



Model	Width
DF30L	30"
DF35L	35"
DF42L	42"
DF47L	47"

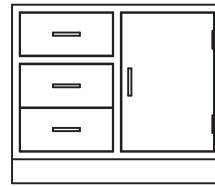

Model	Width
DG30L	30"
DG35L	35"
DG42L	42"
DG47L	47"

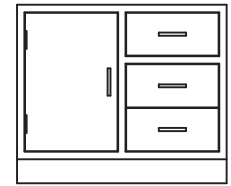

Model	Width
DG30LLC	30"
DG35LLC	35"
DG42LLC	42"
DG47LLC	47"

LC = Left Door

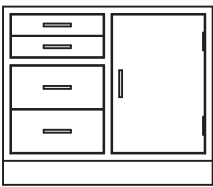

Model	Width
DH30L	30"
DH35L	35"
DH42L	42"
DH47L	47"

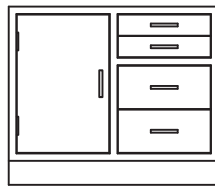

Model	Width
DH30LLC	30"
DH35LLC	35"
DH42LLC	42"
DH47LLC	47"

LC = Left Door

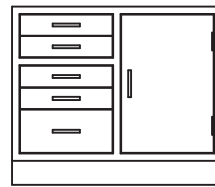

Model	Width
DI30L	30"
DI35L	35"
DI42L	42"
DI47L	47"

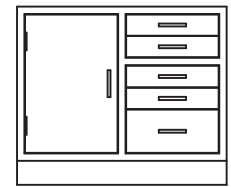

Model	Width
DI30LLC	30"
DI35LLC	35"
DI42LLC	42"
DI47LLC	47"

LC = Left Door

# BASE CABINETS



Sitting Height • 29-3/4"

[hansonlab.com](http://hansonlab.com) • 805-498-3121

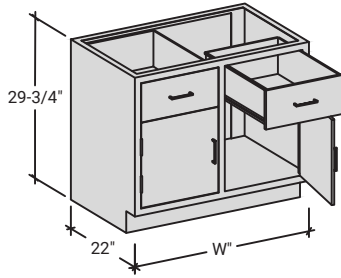

## The HLS Advantages:

- Inset steel - flush face construction
- Sitting height cabinets are 29-3/4" high and 22" deep
- Open cabinets have 2 adjustable shelves
- Cabinets with doors include one adjustable shelf
- Open and cabinets with doors have removable back panels
- See end of section for available accessories

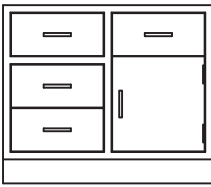

Model	Width
DK30L	30"
DK35L	35"
DK42L	42"
DK47L	47"

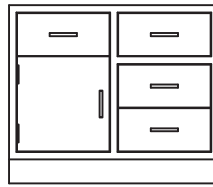

Model	Width
DK30LLC	30"
DK35LLC	35"
DK42LLC	42"
DK47LLC	47"

LC = Left Door

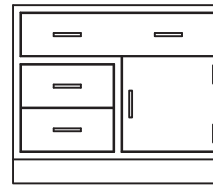

Model	Width
D030L	30"
D035L	35"
D042L	42"
D047L	47"

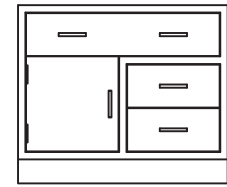

Model	Width
D030LLC	30"
D035LLC	35"
D042LLC	42"
D047LLC	47"

LC = Left Door

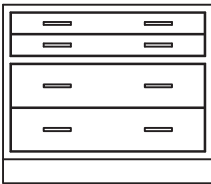

Model	Width
DN30L	30"
DN35L	35"
DN42L	42"
DN47L	47"

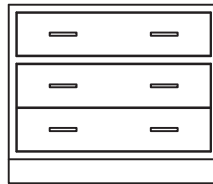

Model	Width
DP30L	30"
DP35L	35"
DP42L	42"
DP47L	47"

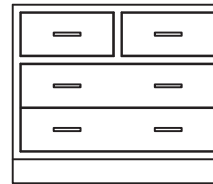

Model	Width
DQ30L	30"
DQ35L	35"
DQ42L	42"
DQ47L	47"

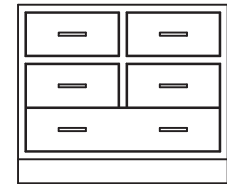

Model	Width
DR30L	30"
DR35L	35"
DR42L	42"
DR47L	47"

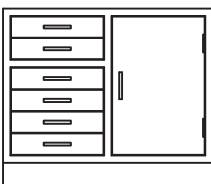

Model	Width
DJ30L	30"
DJ35L	35"
DJ42L	42"
DJ47L	47"

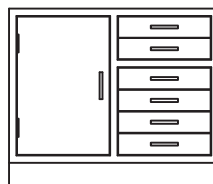

Model	Width
DJ30LLC	30"
DJ35LLC	35"
DJ42LLC	42"
DJ47LLC	47"

LC = Left Door



Model	Width
DZ30L	30"
DZ35L	35"
DZ42L	42"
DZ47L	47"

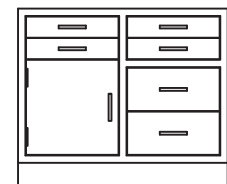

Model	Width
DZ30LLC	30"
DZ35LLC	35"
DZ42LLC	42"
DZ47LLC	47"

LC = Left Door

# BASE CABINETS

Sitting Height • 29-3/4"

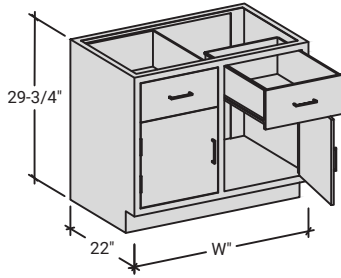

## The HLS Advantages:

- Inset steel - flush face construction
- Sitting height cabinets are 29-3/4" high and 22" deep
- Open cabinets have 2 adjustable shelves
- Cabinets with doors include one adjustable shelf
- Open and cabinets with doors have removable back panels
- See end of section for available accessories

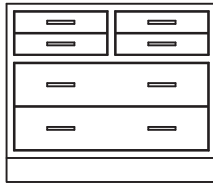

Model	Width
DS30L	30"
DS35L	35"
DS42L	42"
DS47L	47"

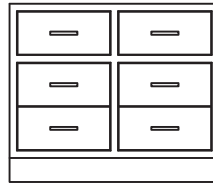

Model	Width
DT30L	30"
DT35L	35"
DT42L	42"
DT47L	47"

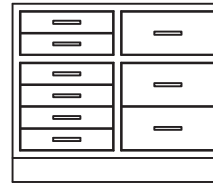

Model	Width
DV30L	30"
DV35L	35"
DV42L	42"
DV47L	47"

# CORNER BASE CABINETS



Sitting Height • 29-3/4"

[hansonlab.com](http://hansonlab.com) • 805-498-3121

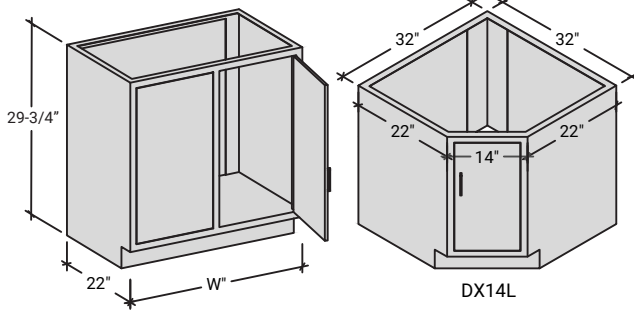

## The HLS Advantages:

- Inset steel - flush face construction
- Sitting height cabinets are 29-3/4" high
- DX diagonal corner cabinets do not have shelves
- See end of section for available accessories

CORNER CABINET

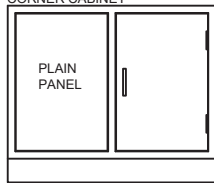

Model	Width
DW30L	30"
DW35L	35"
DW42L	42"
DW47L	47"

CORNER CABINET

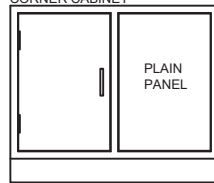

Model	Width
DW30LLC	30"
DW35LLC	35"
DW42LLC	42"
DW47LLC	47"

LC= Left Door

DIAGONAL CORNER CABINET

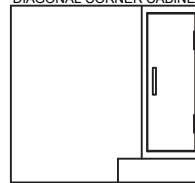

Model	Width
DX14L	32"

# SINK CABINETS

Sitting Height • 29-3/4"

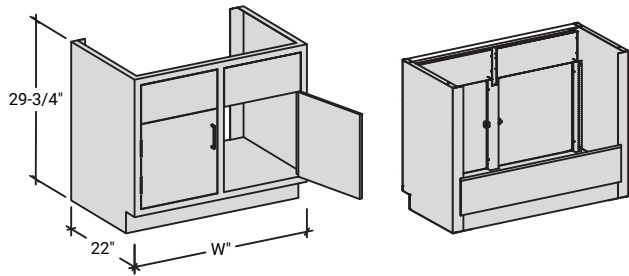

## The HLS Advantages:

- Inset steel - flush face construction
- Sitting height cabinets are 29-3/4" high
- Sink cabinets have a lower rear panel
- If a cutout is required at the front toe kick for a foot-controlled fixture application, specify -FCCLP after the sink cabinet model number
- See end of section for available accessories

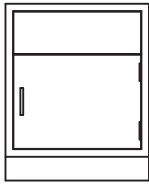

Model	Width
AC18L	18-1/8"
AC24L	24-1/8"

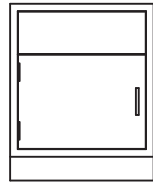

Model	Width
AC18LL	18-1/8"
AC24LL	24-1/8"

L = Left Hinged Door

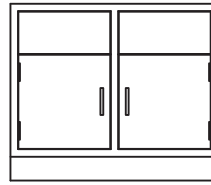

Model	Width
DB30L	30"
DB35L	35"
DB42L	42"
DB47L	47"
DB52L	52"
DB58L	58"

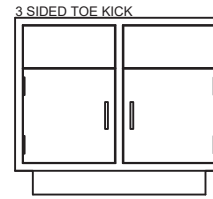

Model	Width
DB47L3S	47"
DB52L3S	52"
DB58L3S	58"



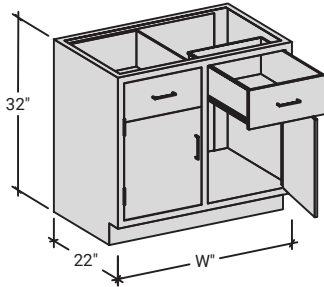

### The HLS Advantages:

- Inset steel - flush face construction
- ADA height cabinets are 32" high and 22" deep
- Open cabinets have 2 adjustable shelves
- Cabinets with doors include one adjustable shelf
- Open and cabinets with doors have removable back panels
- See end of section for available accessories

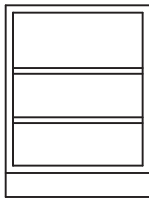

Model	Width
AJ15ADA	15"
AJ18ADA	18-1/8"
AJ24ADA	24-1/8"

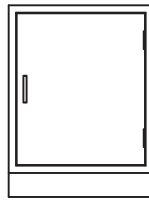

Model	Width
AA15ADA	15"
AA18ADA	18-1/8"
AA24ADA	24-1/8"

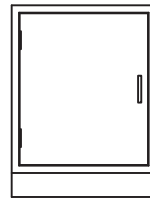

Model	Width
AA15ADAL	15"
AA18ADAL	18-1/8"
AA24ADAL	24-1/8"

L = Left Hinged Door

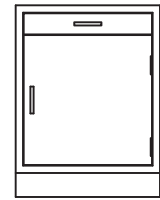

Model	Width
AB15ADA	15"
AB18ADA	18-1/8"
AB24ADA	24-1/8"

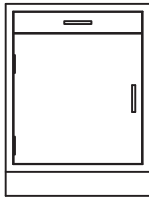

Model	Width
AB15ADAL	15"
AB18ADAL	18-1/8"
AB24ADAL	24-1/8"

L = Left Hinged Door



Model	Width
AF15ADA	15"
AF18ADA	18-1/8"
AF24ADA	24-1/8"



Model	Width
AG18ADA	18-1/8"
AG24ADA	24-1/8"



# BASE CABINETS

ADA Height • 32"

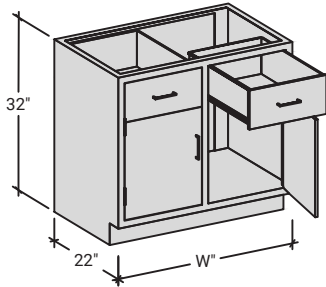

## The HLS Advantages:

- Inset steel - flush face construction
- ADA height cabinets are 32" high and 22" deep
- Open cabinets have 2 adjustable shelves
- Open and cabinets with doors have removable back panels
- See end of section for available accessories

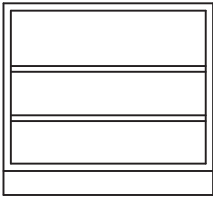

Model	Width
DY30ADA	30"
DY35ADA	35"
DY42ADA	42"
DY47ADA	47"

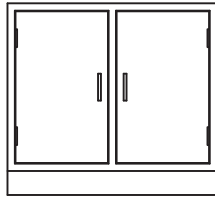

Model	Width
DA30ADA	30"
DA35ADA	35"
DA42ADA	42"
DA47ADA	47"

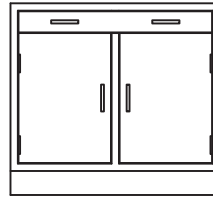

Model	Width
DC30ADA	30"
DC35ADA	35"
DC42ADA	42"
DC47ADA	47"

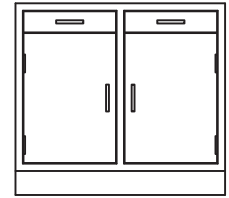

Model	Width
DD30ADA	30"
DD35ADA	35"
DD42ADA	42"
DD47ADA	47"

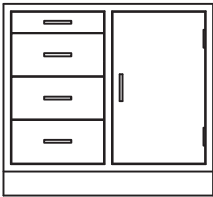

Model	Width
DG30ADA	30"
DG35ADA	35"
DG42ADA	42"
DG47ADA	47"

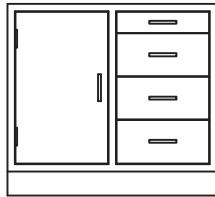

Model	Width
DG30ADALC	30"
DG35ADALC	35"
DG42ADALC	42"
DG47ADALC	47"

LC = Left Door

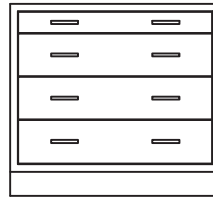

Model	Width
DP30ADA	30"
DP35ADA	35"
DP42ADA	42"
DP47ADA	47"



Model	Width
DR30ADA	30"
DR35ADA	35"
DR42ADA	42"
DR47ADA	47"

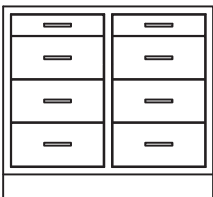

Model	Width
DT30ADA	30"
DT35ADA	35"
DT42ADA	42"
DT47ADA	47"

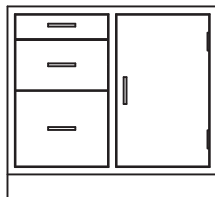

Model	Width
DU30ADA	30"
DU35ADA	35"
DU42ADA	42"
DU47ADA	47"

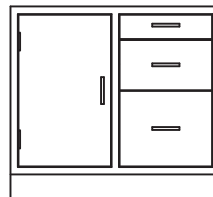

Model	Width
DU30ADALC	30"
DU35ADALC	35"
DU42ADALC	42"
DU47ADALC	47"

LC = Left Door

# CORNER BASE CABINETS



ADA Height • 32"

[hansonlab.com](http://hansonlab.com) • 805-498-3121

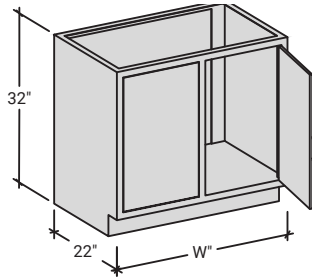

## The HLS Advantages:

- Inset steel - flush face construction
- ADA height cabinets are 32" high
- Corner cabinets have one adjustable shelf

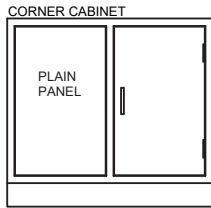

Model	Width
DW30ADA	30"
DW35ADA	35"
DW42ADA	42"
DW47ADA	47"

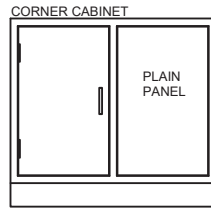

Model	Width
DW30ADALC	30"
DW35ADALC	35"
DW42ADALC	42"
DW47ADALC	47"

LC = Left Door

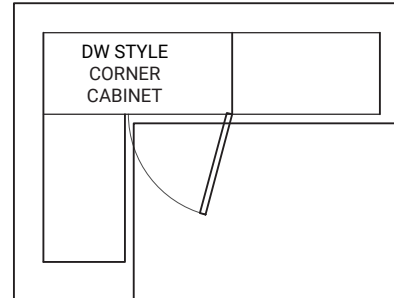

# SINK CABINETS

ADA Height • 32"

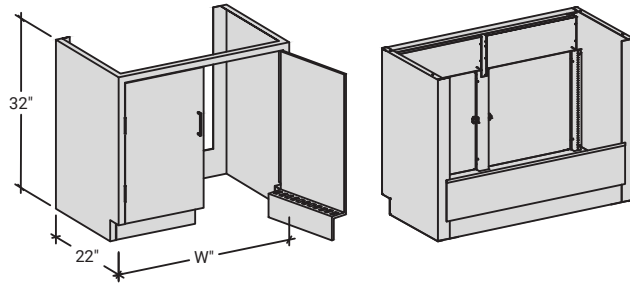

## The HLS Advantages:

- Inset steel - flush face construction
- ADA height cabinets are 32" high
- Sink cabinets without a bottom floor have a vented integral toe-kick for wheelchair accessibility
- Sink cabinet style with floor are not wheelchair accessible
- Sink cabinets have a lower rear panel, no shelves

WITHOUT FLOOR  
WHEELCHAIR ACCESSIBLE

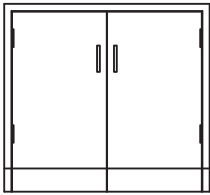

Model	Width
DB35ADA	35"
DB42ADA	42"
DB47ADA	47"
DB52ADA	52"
DB58ADA	58"

WITH FLOOR  
NON WHEELCHAIR ACCESSIBLE

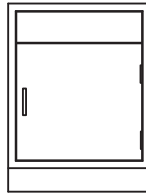

Model	Width
AC18ADAF	18-1/8"
AC24ADAF	24-1/8"

F = Floor

WITH FLOOR  
NON WHEELCHAIR ACCESSIBLE

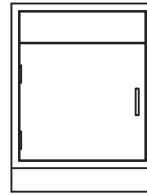

Model	Width
AC18ADALF	18-1/8"
AC24ADALF	24-1/8"

L = Left Hinged Door  
F = Floor

WITH FLOOR  
NON WHEELCHAIR ACCESSIBLE

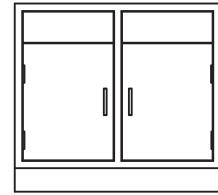

Model	Width
DB30ADAF	30"
DB35ADAF	35"
DB42ADAF	42"
DB47ADAF	47"
DB52ADAF	52"
DB58ADAF	58"

F = Floor

## The HLS Advantages

- Inset steel - flush face construction
- For use with HLS Agility Adaptable, M-Series workstations & HDW tables\*
- Suspended cabinets are 21" high and 22" deep
- Open cabinets and cabinets with doors have one adjustable shelf
- Cabinets can be removed, relocated, or moved to any location on the table chosen
- Suspended cabinets have finished backs and include cabinet attachment brackets

\*specify suspended cabinet option when ordering workstation / table

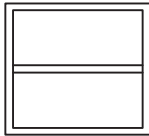
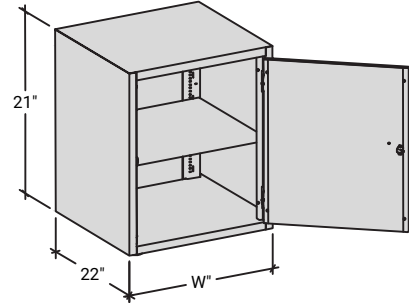

Model	Width
AJ15U	15"
AJ18U	18-1/8"
AJ24U	24-1/8"

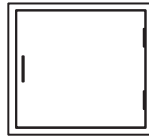

Model	Width
AA15U	15"
AA18U	18-1/8"
AA24U	24-1/8"

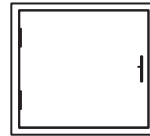

Model	Width
AA15UL	15"
AA18UL	18-1/8"
AA24UL	24-1/8"

L = Left Hinged Door

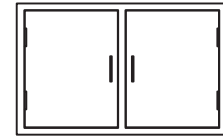

Model	Width
DA30U	30"
DA35U	35"
DA42U	42"

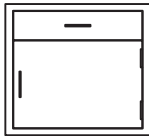

Model	Width
AB15U	15"
AB18U	18-1/8"
AB24U	24-1/8"

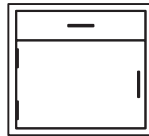

Model	Width
AB15UL	15"
AB18UL	18-1/8"
AB24UL	24-1/8"

L = Left Hinged Door

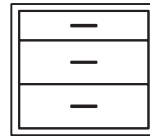

Model	Width
AF18U	18-1/8"
AF24U	24-1/8"

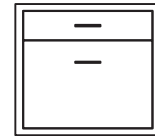

Model	Width
AG18U	18-1/8"
AG24U	24-1/8"

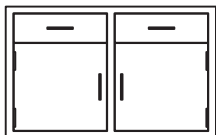

Model	Width
DD30U	30"
DD35U	35"
DD42U	42"

# MOBILE CABINETS

Standard Height • 32 1/2"

## The HLS Advantages

- Inset steel - flush face construction
- Painted steel top and finished backs are standard
- Mobile height cabinets are 32-1/2" high and 22" deep
- Open cabinets have 2 adjustable shelves
- Cabinets with doors have one adjustable shelf
- 3" dia. wheels on 4-1/4" high casters (front casters swivel w/ brake; rear casters fixed, no brake)
- Optional counter tops available - specify material type and thickness (add thickness to mobile cabinet height)

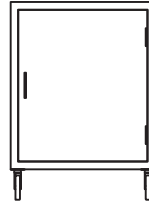

Model	Width
AA15HM	15"
AA18HM	18-1/8"
AA24HM	24-1/8"

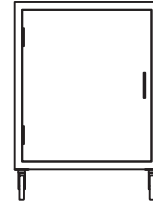

Model	Width
AA15HML	15"
AA18HML	18-1/8"
AA24HML	24-1/8"

L = Left Hinged Door

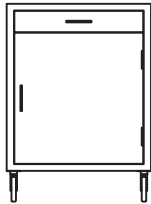

Model	Width
AB15HM	15"
AB18HM	18-1/8"
AB24HM	24-1/8"

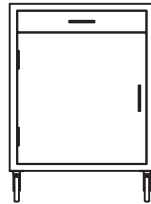

Model	Width
AB15HML	15"
AB18HML	18-1/8"
AB24HML	24-1/8"

L = Left Hinged Door



Model	Width
AF15HM	15"
AF18HM	18-1/8"
AF24HM	24-1/8"

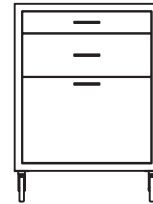

Model	Width
AG18HM	18"
AG24HM	24-1/8"

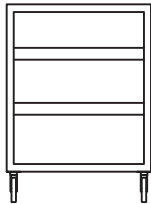

Model	Width
AJ15HM	15"
AJ18HM	18-1/8"
AJ24HM	24-1/8"

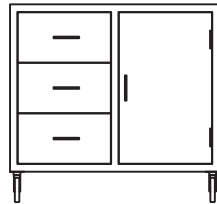

Model	Width
CG30HM	30"
CG35HM	35"
CG42HM	42"
CG47HM	47"

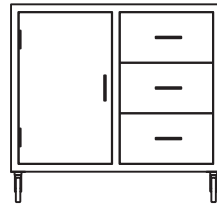

Model	Width
CG30HMLC	30"
CG35HMLC	35"
CG42HMLC	42"
CG47HMLC	47"

LC = Left Door

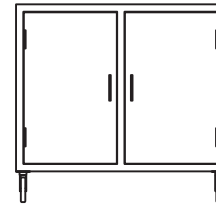

Model	Width
DA30HM	30"
DA35HM	35"
DA42HM	42"
DA47HM	47"

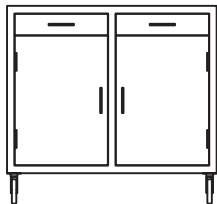

Model	Width
DD30HM	30"
DD35HM	35"
DD42HM	42"
DD47HM	47"

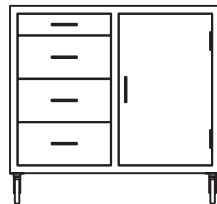

Model	Width
DG30HM	30"
DG35HM	35"
DG42HM	42"
DG47HM	47"

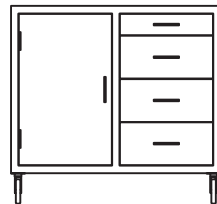

Model	Width
DG30HMLC	30"
DG35HMLC	35"
DG42HMLC	42"
DG47HMLC	47"

LC = Left Door

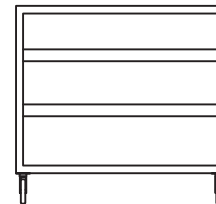

Model	Width
DY30HM	30"
DY35HM	35"
DY42HM	42"
DY47HM	47"

## The HLS Advantages

- Inset steel - flush face construction
- Painted steel top and finished backs are standard
- Mobile height cabinets are 25-1/4" high and 22" deep
- Open cabinets have 2 adjustable shelves
- Cabinets with doors have one adjustable shelf
- 3" dia. wheels on 4-1/4" high casters (front casters swivel w/ brake; rear casters fixed, no brake)
- Optional counter tops available - specify material type and thickness (add thickness to mobile cabinet height)

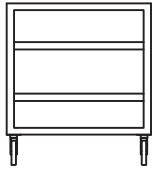
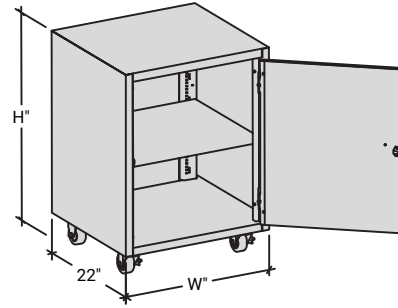

Model	Width
AJ15LM	15"
AJ18LM	18-1/8"
AJ24LM	24-1/8"

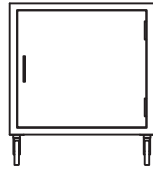

Model	Width
AA15LM	15"
AA18LM	18-1/8"
AA24LM	24-1/8"

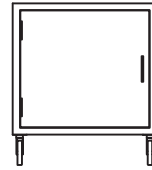

Model	Width
AA15LML	15"
AA18LML	18-1/8"
AA24LML	24-1/8"

L = Left Hinged Door

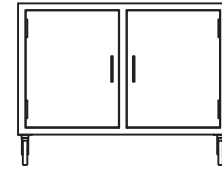

Model	Width
DA30LM	30"
DA35LM	35"
DA42LM	42"

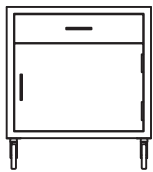

Model	Width
AB15LM	15"
AB18LM	18-1/8"
AB24LM	24-1/8"

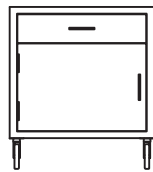

Model	Width
AB15LML	15"
AB18LML	18-1/8"
AB24LML	24-1/8"

L = Left Hinged Door



Model	Width
AF18LM	18-1/8"
AF24LM	24-1/8"

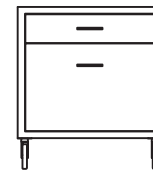

Model	Width
AG18LM	18-1/8"
AG24LM	24-1/8"

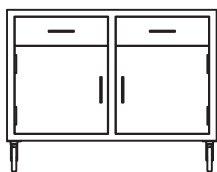

Model	Width
DD30LM	30"
DD35LM	35"
DD42LM	42"

# CHEMICAL STORAGE CABINETS

Standing Height • 35-3/4"

## Acid / Base / Corrosive Storage Cabinets

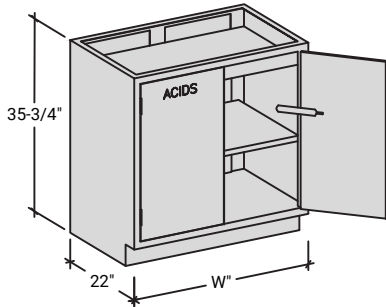

- Designed for under counter and under fume hood applications, for storage of corrosive materials
- Pneumatic self-closing door - doors have a 165°F fusible link that automatically closes the doors in case of a fire
- 3 point locking door mechanism with keyed lock
- Includes one adjustable shelf
- Two vent holes are provided in the back of cabinet for use with an optional VKACID vent kit
- Lined with corrosive resistant liner board
- Each exterior door face includes 9" x 2-1/4" adhesive label 'ACID' - located as shown
- Cabinet also available with 'BASE' label. Use BSB part number prefix in place of ASB

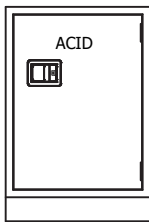

Model	Width
ASB18H	18"
ASB23H	23"
ASB24H	24"

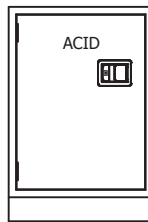

Model	Width
ASB18HL	18"
ASB23HL	23"
ASB24HL	24"

L = Left Hinged Door

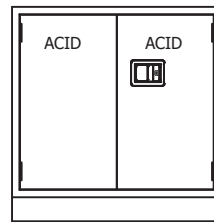

Model	Width
ASB30H	30"
ASB35H	35"
ASB47H	47"

Model	Capacity
ASB18H	10 Gal.
ASB23H	12 Gal.
ASB24H	12 Gal.
ASB30H	16 Gal.
ASB35H	18 Gal.
ASB47H	27 Gal.

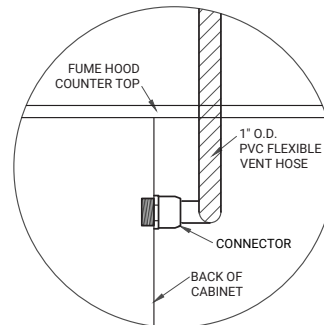

## Acid / Corrosive Cabinet Vent Kit

- For connection from acid cabinet to fume hood
- Includes an 12' long, 1" diameter O.D. PVC flexible hose
- A connection is provided for attachment to the back of the cabinet

Note - these kits may be included with cabinet assemblies listed above

Model	Hose Length
VKACID	12'
VKACID-VAV	25'



Standing Height • 35-3/4"

hansonlab.com • 805-498-3121

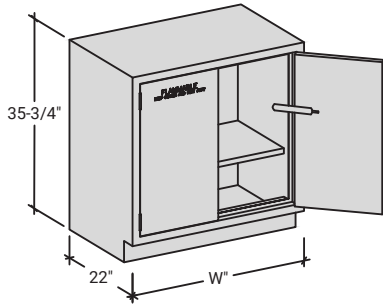

## Flammable Storage Cabinets

- Use under counters, under fume hoods or in stand-alone applications
- Double-wall 18 ga. construction w / 1.5" air space
- Pneumatic self-closing door - doors have a 165°F fusible link that automatically closes the door in case of a fire
- 3 point locking door mechanism with keyed lock
- Chemical-resistant interior and exterior finish
- Includes one adjustable shelf
- 18 ga., 2" sill at bottom to retain spills
- Two spark arrester vent holes are provided in the back of cabinet for use with optional VKFLAM vent kits
- A removable panel is provided in the back of the cabinet for access to plumbing
- Each exterior door face includes 9" x 2-1/4" adhesive label 'FLAMMABLE' - located as shown

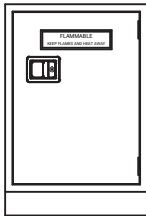

Model	Width
FSB18H	18"
FSB24H	24"

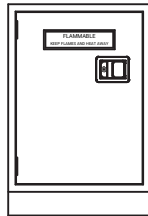

Model	Width
FSB18HL	18"
FSB24HL	24"

L = Left Hinged Door

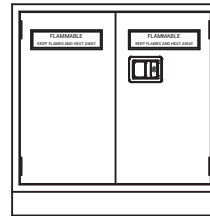

Model	Width
FSB30H	30"
FSB35H	35"
FSB47H	47"

Model	Capacity
FSB18H	10 Gal.
FSB24H	12 Gal.
FSB30H	16 Gal.
FSB35H	18 Gal.
FSB47H	27 Gal.

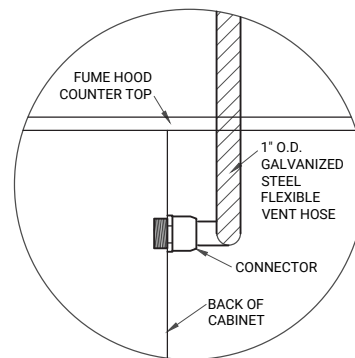

## Flammable Cabinet Vent Kit (optional)

- For vent connection from flammable cabinet
- Includes a 12' long, 1" diameter O.D. galvanized steel flexible hose
- Connection by others
- A connection is provided for attachment to the back of the cabinet

Model	Hose Length
VKFLAM	12'
VKFLAM-VAV	25'

# CHEMICAL STORAGE CABINETS

Sitting Height • 29-3/4"

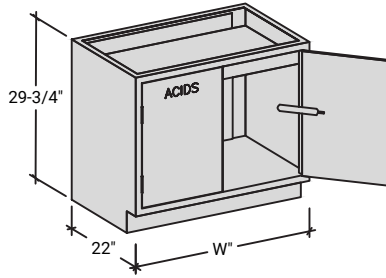

## Acid / Base / Corrosive Storage Cabinets

- Designed for under counter and under fume hood applications, for storage of corrosive materials
- Pneumatic self-closing door - doors have a 165°F fusible link that automatically closes the doors in case of a fire
- 3 point locking door mechanism with keyed lock
- Includes one adjustable shelf
- Two vent holes are provided in the back of cabinet for use with optional VKACID vent kit
- Lined with corrosive resistant liner board
- Each exterior door face includes 9" x 2-1/4" adhesive label 'ACID' - located as shown
- Cabinet also available with 'BASE' label. Use BSB part number prefix in place of ASB

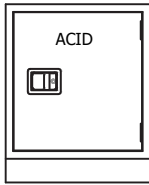

Model	Width
ASB18L	18"
ASB23L	23"
ASB24L	24"

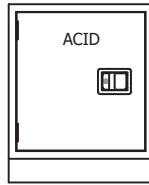

Model	Width
ASB18LL	18"
ASB23LL	23"
ASB24LL	24"

L = Left Hinged Door

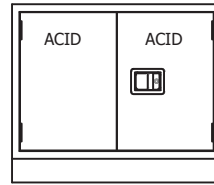

Model	Width
ASB30L	30"
ASB35L	35"
ASB47L	47"

Model	Capacity
ASB18L	8 Gal.
ASB23L	10 Gal.
ASB24L	10 Gal.
ASB30L	12 Gal.
ASB35L	16 Gal.
ASB47L	25 Gal.

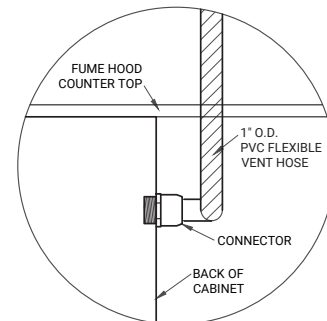

## Acid / Corrosive Cabinet Vent Kit

- For connection from acid cabinet to fume hood
- Includes a 12' long, 1" diameter O.D. PVC flexible hose
- A connection is provided for attachment to the back of cabinet

Model	Hose Length
VKACID	12'
VKACIDVAV	25'

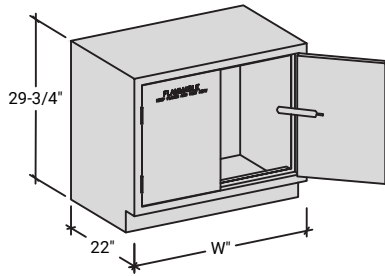

## Flammable Storage Cabinets

- Use under counters, under fume hoods or in stand-alone applications
- Double-wall 18 ga. construction w / 1.5" air space
- Pneumatic self-closing door - doors have a 165°F fusible link that automatically closes the door in case of a fire
- 3 point locking door mechanism with keyed lock
- Chemical-resistant interior and exterior finish
- Includes one adjustable shelf
- 18 ga., 2" sill at bottom to retain spills
- Two spark arrester vent holes are provided in the back of cabinet for use with optional VKFLAM vent kits
- A removable panel is provided in the back of the cabinet for access to plumbing
- Each exterior door face includes 9" x 2-1/4" adhesive label 'FLAMMABLE' - located as shown

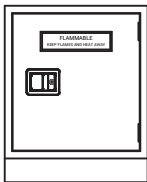

Model	Width
FSB18L	18"
FSB24L	24"



Model	Width
FSB18LL	18"
FSB24LL	24"

L = Left Hinged Door

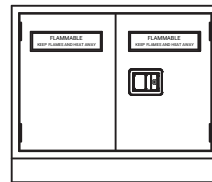

Model	Width
FSB30L	30"
FSB35L	35"
FSB47L	47"

Model	Capacity
FSB18L	8 Gal.
FSB24L	10 Gal.
FSB30L	12 Gal.
FSB35L	16 Gal.
FSB47L	25 Gal.

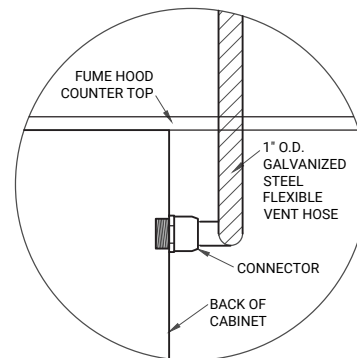

## Flammable Cabinet Vent Kit (optional)

- For vent connection from flammable cabinet
- Includes a 12' long, 1" diameter I.D. galvanized steel flexible hose
- Connection by others
- A connection is provided for attachment to the back of cabinet

Model	Hose Length
VKFLAM	12'
VKFLAM-VAV	25'

# CHEMICAL STORAGE CABINETS

ADA Height • 32"

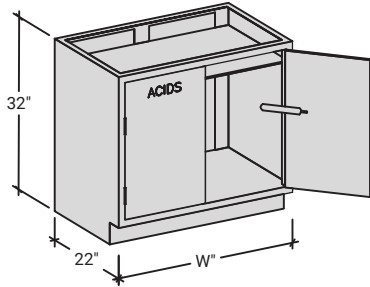

## Acid / Base / Corrosive Storage Cabinets

- Designed for under counter and under fume hood applications, for storage of corrosive materials
- Pneumatic self-closing door - doors have a 165°F fusible link that automatically closes the doors in case of a fire
- 3 point locking door mechanism with keyed lock
- Includes one adjustable shelf
- Two vent holes are provided in the back of cabinet for use with optional VKACID vent kit
- Lined with corrosive resistant liner board
- Each exterior door face includes 9" x 2-1/4" adhesive label 'ACID' - located as shown
- Cabinet also available with 'BASE' label. Use BSB part number prefix in place of ASB

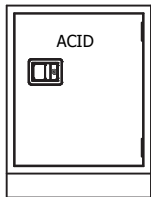

Model	Width
ASB18ADA	18"
ASB23ADA	23"
ASB24ADA	24"

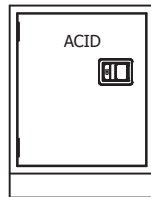

Model	Width
ASB18ADAL	18"
ASB23ADAL	23"
ASB24ADAL	24"

L = Left Hinged Door

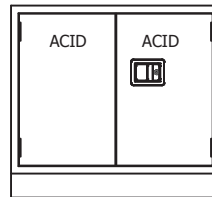

Model	Width
ASB30ADA	30"
ASB35ADA	35"
ASB47ADA	47"

Model	Capacity
ASB18ADA	8 Gal.
ASB23ADA	10 Gal.
ASB24ADA	10 Gal.
ASB30ADA	12 Gal.
ASB35ADA	16 Gal.
ASB47ADA	25 Gal.

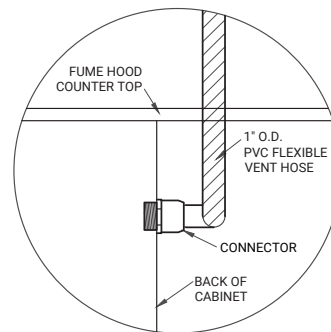

## Acid / Corrosive Cabinet Vent Kit

- For connection from acid cabinet to fume hood
- Includes a 12' long, 1" diameter O.D. PVC flexible hose
- A connection is provided for attachment to the back of cabinet

Model	Hose Length
VKACID	12'
VKACID-VAV	25'

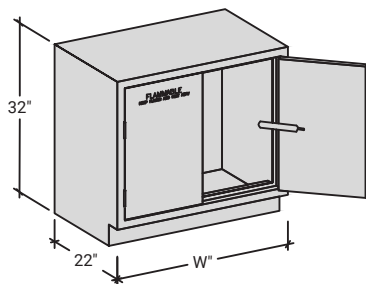

## Flammable Storage Cabinets

- Use under counters, under fume hoods or in stand-alone applications
- Double-wall 18 ga. construction w / 1.5" air space
- Pneumatic self-closing door - doors have a 165°F fusible link that automatically closes the door in case of a fire
- 3 point locking door mechanism with keyed lock
- Chemical-resistant interior and exterior finish
- Includes one adjustable shelf
- 18 ga., 2" sill at bottom to retain spills
- Two spark arrester vent holes are provided in the back of cabinet for use with optional VKFLAM vent kits
- A removable panel is provided in the back of the cabinet for access to plumbing
- Each exterior door face includes 9" x 2-1/4" adhesive label 'FLAMMABLE' - located as shown

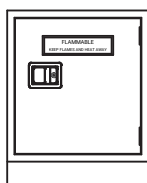

Model	Width
FSB18ADA	18"
FSB24ADA	24"

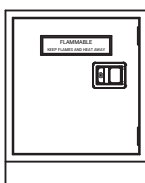

Model	Width
FSB18ADAL	18"
FSB24ADAL	24"

L = Left Hinged Door

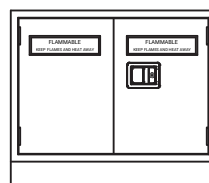

Model	Width
FSB30ADA	30"
FSB35ADA	35"
FSB47ADA	47"

Model	Capacity
FSB18ADA	8 Gal.
FSB24ADA	10 Gal.
FSB30ADA	12 Gal.
FSB35ADA	16 Gal.
FSB47ADA	25 Gal.

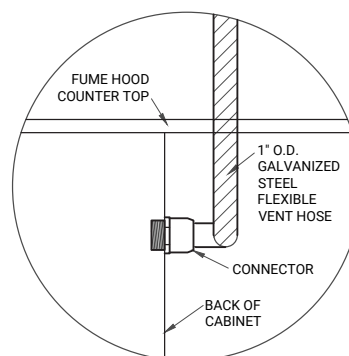

## Flammable Cabinet Vent Kit (optional)

- For vent connection from flammable cabinet
- Includes a 12' long, 1" diameter I.D. galvanized steel flexible hose
- Connection by others
- A connection is provided for attachment to the back of cabinet

Model	Hose Length
VKFLAM	12'
VKFLAM-VAV	25'

# SPECIALTY CABINETS

Standing Height • 35-3/4"

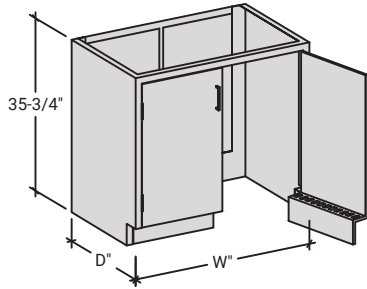

## Equipment Cabinet

- Used for large or roll-in equipment
- Cabinet has an integral vented toe kick without a floor
- Full height back with removable back panel
- Manufactured in 22" and 28" deep cabinets

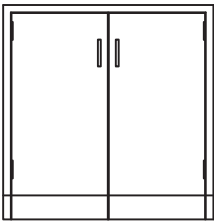

Model	Depth	Width
CU47HA	22"	47"
CU47HB	28"	47"
CU52HA	22"	52"
CU52HB	28"	52"
CU58HA	22"	58"
CU58HB	28"	58"

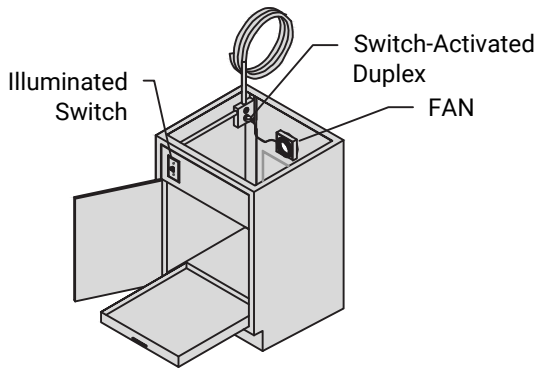

## Vacuum Pump Cabinets

- Models with the suffix "F" come with a floor and pull out bottom shelf
- Designed with pre-wired electrical package, illuminated light switch, interior duplex receptacle, fan, and vented toekick (35", 42", and 47" wide cabinets have 1 electrical package provided with 2 fans)
- One 15ft. electrical conduit whip is provided with each cabinet
- Sound deadening interior insulation
- A vent hole and removable access panel are provided in the back of cabinet for use with included VKVAC vent kit
- See page 42 for optional mobile platform

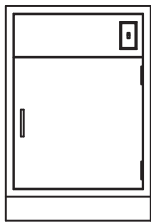

Model	Width
VAC23HF	23"
VAC24HF	24"

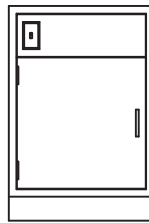

Model	Width
VAC23HLF	23"
VAC24HLF	24"

L = Left Hinged Door

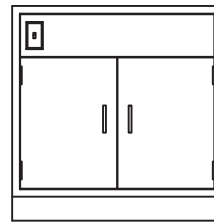

Model	Width
VAC30HF	30"
VAC35HF	35"
VAC42HF	42"
VAC47HF	47"

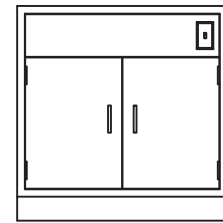

Model	Width
VAC30HF-R	30"
VAC35HF-R	35"
VAC42HF-R	42"
VAC47HF-R	47"

R = Right Hand Switch

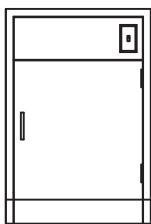
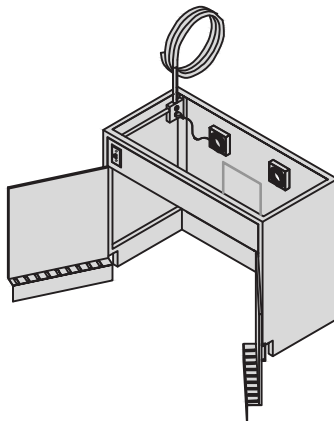

Model	Width
VAC23H	23"
VAC24H	24"

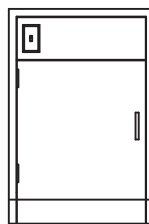

Model	Width
VAC23HL	23"
VAC24HL	24"

L = Left Hinged Door

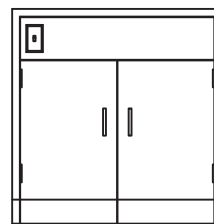

Model	Width
VAC30H	30"
VAC35H	35"
VAC42H	42"
VAC47H	47"

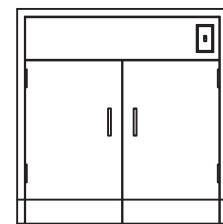

Model	Width
VAC30H-R	30"
VAC35H-R	35"
VAC42H-R	42"
VAC47H-R	47"

R = Right Hand Switch

# SPECIALTY CABINETS

Sitting Height • 29-3/4"

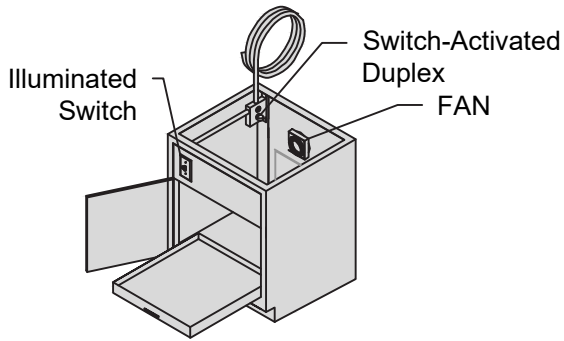

## Vacuum Pump Cabinets

- Models with the suffix "F" come with a floor and pull out bottom shelf
- Designed with pre-wired electrical package, illuminated light switch, interior duplex receptacle, fan, and vented toekick (35", 42", and 47" wide cabinets have 1 electrical package provided with 2 fans)
- One 15 ft. electrical conduit whip is provided with each cabinet
- Sound deadening interior insulation
- A vent hole and removable access panel are provided in the back of cabinet for use with included VKVAC vent kit
- See page 42 for optional mobile platform

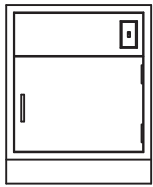

Model	Width
VAC23LF	23"
VAC24LF	24"

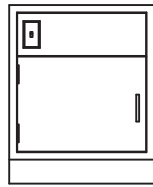

Model	Width
VAC23LLF	23"
VAC24LLF	24"

L = Left Hinged Door

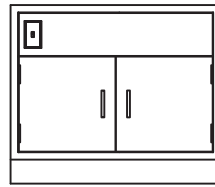

Model	Width
VAC30LF	30"
VAC35LF	35"
VAC42LF	42"
VAC47LF	47"

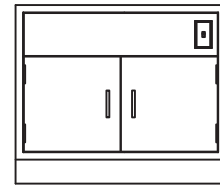

Model	Width
VAC30LF-R	30"
VAC35LF-R	35"
VAC42LF-R	42"
VAC47LF-R	47"

R = Right Hand Switch

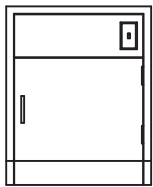
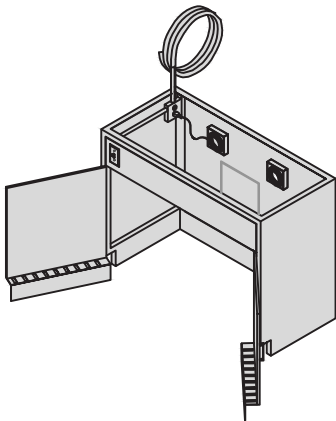

Model	Width
VAC23L	23"
VAC24L	24"

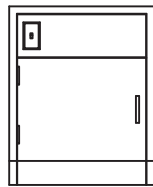

Model	Width
VAC23LL	23"
VAC24LL	24"

L = Left Hinged Door

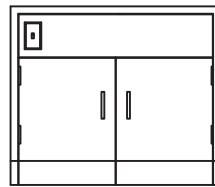

Model	Width
VAC30L	30"
VAC35L	35"
VAC42L	42"
VAC47L	47"

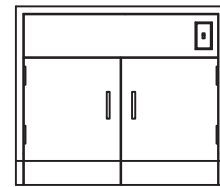

Model	Width
VAC30L-R	30"
VAC35L-R	35"
VAC42L-R	42"
VAC47L-R	47"

R = Right Hand Switch



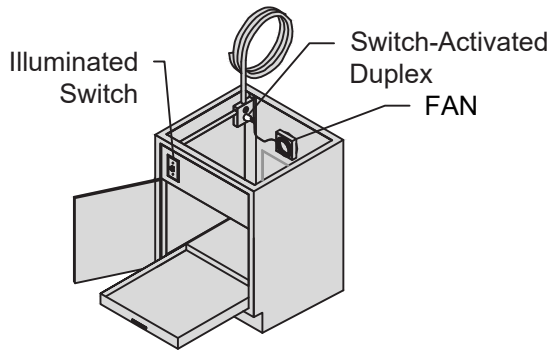

## Vacuum Pump Cabinets

- Models with the suffix "F" come with a floor and pull out bottom shelf
- Designed with pre-wired electrical package, illuminated light switch, interior duplex receptacle, fan, and vented toekick (35", 42", and 47" wide cabinets have 1 electrical package provided with 2 fans)
- One 15 ft. electrical conduit whip is provided with each cabinet
- Sound deadening interior insulation
- A vent hole and removable access panel are provided in the back of cabinet for use with included VKVAC vent kit
- See page 42 for optional mobile platform

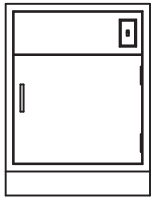

Model	Width
VAC23ADAF	23"
VAC24ADAF	24"

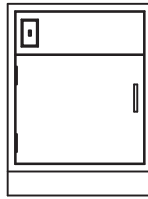

Model	Width
VAC23ADALF	18"
VAC24ADALF	23"

L = Left Hinged Door

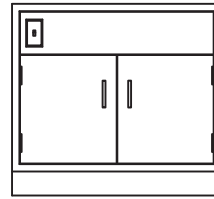

Model	Width
VAC30ADAF	30"
VAC35ADAF	35"
VAC42ADAF	42"
VAC47ADAF	47"

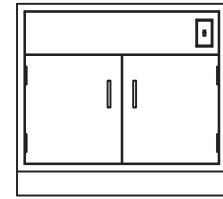

Model	Width
VAC30ADAF-R	30"
VAC35ADAF-R	35"
VAC42ADAF-R	42"
VAC47ADAF-R	47"

R = Right Hand Switch

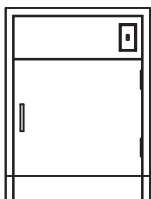
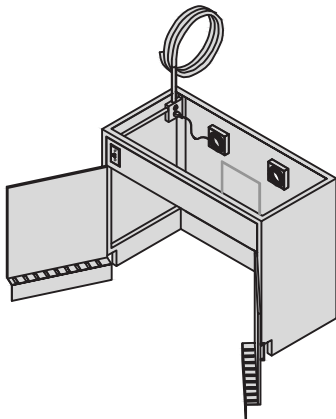

Model	Width
VAC23ADA	23"
VAC24ADA	24"

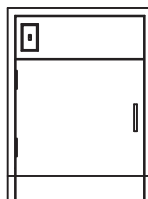

Model	Width
VAC23ADAL	23"
VAC24ADAL	24"

L = Left Hinged Door

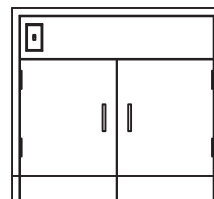

Model	Width
VAC30ADA	30"
VAC35ADA	35"
VAC42ADA	42"
VAC47ADA	47"

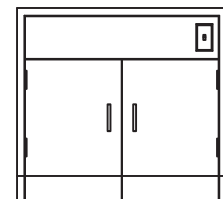

Model	Width
VAC30ADA-R	30"
VAC35ADA-R	35"
VAC42ADA-R	42"
VAC47ADA-R	47"

R = Right Hand Switch

# CASEWORK ACCESSORIES

## Cabinet Options

### Cabinet Locks

- Used on drawers or doors for base, wall, and tall cabinets (not available on ADA sink cabinets)
- Specify -LK at the end of the cabinet model number for locks on all doors and drawers on the cabinet (please specify at time of order if locks are to be **keyed alike**, or **keyed different**)
- Not available on ADA sink cabinets

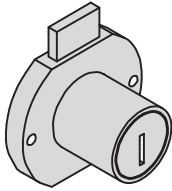

Model  
-LK

### Finished Backs

- Used to finish the back of base cabinets
- Installed at the factory
- Specify -FB at the end of the cabinet model number

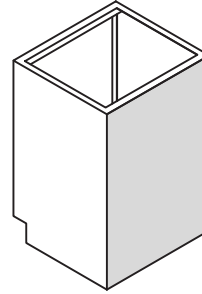

Model  
-FB

### Pull Out Shelves

- Install in base cabinet with open doors or open cabinets
- Pull out shelves have 2" high lips on all 4 sides
- Unless otherwise specified, the shelf will be at bottom of cabinet
- Specify -PS at the end of the cabinet model number

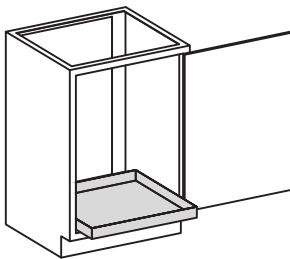

Model  
-PS

### Pull Boards

- Pull boards are available on most base cabinets
- Not available on cabinets that do not have a full height center vertical rail
- Specify for left, right, or both sides for 30" through 47' wide base cabinets
- To add pull boards, specify -PB at the end of the model number

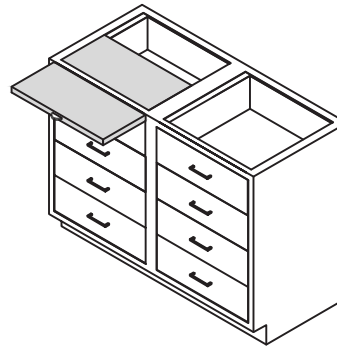

Model  
-PB  
-PBL(Left)  
-PBR(Right)  
-PBB(Both)

### Mobile Platform

- Mobile platform for use with vacuum pump cabinets
- Platform measures 16" (front-to-rear) with 5-1/2" overall height and 2" tall vertical retaining lips on 4 sides
- Includes four casters

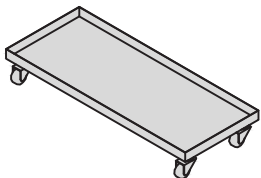

Model	Width
MP-23	18" w Fits 23" Cabinet
MP-24	19" w Fits 24" Cabinet
MP-30	25" w Fits 30" Cabinet
MP-35	30" w Fits 35" Cabinet
MP-42	37" w Fits 42" Cabinet
MP-47	42" w Fits 47" Cabinet

### Lazy Susan

- Fits into DX style corner cabinet

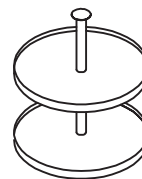

Model	Description
LS-1	1-Tier "Lazy Susan"
LS-2	2 Tier "Lazy Susan"

### Base Filler Panel

- Used between 2 cabinets or between a cabinet and the wall
  - Specify -T at the end of the number if the panel needs to be field trimmed with an SA1 double-slip and single angle
- NOTE: 1" wide fillers are not available with -T variation

#### Standing Height Filler Panel

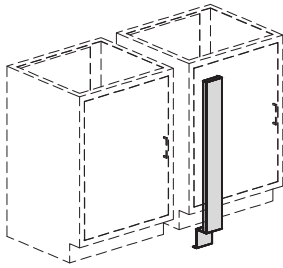

Model	Width	Height
BF1M	1"	35-3/4"
BF4M	4"	35-3/4"
BF6M	6"	35-3/4"
BF8M	8"	35-3/4"
BF12M	12"	35-3/4"
BF14M	14"	35-3/4"
BF18M	18"	35-3/4"

#### ADA Height Filler Panel

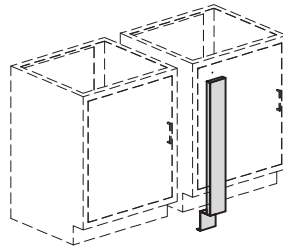

Model	Width	Height
BF1ADA	1"	32"
BF4ADA	4"	32"
BF6ADA	6"	32"
BF8ADA	8"	32"
BF12ADA	12"	32"
BF14ADA	14"	32"
BF18ADA	18"	32"

#### Low Height Filler Panel

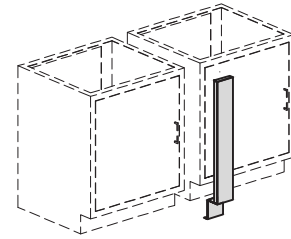

Model	Width	Height
BF1L	1"	29-3/4"
BF4L	4"	29-3/4"
BF6L	6"	29-3/4"
BF8L	8"	29-3/4"
BF12L	12"	29-3/4"
BF14L	14"	29-3/4"
BF18L	18"	29-3/4"

### End Filler Panel

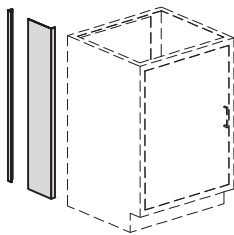

Model	Width	Height
PSF1L	1"	29-3/4"
PSF7L	7"	29-3/4"
PSF13L	13"	29-3/4"
PSF1ADA	1"	32"
PSF7ADA	7"	32"
PSF13ADA	13"	32"
PSF1M	1"	35-3/4"
PSF7M	7"	35-3/4"
PSF13M	13"	35-3/4"

### Island Filler Panel

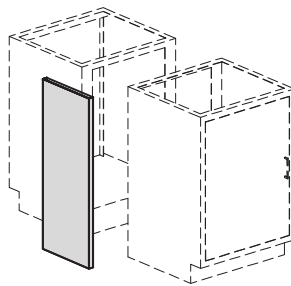

Model	Width	Height
BCF2L	2"	29-3/4"
BCF7L	7"	29-3/4"
BCF14L	14"	29-3/4"
BCF26L	26"	29-3/4"
BCF2ADA	2"	32"
BCF7ADA	7"	32"
BCF14ADA	14"	32"
BCF26ADA	26"	32"
BCF2M	2"	35-3/4"
BCF7M	7"	35-3/4"
BCF14M	14"	35-3/4"
BCF26M	26"	35-3/4"

### Double-Slip Angle

- Field trimmable for use with any height cabinet

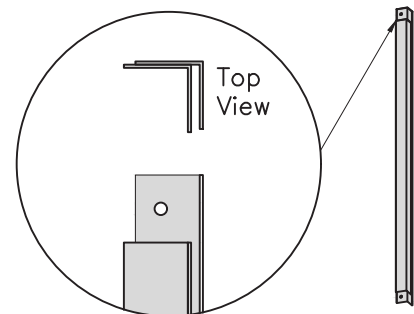

Model	Width	Height
SA1L	1"	25-3/4"
SA1ADA	1"	28-1/8"
SA1	1"	31-3/4"

Includes a single angle.

# CASEWORK ACCESSORIES

## Knee Space Panels

### KSP Filler Panel - applications w/o Apron Rail

- Full height panel, used when there is no rear apron or drawer frame
- For use between 2 cabinets or between a cabinet and wall
- Includes two 1" x 1" angles for installation
- KSPs can be field trimmed

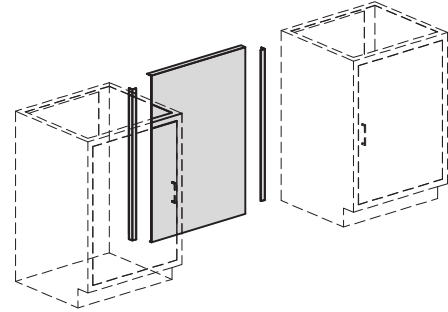

Model	Width	Height
KSP1829	18"	29"
KSP2429	24"	29"
KSP3029	30"	29"
KSP3529	35"	29"
KSP4229	42"	29"
KSP4729	47"	29"
KSP5829	58"	29"
KSP7229	72"	29"

Model	Width	Height
KSP1832	18"	32"
KSP2432	24"	32"
KSP3032	30"	32"
KSP3532	35"	32"
KSP4232	42"	32"
KSP4732	47"	32"
KSP5832	58"	32"
KSP7232	72"	32"

Model	Width	Height
KSP1835	18"	35"
KSP2435	24"	35"
KSP3035	30"	35"
KSP3535	35"	35"
KSP4235	42"	35"
KSP4735	47"	35"
KSP5835	58"	35"
KSP7235	72"	35"

### KSP Filler Panel - applications w/ Apron Rail

- Used when a rear apron or drawer frame is used
- For use between 2 cabinets or between a cabinet and wall
- Includes two 1" x 1" angles for installation
- KSPs can be field trimmed

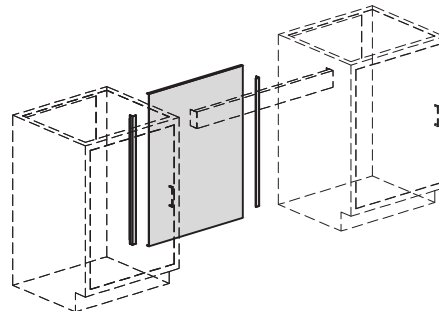

#### Use w/ 29"H Cabinets

Model	Width	Height
KSP1826	18"	26"
KSP2426	24"	26"
KSP3026	30"	26"
KSP3526	35"	26"
KSP4226	42"	26"
KSP4726	47"	26"
KSP5826	58"	26"
KSP7226	72"	26"

#### Use w/ 32"H Cabinets

Model	Width	Height
KSP1828	18"	28"
KSP2428	24"	28"
KSP3028	30"	28"
KSP3528	35"	28"
KSP4228	42"	28"
KSP4728	47"	28"
KSP5828	58"	28"
KSP7228	72"	28"

#### Use w/ 35"H Cabinets

Model	Width	Height
KSP1832	18"	32"
KSP2432	24"	32"
KSP3032	30"	32"
KSP3532	35"	32"
KSP4232	42"	32"
KSP4732	47"	32"
KSP5832	58"	32"
KSP7232	72"	32"

### KSP Filler Panel - applications w/o Apron Rail

- Full height panel, used when there is no rear apron or drawer frame
- For use between 2 cabinets or between a cabinet and wall
- Includes two 1" x 1" angles for installation
- KSPs can be field trimmed

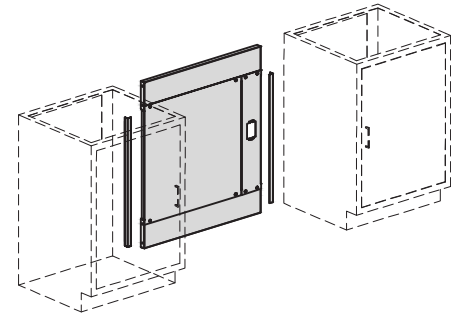

Model	Width	Height
KSP1829E	18"	29"
KSP2429E	24"	29"
KSP3029E	30"	29"
KSP3529E	35"	29"
KSP4229E	42"	29"
KSP4729E	47"	29"
KSP5829E	58"	29"
KSP7229E	72"	29"

Model	Width	Height
KSP1832E	18"	32"
KSP2432E	24"	32"
KSP3032E	30"	32"
KSP3532E	35"	32"
KSP4232E	42"	32"
KSP4732E	47"	32"
KSP5832E	58"	32"
KSP7232E	72"	32"

Model	Width	Height
KSP1835E	18"	35"
KSP2435E	24"	35"
KSP3035E	30"	35"
KSP3535E	35"	35"
KSP4235E	42"	35"
KSP4735E	47"	35"
KSP5835E	58"	35"
KSP7235E	72"	35"

### KSP Filler Panel - applications w/ Apron Rail

- Used when a rear apron or drawer frame is used
- For use between 2 cabinets or between a cabinet and wall
- Includes two 1" x 1" angles for installation
- KSPs can be field trimmed

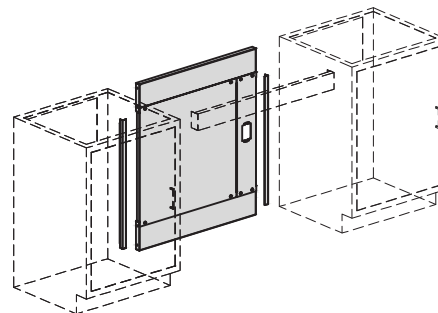

#### Use w/ 29"H Cabinets

Model	Width	Height
KSP1826E	18"	26"
KSP2426E	24"	26"
KSP3026E	30"	26"
KSP3526E	35"	26"
KSP4226E	42"	26"
KSP4726E	47"	26"
KSP5826E	58"	26"
KSP7226E	72"	26"

#### Use w/ 32"H Cabinets

Model	Width	Height
KSP1828E	18"	28"
KSP2428E	24"	28"
KSP3028E	30"	28"
KSP3528E	35"	28"
KSP4228E	42"	28"
KSP4728E	47"	28"
KSP5828E	58"	28"
KSP7228E	72"	28"

#### Use w/ 35"H Cabinets

Model	Width	Height
KSP1832E	18"	32"
KSP2432E	24"	32"
KSP3032E	30"	32"
KSP3532E	35"	32"
KSP4232E	42"	32"
KSP4732E	47"	32"
KSP5832E	58"	32"
KSP7232E	72"	32"

# CASEWORK ACCESSORIES

## Rear Enclosure Panels – REP

### Rear Enclosure Panels

- Rear enclosure panels are used to enclose the back of cabinets or island benches when the counter depth is not deep enough for back-to-back cabinets
- Panels are manufactured in Standing, ADA, and Sitting height panels to match our cabinet heights and include leveling bolts in each corner
- For 2 sided toekick specify 2S at the end of the product number

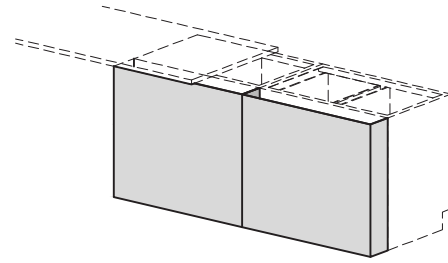

#### Sitting Height 29-3/4" x 6" Deep

Model	Width	Depth	Height
REP18L6	18-1/8"	6"	29-3/4"
REP24L6	24-1/8"	6"	29-3/4"
REP30L6	30"	6"	29-3/4"
REP35L6	35"	6"	29-3/4"
REP42L6	42"	6"	29-3/4"
REP47L6	47"	6"	29-3/4"
REP58L6	58"	6"	29-3/4"

#### Sitting Height 29-3/4" x 12" Deep

Model	Width	Depth	Height
REP18L12	18-1/8"	12"	29-3/4"
REP24L12	24-1/8"	12"	29-3/4"
REP30L12	30"	12"	29-3/4"
REP35L12	35"	12"	29-3/4"
REP42L12	42"	12"	29-3/4"
REP47L12	47"	12"	29-3/4"
REP58L12	58"	12"	29-3/4"

#### ADA Height 32" x 6" Deep

Model	Width	Depth	Height
REP18A6	18-1/8"	6"	32"
REP24A6	24-1/8"	6"	32"
REP30A6	30"	6"	32"
REP35A6	35"	6"	32"
REP42A6	42"	6"	32"
REP47A6	47"	6"	32"
REP58A6	58"	6"	32"

#### ADA Height 32" x 12" Deep

Model	Width	Depth	Height
REP18A12	18-1/8"	12"	32"
REP24A12	24-1/8"	12"	32"
REP30A12	30"	12"	32"
REP35A12	35"	12"	32"
REP42A12	42"	12"	32"
REP47A12	47"	12"	32"
REP58A12	58"	12"	32"

#### Standing Height 35-3/4" x 6" Deep

Model	Width	Depth	Height
REP18H6	18-1/8"	6"	35-3/4"
REP24H6	24-1/8"	6"	35-3/4"
REP30H6	30"	6"	35-3/4"
REP35H6	35"	6"	35-3/4"
REP42H6	42"	6"	35-3/4"
REP47H6	47"	6"	35-3/4"
REP58H6	58"	6"	35-3/4"

#### Standing Height 35-3/4" x 12" Deep

Model	Width	Depth	Height
REP18H12	18-1/8"	12"	35-3/4"
REP24H12	24-1/8"	12"	35-3/4"
REP30H12	30"	12"	35-3/4"
REP35H12	35"	12"	35-3/4"
REP42H12	42"	12"	35-3/4"
REP47H12	47"	12"	35-3/4"
REP58H12	58"	12"	35-3/4"

- 6" deep panels are typically used with 30" deep counter tops for a 1" front and rear overhang

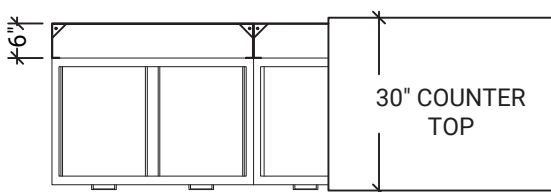

TOP VIEW

- 12" deep panels are typically used with 36" deep counter tops for a 1" front and rear overhang

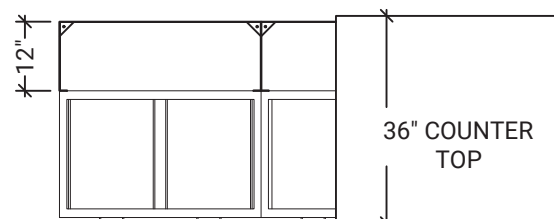

TOP VIEW

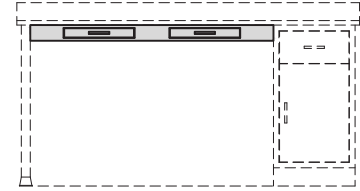
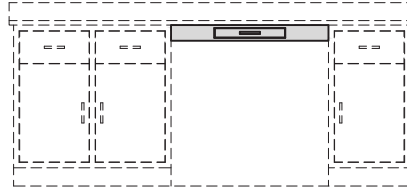
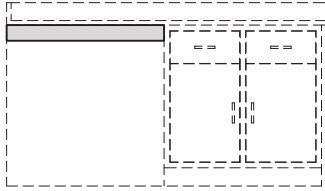

### Apron Rails and Drawer Frames

- Apron rails and drawer frames can be used as a knee space between two cabinets, between a cabinet and a wall, or between a cabinet and legs or end support panels
- Apron rails or drawer frames are **NOT** designed to be used between two sets of legs as a freestanding table. For freestanding tables see our Agility / Mobility section of the catalog
- Drawer frames have a 3-1/2" high frame with a 2" high drawer

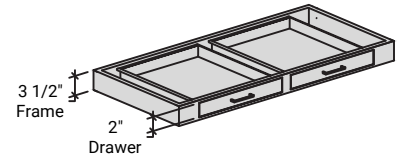
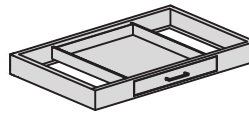
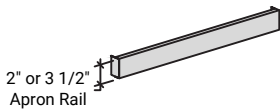

#### Apron Rails

Model	Height	Width
A24	3-1/2"	24"
A30	3-1/2"	30"
A35	3-1/2"	35"
A42	3-1/2"	42"
A47	3-1/2"	47"
A54	3-1/2"	54"
A60	3-1/2"	60"
A66	3-1/2"	66"
A72	3-1/2"	72"
A224	2"	24"
A230	2"	30"
A235	2"	35"
A242	2"	42"
A247	2"	47"
A254	2"	54"
A260	2"	60"
A266	2"	66"
A272	2"	72"

#### Drawer Frames One Pencil Drawer

Model	Width	Depth
DH-1-24A	24"	22"
DH-1-24B	24"	28"
DH-1-30A	30"	22"
DH-1-30B	30"	28"
DH-1-35A	35"	22"
DH-1-35B	35"	28"
DH-1-42A	42"	22"
DH-1-42B	42"	28"
DH-1-47A	47"	22"
DH-1-47B	47"	28"

#### Drawer Frames Two Pencil Drawer

Model	Width	Depth
DH-2-47A	47"	22"
DH-2-47B	47"	28"
DH-2-54A	54"	22"
DH-2-54B	54"	28"
DH-2-58A	58"	22"
DH-2-58B	58"	28"
DH-2-60A	60"	22"
DH-2-60B	60"	28"
DH-2-66A	66"	22"
DH-2-66B	66"	28"

### Toe Space Filler Panel

- Used at corner where cabinets meet at a 90° angle
- 18 ga. steel painted to match cabinets

Model  
TSF

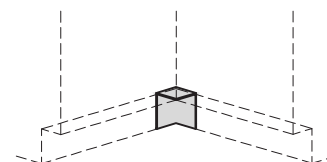

# CASEWORK ACCESSORIES

## Leg Assemblies & Countertop Supports

### Single Leg



- Used with apron rails or drawer frames
- 2" x 2" 16 ga. construction
- Leg levelers and vinyl shoe included

Model	Height
L30	29-3/4"
L32	32"
L36	35-3/4"

### Single Flanged Leg



- Used to provide added support of counter tops
- 4" x 4" plate, offset at the top with holes for attachment to counter top
- Leg levelers and vinyl shoe included

Model	Height
FL30	29-3/4"
FL32	32"
FL36	35-3/4"

### H-Leg

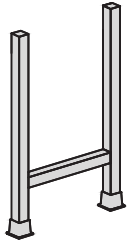

- Used with apron rails or drawer frames
- Leg levelers and vinyl shoes provided

Model	Height	Depth
HL30A	29-3/4"	22"
HL30B	29-3/4"	28"
HL32A	32"	22"
HL32B	32"	28"
HL36A	35-3/4"	22"
HL36B	35-3/4"	28"

### Flanged H-Leg

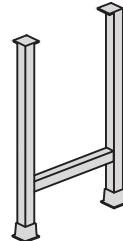

- Used to provide added support of counter tops
- 4" x 4" plates, offset at the top with holes for attachment to countertop
- Leg levelers and vinyl shoe included

Model	Height	Depth
FHL30A	29-3/4"	22"
FHL30B	29-3/4"	28"
FHL32A	32"	22"
FHL32B	32"	28"
FHL36A	35-3/4"	22"
FHL36B	35-3/4"	28"

### Countertop Support Brackets

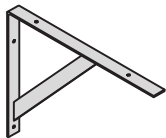

- Painted to match casework
- In-wall backing required for support

Model	Height	Depth
CSB21	20"	21"
CSB27	20"	27"
EH1824	18"	24"

### End Support Panel

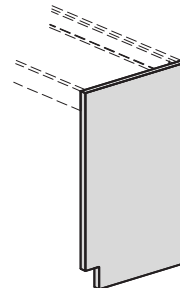

- Used in place of legs on one end of apron rails or drawer frames
- 1-1/4" wide
- Leg levelers provided

Model	Height	Depth
HGL30A	29-3/4"	22"
HGL30B	29-3/4"	28"
HGL32A	32"	22"
HGL32B	32"	28"
HGL36A	35-3/4"	22"
HGL36B	35-3/4"	28"



### Function & Design

- HLS offers a variety of Umbilical Pipe Enclosures used to conceal service lines that come down from the ceiling at either walls or at island locations
- Floor to ceiling models are also available
- One side of enclosure is removable for access to utilities
- Painted steel construction to match the cabinets
- Umbilicals are also available in Architectural Resin, Plastic Laminate, and Stainless Steel

### Island Bench Umbilicals

Note: A verified ceiling height is required to determine the correct umbilical height

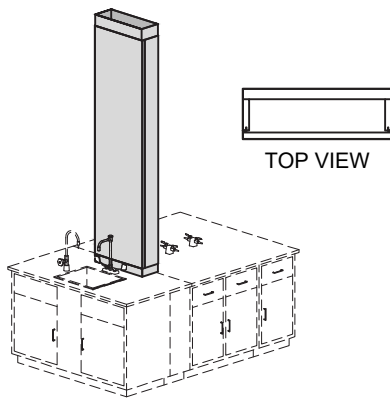

Model	Width	Depth	Height	Model	Width	Depth	Height
UMI180665	18"	6"	65.25"	UMI240665	24"	6"	65.25"
UMI180669	18"	6"	69"	UMI240669	24"	6"	69"
UMI180671	18"	6"	71.25"	UMI240671	24"	6"	71.25"
UMI180675	18"	6"	75"	UMI240675	24"	6"	75"
UMI180677	18"	6"	77.25"	UMI240677	24"	6"	77.25"
UMI180681	18"	6"	81"	UMI240681	24"	6"	81"
UMI180683	18"	6"	83.25"	UMI240683	24"	6"	83.25"
UMI180689	18"	6"	89.25"	UMI240689	24"	6"	89.25"
UMI180693	18"	6"	93"	UMI240693	24"	6"	93"
UMI180695	18"	6"	95.25"	UMI240695	24"	6"	95.25"
UMI180865	18"	8"	65.25"	UMI240865	24"	8"	65.25"
UMI180869	18"	8"	69"	UMI240869	24"	8"	69"
UMI180871	18"	8"	71.25"	UMI240871	24"	8"	71.25"
UMI180875	18"	8"	75"	UMI240875	24"	8"	75"
UMI180877	18"	8"	77.25"	UMI240877	24"	8"	77.25"
UMI180881	18"	8"	81"	UMI240881	24"	8"	81"
UMI180883	18"	8"	83.25"	UMI240883	24"	8"	83.25"
UMI180889	18"	8"	89.25"	UMI240889	24"	8"	89.25"
UMI180893	18"	8"	93"	UMI240893	24"	8"	93"
UMI180895	18"	8"	95.25"	UMI240895	24"	8"	95.25"
UMI181065	18"	10"	65.25"	UMI241065	24"	10"	65.25"
UMI181069	18"	10"	69"	UMI241069	24"	10"	69"
UMI181071	18"	10"	71.25"	UMI241071	24"	10"	71.25"
UMI181075	18"	10"	75"	UMI241075	24"	10"	75"
UMI181077	18"	10"	77.25"	UMI241077	24"	10"	77.25"
UMI181081	18"	10"	81"	UMI241081	24"	10"	81"
UMI181083	18"	10"	83.25"	UMI241083	24"	10"	83.25"
UMI181089	18"	10"	89.25"	UMI241089	24"	10"	89.25"
UMI181093	18"	10"	93"	UMI241093	24"	10"	93"
UMI181095	18"	10"	95.25"	UMI241095	24"	10"	95.25"

### Wall Bench Umbilicals

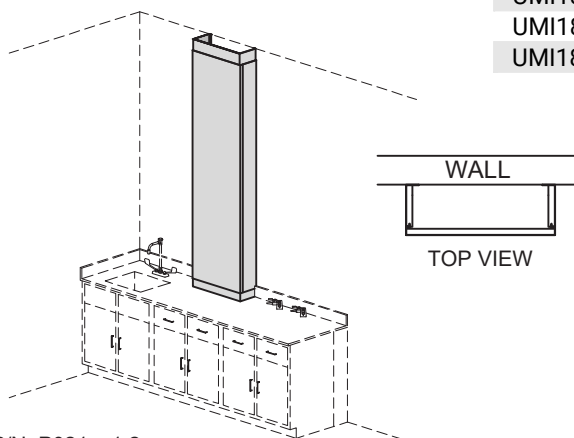

Same as above except substitute "W" for the "I" in the part number prefix (UMI)

Example:

Model	Width	Depth	Height
UMW180665	18"	6"	65.25"

# WALL CABINETS

## Construction Details

### HLS Wall Cabinets

Hanson wall cabinets are available in a variety of styles and sizes designed to meet your specific applications. They are designed for maximum storage capacity, and access.

- 24", 30", 36" and 48" high wall cabinets
- Choice of 13" or 16" deep cabinets
- Available in solid panel, framed or frameless glass doors and open style wall cabinets
- Hinged or sliding door options

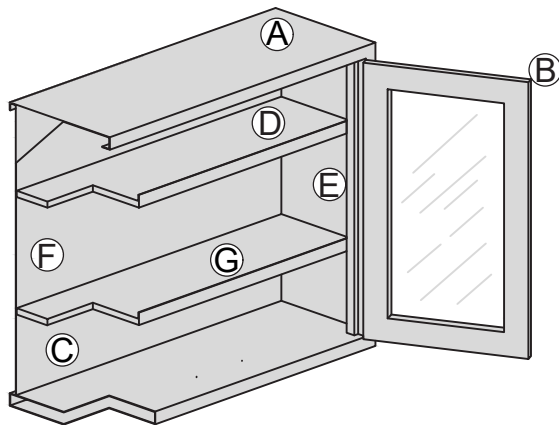
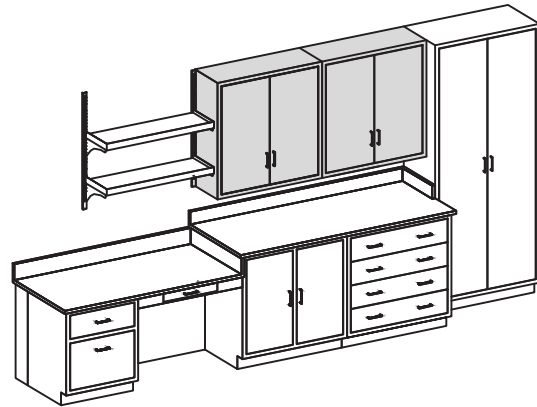

### HLS Features and Benefits

- Ⓐ Cabinet body design accepts multiple styles of doors.
- Ⓑ 18 ga. double door fronts, with sound deadening full channeled edges. Glass door applications feature 1/4" thick annealed clear glass.
- Ⓒ 18 ga. cabinet bodies with flush seamless welded face.
- Ⓓ 20 ga. adjustable shelves are included in open and cupboard cabinets.
- Ⓔ Stainless steel 5 knuckle hinges on cabinet doors that close against neoprene rubber bumpers.
- Ⓕ HLS cabinets have electrostatically applied, baked on powder coated epoxy paint finish for superior performance.
- Ⓖ Front shelf lips are included on all shelves.

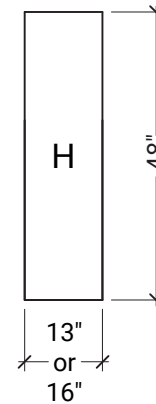
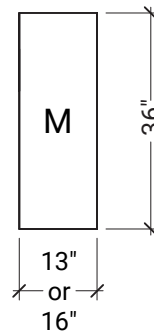
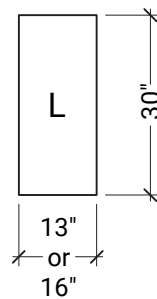
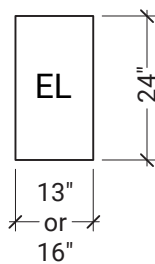

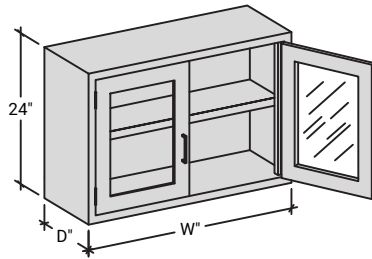

## The HLS Advantages

- Inset steel - flush face construction
- Cabinets are 24" high - width and depth as shown below
- Furnished with 1 adjustable shelf

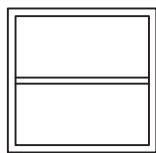

### Open Cabinets

Model	Depth	Width
G18EL	13"	18-3/4"
G18EL16	16"	18-3/4"
G24EL	13"	24-3/4"
G24EL16	16"	24-3/4"
G30EL	13"	30"
G30EL16	16"	30"
G35EL	13"	35"
G35EL16	16"	35"
G42EL	13"	42"
G42EL16	16"	42"
G47EL	13"	47"
G47EL16	16"	47"

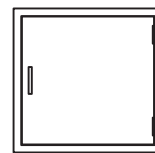

### Hinged Solid Doors

Model	Depth	Width
A18EL	13"	18-3/4"
A18EL16	16"	18-3/4"
A24EL	13"	24-3/4"
A24EL16	16"	24-3/4"

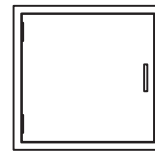

### Left Hinged Solid Doors

Model	Depth	Width
A18ELL	13"	18-3/4"
A18ELL16	16"	18-3/4"
A24ELL	13"	24-3/4"
A24ELL16	16"	24-3/4"

L = Left Hinged Door

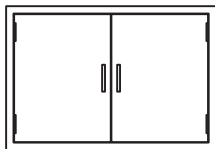

### Hinged Solid Doors

Model	Depth	Width
B30EL	13"	30"
B30EL16	16"	30"
B35EL	13"	35"
B35EL16	16"	35"
B42EL	13"	42"
B42EL16	16"	42"
B47EL	13"	47"
B47EL16	16"	47"

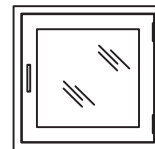

### Framed Glass Hinged Doors

Model	Depth	Width
D18EL	13"	18-3/4"
D18EL16	16"	18-3/4"
D24EL	13"	24-3/4"
D24EL16	16"	24-3/4"

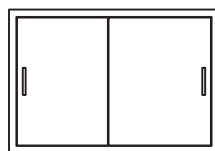

### Sliding Solid Doors

Model	Depth	Width
C30EL	13"	30"
C30EL16	16"	30"
C35EL	13"	35"
C35EL16	16"	35"
C42EL	13"	42"
C42EL16	16"	42"
C47EL	13"	47"
C47EL16	16"	47"

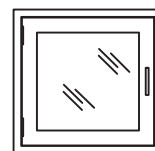

### Framed Glass Left Hinged Doors

Model	Depth	Width
D18ELL	13"	18-3/4"
D18ELL16	16"	18-3/4"
D24ELL	13"	24-3/4"
D24ELL16	16"	24-3/4"

L = Left Hinged Door

# WALL CABINETS

Extra Low • 24"

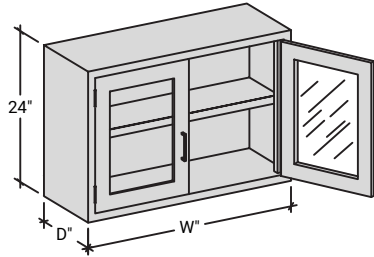

## The HLS Advantages

- Inset steel - flush face construction
- Cabinets are 24" high - width and depth as shown below
- Furnished with 1 adjustable shelf

### Framed Glass Hinged Doors

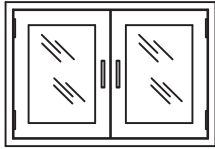

Model	Depth	Width
E30EL	13"	30"
E30EL16	16"	30"
E35EL	13"	35"
E35EL16	16"	35"
E42EL	13"	42"
E42EL16	16"	42"
E47EL	13"	47"
E47EL16	16"	47"

### Frameless Glass Sliding Doors

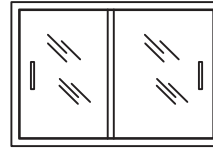

Model	Depth	Width
FAL30EL	13"	30"
FAL30EL16	16"	30"
FAL35EL	13"	35"
FAL35EL16	16"	35"
FAL42EL	13"	42"
FAL42EL16	16"	42"
FAL47EL	13"	47"
FAL47EL16	16"	47"

### Framed Glass Sliding Doors

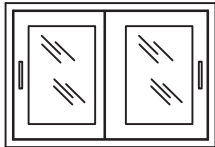

Model	Depth	Width
F30EL	13"	30"
F30EL16	16"	30"
F35EL	13"	35"
F35EL16	16"	35"
F42EL	13"	42"
F42EL16	16"	42"
F47EL	13"	47"
F47EL16	16"	47"

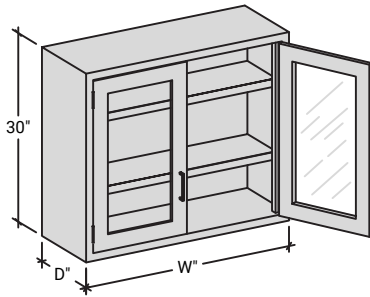

## The HLS Advantages

- Inset steel - flush face construction
- Cabinets are 30" high - width and depth as shown below
- Furnished with 2 adjustable shelf

### Open Cabinets

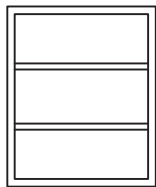

Model	Depth	Width
G18L	13"	18-3/4"
G18L16	16"	18-3/4"
G24L	13"	24-3/4"
G24L16	16"	24-3/4"
G30L	13"	30"
G30L16	16"	30"
G35L	13"	35"
G35L16	16"	35"
G42L	13"	42"
G42L16	16"	42"
G47L	13"	47"
G47L16	16"	47"

### Hinged Solid Doors

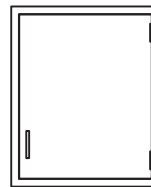

Model	Depth	Width
A18L	13"	18-3/4"
A18L16	16"	18-3/4"
A24L	13"	24-3/4"
A24L16	16"	24-3/4"

### Left Hinged Solid Doors

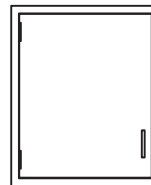

Model	Depth	Width
A18LL	13"	18-3/4"
A18LL16	16"	18-3/4"
A24LL	13"	24-3/4"
A24LL16	16"	24-3/4"

### Hinged Solid Doors

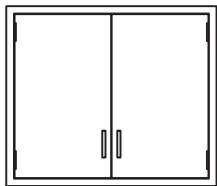

Model	Depth	Width
B30L	13"	30"
B30L16	16"	30"
B35L	13"	35"
B35L16	16"	35"
B42L	13"	42"
B42L16	16"	42"
B47L	13"	47"
B47L16	16"	47"

### Framed Glass Hinged Doors

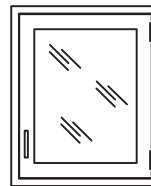

Model	Depth	Width
D18L	13"	18-3/4"
D18L16	16"	18-3/4"
D24L	13"	24-3/4"
D24L16	16"	24-3/4"

### Sliding Solid Doors

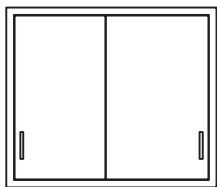

Model	Depth	Width
C30L	13"	30"
C30L16	16"	30"
C35L	13"	35"
C35L16	16"	35"
C42L	13"	42"
C42L16	16"	42"
C47L	13"	47"
C47L16	16"	47"

### Framed Glass Left Hinged Doors

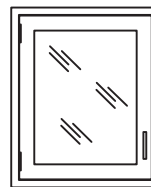

Model	Depth	Width
D18LL	13"	18-3/4"
D18LL16	16"	18-3/4"
D24LL	13"	24-3/4"
D24LL16	16"	24-3/4"

# WALL CABINETS

Low • 30"

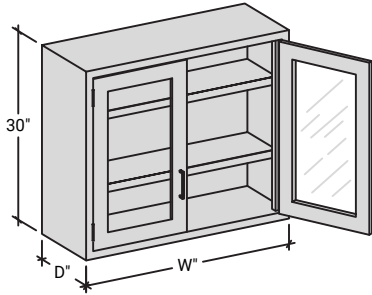

## The HLS Advantages

- Inset steel - flush face construction
- Cabinets are 30" high - width and depth as shown below
- Furnished with 2 adjustable shelf

### Framed Glass Hinged Doors

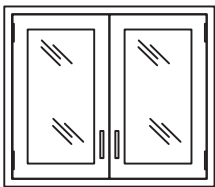

Model	Depth	Width
E30L	13"	30"
E30L16	16"	30"
E35L	13"	35"
E35L16	16"	35"
E42L	13"	42"
E42L16	16"	42"
E47L	13"	47"
E47L16	16"	47"

### Frameless Glass Sliding Doors

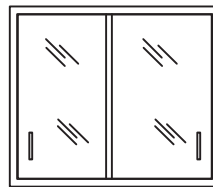

Model	Depth	Width
FAL30L	13"	30"
FAL30L16	16"	30"
FAL35L	13"	35"
FAL35L16	16"	35"
FAL42L	13"	42"
FAL42L16	16"	42"
FAL47L	13"	47"
FAL47L16	16"	47"

### Framed Glass Sliding Doors

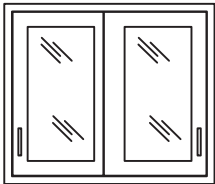

Model	Depth	Width
F30L	13"	30"
F30L16	16"	30"
F35L	13"	35"
F35L16	16"	35"
F42L	13"	42"
F42L16	16"	42"
F47L	13"	47"
F47L16	16"	47"

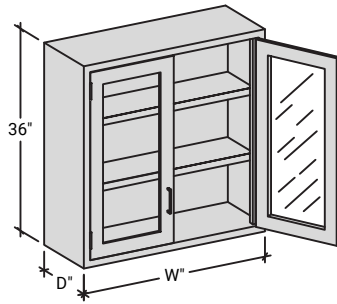

## The HLS Advantages

- Inset steel - flush face construction
- Cabinets are 36" high - width and depth as shown below
- Furnished with 2 adjustable shelf

### Open Cabinets

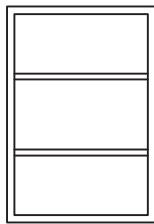

Model	Depth	Width
G18M	13"	18-3/4"
G18M16	16"	18-3/4"
G24M	13"	24-3/4"
G24M16	16"	24-3/4"
G30M	13"	30"
G30M16	16"	30"
G35M	13"	35"
G35M16	16"	35"
G42M	13"	42"
G42M16	16"	42"
G47M	13"	47"
G47M16	16"	47"

### Hinged Solid Doors

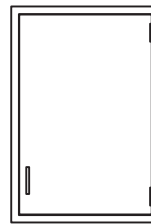

Model	Depth	Width
A18M	13"	18-3/4"
A18M16	16"	18-3/4"
A24M	13"	24-3/4"
A24M16	16"	24-3/4"

### Left Hinged Solid Doors

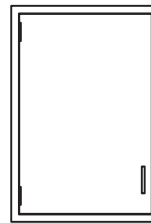

Model	Depth	Width
A18ML	13"	18-3/4"
A18ML16	16"	18-3/4"
A24ML	13"	24-3/4"
A24ML16	16"	24-3/4"

### Hinged Solid Doors

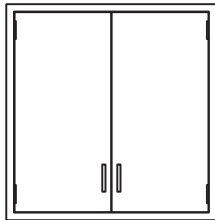

Model	Depth	Width
B30M	13"	30"
B30M16	16"	30"
B35M	13"	35"
B35M16	16"	35"
B42M	13"	42"
B42M16	16"	42"
B47M	13"	47"
B47M16	16"	47"

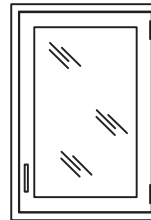

### Framed Glass Hinged Doors

Model	Depth	Width
D18M	13"	18-3/4"
D18M16	16"	18-3/4"
D24M	13"	24-3/4"
D24M16	16"	24-3/4"

### Sliding Solid Doors

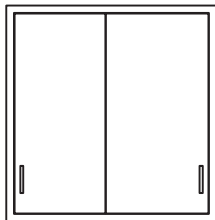

Model	Depth	Width
C30M	13"	30"
C30M16	16"	30"
C35M	13"	35"
C35M16	16"	35"
C42M	13"	42"
C42M16	16"	42"
C47M	13"	47"
C47M16	16"	47"

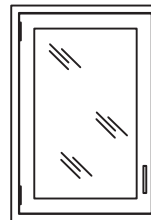

### Framed Glass Left Hinged Doors

Model	Depth	Width
D18ML	13"	18-3/4"
D18ML16	16"	18-3/4"
D24ML	13"	24-3/4"
D24ML16	16"	24-3/4"

# WALL CABINETS

Medium • 36"

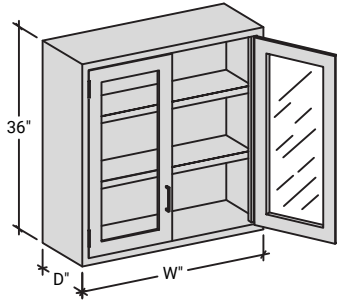

## The HLS Advantages

- Inset steel - flush face construction
- Cabinets are 36" high - width and depth as shown below
- Furnished with 2 adjustable shelf

### Framed Glass Hinged Doors

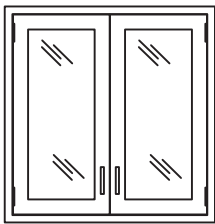

Model	Depth	Width
E30M	13"	30"
E30M16	16"	30"
E35M	13"	35"
E35M16	16"	35"
E42M	13"	42"
E42M16	16"	42"
E47M	13"	47"
E47M16	16"	47"

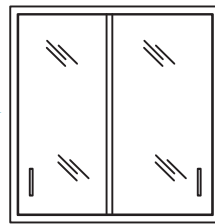

### Frameless Glass Sliding Doors

Model	Depth	Width
FAL30M	13"	30"
FAL30M16	16"	30"
FAL35M	13"	35"
FAL35M16	16"	35"
FAL42M	13"	42"
FAL42M16	16"	42"
FAL47M	13"	47"
FAL47M16	16"	47"

### Framed Glass Sliding Doors

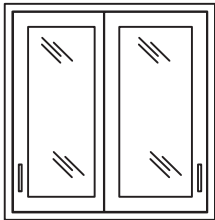

Model	Depth	Width
F30M	13"	30"
F30M16	16"	30"
F35M	13"	35"
F35M16	16"	35"
F42M	13"	42"
F42M16	16"	42"
F47M	13"	47"
F47M16	16"	47"



High • 48"

[hansonlab.com](http://hansonlab.com) • 805-498-3121

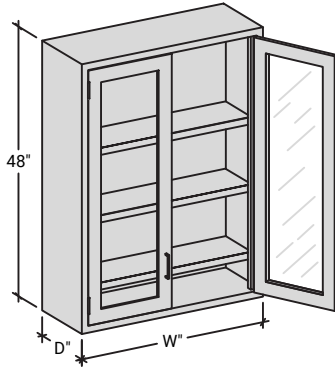

## The HLS Advantages

- Inset steel - flush face construction
- Cabinets are 48" high - width and depth as shown below
- Furnished with 3 adjustable shelf

### Open Cabinets

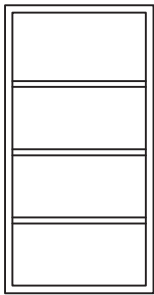

Model	Depth	Width
G18H	13"	18-3/4"
G18H16	16"	18-3/4"
G24H	13"	24-3/4"
G24H16	16"	24-3/4"
G30H	13"	30"
G30H16	16"	30"
G35H	13"	35"
G35H16	16"	35"
G42H	13"	42"
G42H16	16"	42"
G47H	13"	47"
G47H16	16"	47"

### Hinged Solid Doors



Model	Depth	Width
A18H	13"	18-3/4"
A18H16	16"	18-3/4"
A24H	13"	24-3/4"
A24H16	16"	24-3/4"

### Left Hinged Solid Doors



Model	Depth	Width
A18HL	13"	18-3/4"
A18HL16	16"	18-3/4"
A24HL	13"	24-3/4"
A24HL16	16"	24-3/4"

### Hinged Solid Doors

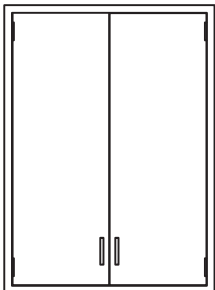

Model	Depth	Width
B30H	13"	30"
B30H16	16"	30"
B35H	13"	35"
B35H16	16"	35"
B42H	13"	42"
B42H16	16"	42"
B47H	13"	47"
B47H16	16"	47"

### Sliding Solid Doors

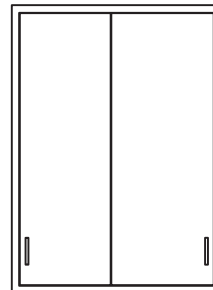

Model	Depth	Width
C30H	13"	30"
C30H16	16"	30"
C35H	13"	35"
C35H16	16"	35"
C42H	13"	42"
C42H16	16"	42"
C47H	13"	47"
C47H16	16"	47"

# WALL CABINETS

High • 48"

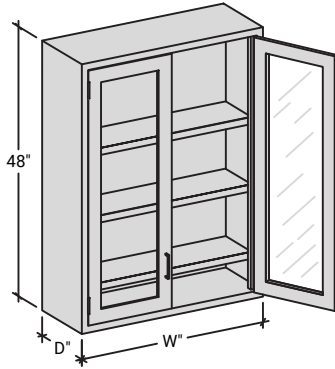

## The HLS Advantages

- Inset steel - flush face construction
- Cabinets are 48" high - width and depth as shown below
- Furnished with 3 adjustable shelf

### Framed Glass Hinged Doors

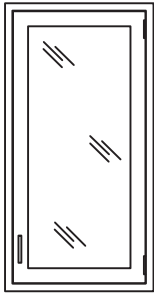

Model	Depth	Width
D18H	13"	18-3/4"
D18H16	16"	18-3/4"
D24H	13"	24-3/4"
D24H16	16"	24-3/4"

### Framed Glass Left Hinged Doors

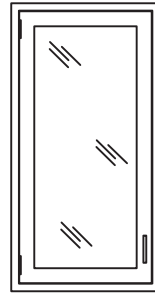

Model	Depth	Width
D18HL	13"	18-3/4"
D18HL16	16"	18-3/4"
D24HL	13"	24-3/4"
D24HL16	16"	24-3/4"

### Framed Glass Hinged Doors

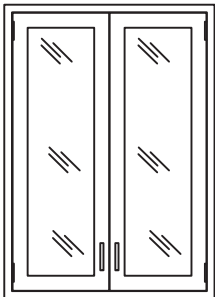

Model	Depth	Width
E30H	13"	30"
E30H16	16"	30"
E35H	13"	35"
E35H16	16"	35"
E42H	13"	42"
E42H16	16"	42"
E47H	13"	47"
E47H16	16"	47"

### Framed Glass Sliding Doors

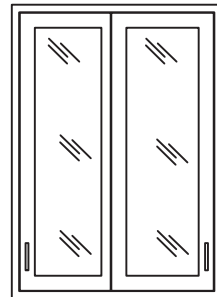

Model	Depth	Width
F30H	13"	30"
F30H16	16"	30"
F35H	13"	35"
F35H16	16"	35"
F42H	13"	42"
F42H16	16"	42"
F47H	13"	47"
F47H16	16"	47"

### Frameless Sliding Doors

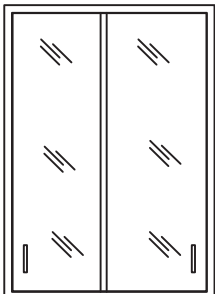

Model	Depth	Width
FAL30H	13"	30"
FAL30H16	16"	30"
FAL35H	13"	35"
FAL35H16	16"	35"
FAL42H	13"	42"
FAL42H16	16"	42"
FAL47H	13"	47"
FAL47H16	16"	47"

### Wall Cabinet Front Filler Panel

- For use between 2 cabinets or between cabinet & wall
- Specify T if the panel needs to be field trimmed with an SA1WC double-slip angle

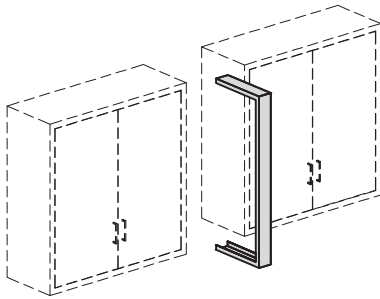

Model	Width	Height	Depth
WCF1EL13	1"	24"	13"
WCF1L13	1"	30"	13"
WCF1M13	1"	36"	13"
WCF1H13	1"	48"	13"
WCF3EL13	3"	24"	13"
WCF3L13	3"	30"	13"
WCF3M13	3"	36"	13"
WCF3H13	3"	48"	13"
WCF6EL13	6"	24"	13"
WCF6L13	6"	30"	13"
WCF6M13	6"	36"	13"
WCF6H13	6"	48"	13"
WCF12EL13	12"	24"	13"
WCF12L13	12"	30"	13"
WCF12M13	12"	36"	13"
WCF12H13	12"	48"	13"
WCF1EL16	1"	24"	16"
WCF1L16	1"	30"	16"
WCF1M16	1"	36"	16"
WCF1H16	1"	48"	16"
WCF3EL16	3"	24"	16"
WCF3L16	3"	30"	16"
WCF3M16	3"	36"	16"
WCF3H16	3"	48"	16"
WCF6EL16	6"	24"	16"
WCF6L16	6"	30"	16"
WCF6M16	6"	36"	16"
WCF6H16	6"	48"	16"
WCF12EL16	12"	24"	16"
WCF12L16	12"	30"	16"
WCF12M16	12"	36"	16"
WCF12H16	12"	48"	16"

### Wall Cabinet Corner Filler Panel

- Used to close top and bottom where 2 upper cabinets are joined at right angles
- Supplied in sets of two

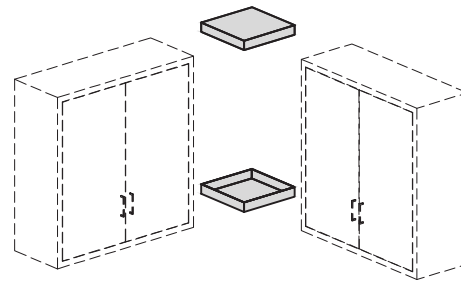

Model	Width	Depth
WCCF13	13"	13"
WCCF16	16"	16"
WCCF1316	13"	16"

### Wall Cabinet Slip Angle

- Field trimmable for all height wall cabinets

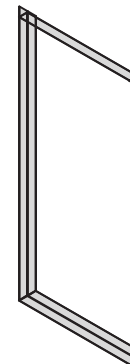

Model	Width	Height
SA1WC24	1"	24"
SA1WC30	1"	30"
SA1WC36	1"	36"
SA1WC48	1"	48"

Includes a single angle.

# WALL CABINET ACCESSORIES

## Ceiling Enclosures & Sloping Tops

### Wall Cabinet Ceiling Enclosures

- Used to enclose the space between the top of the wall cabinet and the ceiling
- Angles for installation and trimmable scribes are provided
- A verified ceiling height is required to determine the correct enclosure height

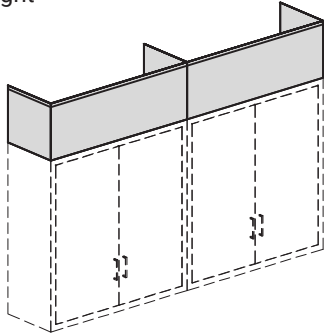

Model	Width	Depth	Height
CEW1813-18	18.75"	13"	18"
CEW2413-18	24.75"	13"	18"
CEW3013-18	30"	13"	18"
CEW3513-18	35"	13"	18"
CEW4213-18	42"	13"	18"
CEW4713-18	47"	13"	18"
CEW1816-18	18.75"	16"	18"
CEW2416-18	24.75"	16"	18"
CEW3016-18	30"	16"	18"
CEW3516-18	35"	16"	18"
CEW4216-18	42"	16"	18"
CEW4716-18	47"	16"	18"
CEW1813-24	18.75"	13"	24"
CEW2413-24	24.75"	13"	24"
CEW3013-24	30"	13"	24"
CEW3513-24	35"	13"	24"
CEW4213-24	42"	13"	24"
CEW4713-24	47"	13"	24"
CEW1816-24	18.75"	16"	24"
CEW2416-24	24.75"	16"	24"
CEW3016-24	30"	16"	24"
CEW3516-24	35"	16"	24"
CEW4216-24	42"	16"	24"
CEW4716-24	47"	16"	24"
CEW1813-30	18.75"	13"	30"
CEW2413-30	24.75"	13"	30"
CEW3013-30	30"	13"	30"
CEW3513-30	35"	13"	30"
CEW4213-30	42"	13"	30"
CEW4713-30	47"	13"	30"
CEW1816-30	18.75"	16"	30"
CEW2416-30	24.75"	16"	30"
CEW3016-30	30"	16"	30"
CEW3516-30	35"	16"	30"
CEW4216-30	42"	16"	30"
CEW4716-30	47"	16"	30"

### Sloping Tops

- Used to enclose the space between the top of the wall cabinet and the ceiling

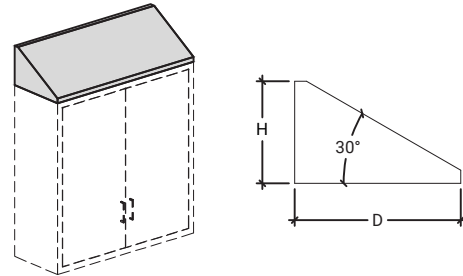

Model	Width	Depth	Height
A4810-18	18.75"	13"	8.344"
A4810-24	24.75"	13"	8.344"
A4810-30	30"	13"	8.344"
A4810-35	35"	13"	8.344"
A4810-42	42"	13"	8.344"
A4810-47	47"	13"	8.344"
A4820-18	18.75"	16"	9.910"
A4820-24	24.75"	16"	9.910"
A4820-30	30"	16"	9.910"
A4820-35	35"	16"	9.910"
A4820-42	42"	16"	9.910"
A4820-47	47"	16"	9.910"

### Corner Sloping Top

- Used in corners with sloping tops and where wall cabinets are at right angles

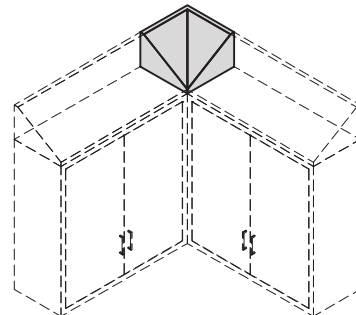

Model	Depth	Height
CSL13	13"	8.344"
CSL16	16"	9.910"

### HLS Tall Cabinets

Hanson tall cabinets are available in a variety of styles and sizes designed to meet your specific applications. They are designed for maximum storage capacity, and access.

- Tall cabinets are 84" high
- Choice of 18" or 23" deep cabinets
- Available in solid panel or framed glass in both hinged and sliding doors
- Instrument and wardrobe cabinets are also available

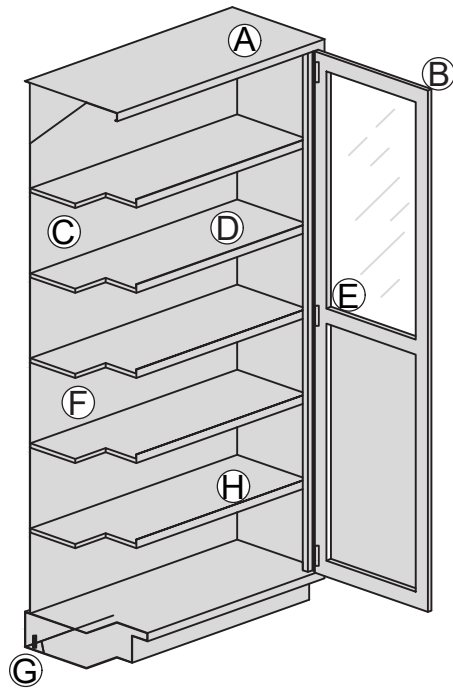
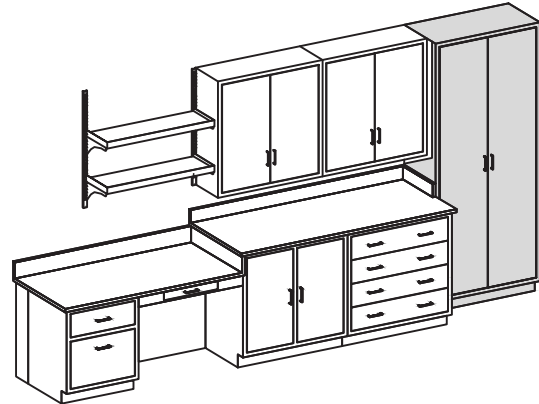

### HLS Features and Benefits

- Ⓐ Cabinet body design accepts multiple styles of doors.
- Ⓑ 18 ga. double door fronts, with sound deadening full channeled edges. Glass door applications feature 1/4" thick annealed clear glass.
- Ⓒ 18 ga. cabinet bodies with flush seamless welded face.
- Ⓓ 5 each 20 ga. adjustable shelves are included in open and door cabinets. Shelves have welded hat-channels in cabinets 35" and over.
- Ⓔ Stainless steel 5 knuckle hinges on cabinet doors that close against neoprene rubber bumpers.
- Ⓕ HLS cabinets have electrostatically applied, baked on powder coated epoxy paint finish for superior performance.
- Ⓖ 14 ga. gusset plates with hex-head leveling bolts at each corner.
- Ⓗ Front shelf lips are included on all shelves.

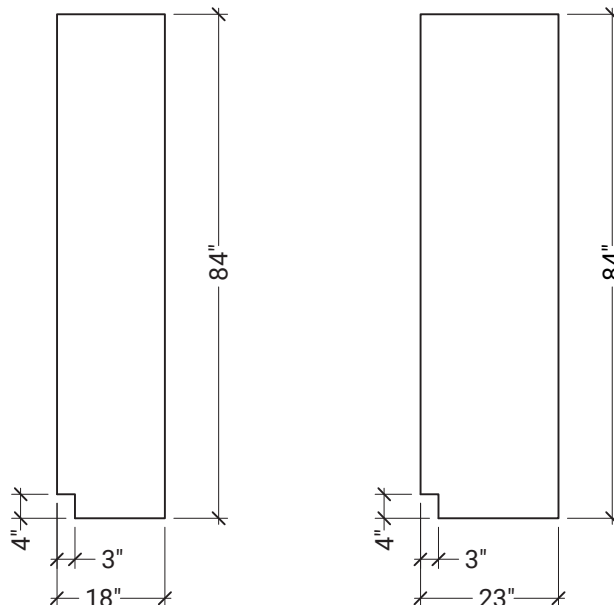

# TALL STORAGE CABINETS

Height • 84"

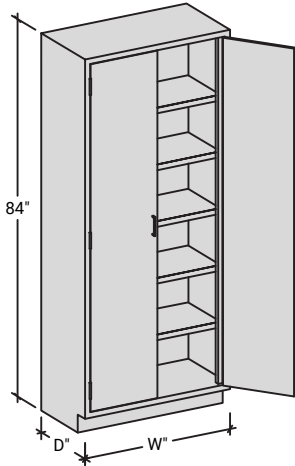

## Solid Door - Tall Cabinets

- Inset steel - flush face construction
- Tall storage cabinets are 84" high - width and depth as shown below
- Tall cabinets have 5 adjustable shelves

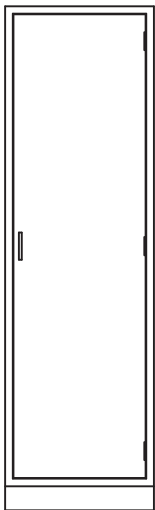

### Hinged Doors

Model	Depth	Width
H18HA	18"	18-3/4"
H18HB	23"	18-3/4"
H24HA	18"	24-3/4"
H24HB	23"	24-3/4"

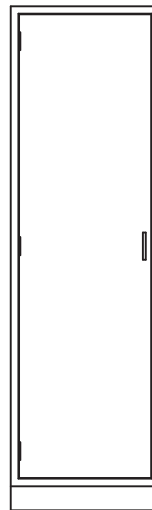

### Left Hinged Doors

Model	Depth	Width
H18HAL	18"	18-3/4"
H18HBL	23"	18-3/4"
H24HAL	18"	24-3/4"
H24HBL	23"	24-3/4"

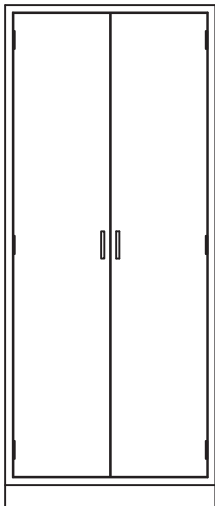

### Hinged Doors

Model	Depth	Width
I30HA	18"	30"
I30HB	23"	30"
I35HA	18"	35"
I35HB	23"	35"
I42HA	18"	42"
I42HB	23"	42"
I47HA	18"	47"
I47HB	23"	47"

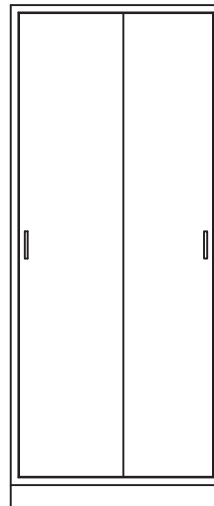

### Sliding Doors

Model	Depth	Width
J30HA	18"	30"
J30HB	23"	30"
J35HA	18"	35"
J35HB	23"	35"
J42HA	18"	42"
J42HB	23"	42"
J47HA	18"	47"
J47HB	23"	47"

Height • 84"

[hansonlab.com](http://hansonlab.com) • 805-498-3121

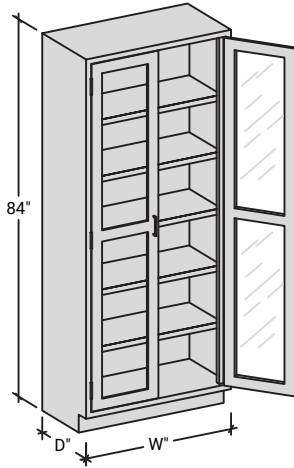

## Framed Glass Door - Tall Cabinets

- Inset steel - flush face construction
- Tall storage cabinets are 84" high - width and depth as shown below
- Tall cabinets have 5 adjustable shelves

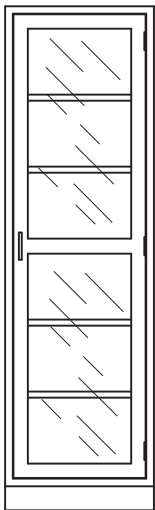

### Hinged Doors

Model	Depth	Width
K18HA	18"	18-3/4"
K18HB	23"	18-3/4"
K24HA	18"	24-3/4"
K24HB	23"	24-3/4"

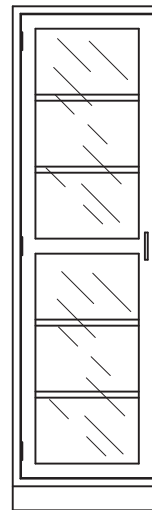

### Left Hinged Doors

Model	Depth	Width
K18HAL	18"	18-3/4"
K18HBL	23"	18-3/4"
K24HAL	18"	24-3/4"
K24HBL	23"	24-3/4"

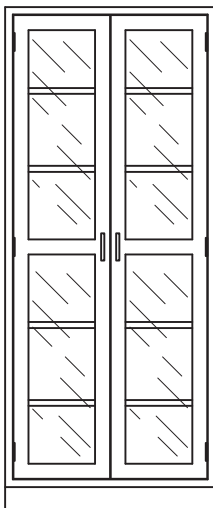

### Hinged Doors

Model	Depth	Width
L30HA	18"	30"
L30HB	23"	30"
L35HA	18"	35"
L35HB	23"	35"
L42HA	18"	42"
L42HB	23"	42"
L47HA	18"	47"
L47HB	23"	47"

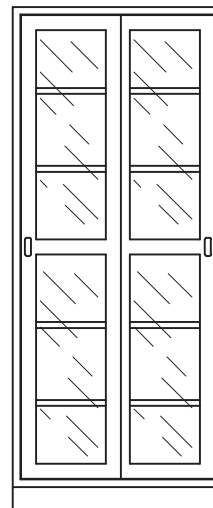

### Sliding Doors

Model	Depth	Width
M30HA	18"	30"
M30HB	23"	30"
M35HA	18"	35"
M35HB	23"	35"
M42HA	18"	42"
M42HB	23"	42"
M47HA	18"	47"
M47HB	23"	47"

# TALL STORAGE CABINETS

Height • 84"

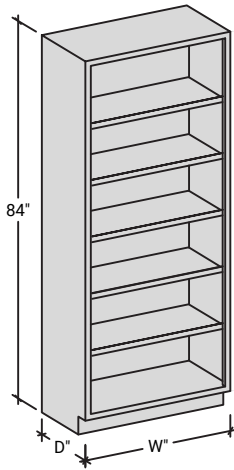

## Open - Tall Cabinets

- Inset steel - flush face construction.
- Tall storage cabinets are 84" high - width and depth as shown below
- Tall cabinets have 5 adjustable shelves

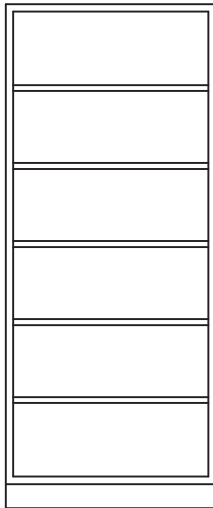

Model	Depth	Width
N18HA	18"	18-3/4"
N18HB	23"	18-3/4"
N24HA	18"	24-3/4"
N24HB	23"	24-3/4"
N30HA	18"	30"
N30HB	23"	30"
N35HA	18"	35"
N35HB	23"	35"
N42HA	18"	42"
N42HB	23"	42"
N47HA	18"	47"
N47HB	23"	47"



Height • 84"

[hansonlab.com](http://hansonlab.com) • 805-498-3121

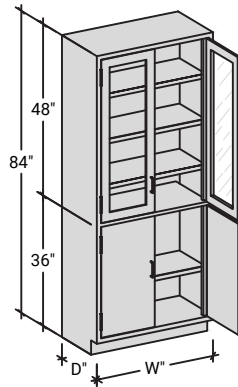

## Combination - Tall Cabinet

- Inset steel - flush face construction
- Tall storage cabinets are 84" high - width and depth as shown below
- Solid hinged door at bottom
- Top cabinet has (3) adjustable shelves, bottom cabinet has (1) adjustable shelf

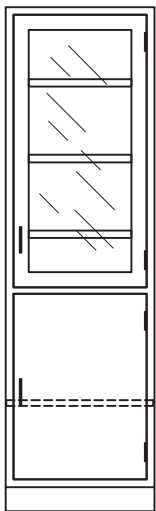

### Framed Glass Hinged Door at Top

Model	Depth	Width
O18HA	18"	18-3/4"
O18HB	23"	18-3/4"
O24HA	18"	24-3/4"
O24HB	23"	24-3/4"

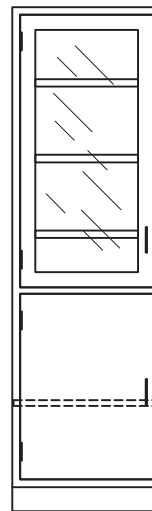

### Left Framed Glass Hinged Door at Top

Model	Depth	Width
O18HAL	18"	18-3/4"
O18HBL	23"	18-3/4"
O24HAL	18"	24-3/4"
O24HBL	23"	24-3/4"



### Framed Glass Hinged Doors at Top

Model	Depth	Width
O30HA	18"	30"
O30HB	23"	30"
O35HA	18"	35"
O35HB	23"	35"
O42HA	18"	42"
O42HB	23"	42"
O47HA	18"	47"
O47HB	23"	47"



### Framed Glass Sliding Doors at Top

Model	Depth	Width
P30HA	18"	30"
P30HB	23"	30"
P35HA	18"	35"
P35HB	23"	35"
P42HA	18"	42"
P42HB	23"	42"
P47HA	18"	47"
P47HB	23"	47"

# TALL STORAGE CABINETS

Height • 84"

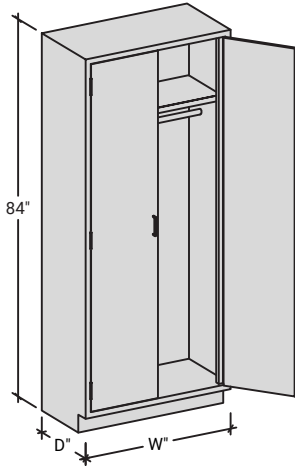

## Wardrobe - Tall Cabinets

- Inset steel - flush face construction
- Tall storage cabinets are 84" high - width and depth as shown below
- Top Shelf
- Clothes hanger rod
- Hinged solid door

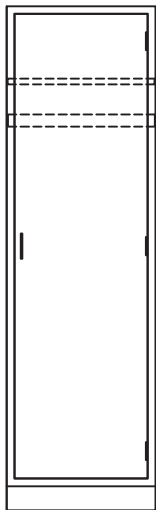

### Hinged Doors

Model	Depth	Width
Q18HB	23"	18-3/4"
Q24HB	23"	24-3/4"

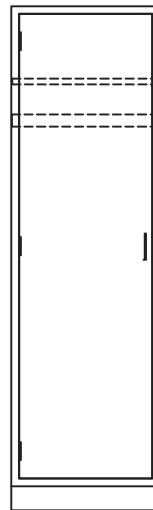

### Left Hinged Doors

Model	Depth	Width
Q18HBL	23"	18-3/4"
Q24HBL	23"	24-3/4"

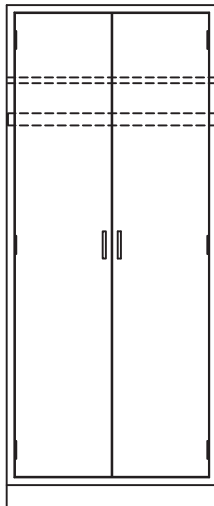

### Hinged Doors

Model	Depth	Width
Q30HB	23"	30"
Q35HB	23"	35"
Q42HB	23"	42"
Q47HB	23"	47"

### Tall Cabinet Front / End Filler

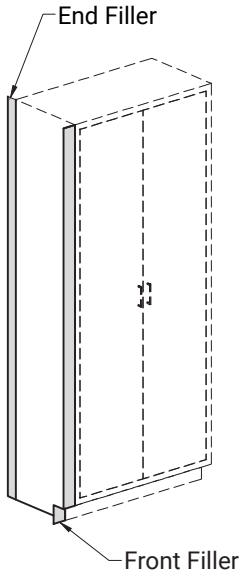

- Used between two cabinets or between a cabinet and a wall
- Specify -T if the panel needs to be field trimmed with an SA1TC double-slip angle

#### Front Filler

Model	Width	Height
TCF1	1"	84"
TCF3	3"	84"
TCF6	6"	84"
TCF12	12"	84"

#### End Filler

Model	Width	Height
TCEF1	1"	84"

#### Note:

TCF1 & TCEF1 are not trimmable.

### Tall Cabinet Finished Backs

- Finished back of tall cabinets
- Finished back panels are attached at the factory
- Add -FB to the end of the tall cabinet model number
- Tall cabinets must be properly anchored to walls or floors to prevent tipping

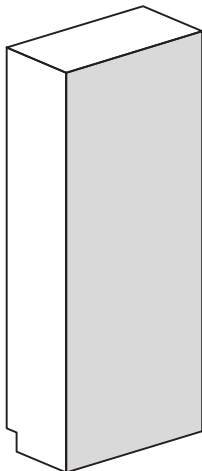

Model  
-FB

### Double-Slip Angle

- Used with tall cabinet when front filler panels need to be field trimmed

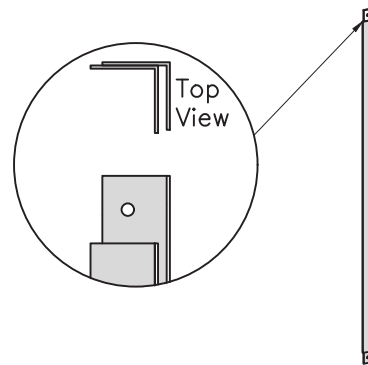

Model	Width	Height
SA1TC	1"	84"

# TALL CABINET ACCESSORIES

## Ceiling Enclosures & Sloping Tops

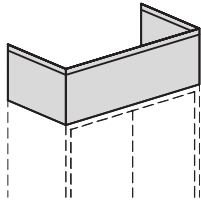

### Tall Cabinet Ceiling Enclosures

- Used to enclose the space between the top of the wall cabinet and the ceiling
- Angles for installation and trimmable scribes are provided
- A verified ceiling height is required to determine the correct enclosure height

### Sloping Tops

- Add -SL to the end of the tall cabinet model number

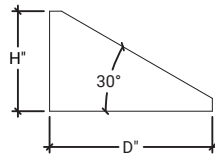
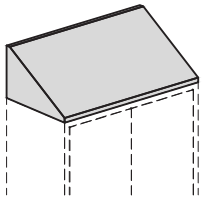

Model	Width	Depth	Height
A6810-18	18.75"	18"	11.064"
A6810-24	24.75"	18"	11.064"
A6810-30	30"	18"	11.064"
A6810-35	35"	18"	11.064"
A6810-42	42"	18"	11.064"
A6810-47	47"	18"	11.064"
A6820-18	18.75"	23"	13.951"
A6820-24	24.75"	23"	13.951"
A6820-30	30"	23"	13.951"
A6820-35	35"	23"	13.951"
A6820-42	42"	23"	13.951"
A6820-47	47"	23"	13.951"

### Corner Sloping Top

- Used in corners with sloping tops and where tall cabinets are at right angles

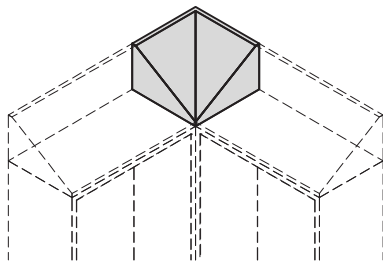

Model	Depth	Height
CSL18	18"	11.064"
CSL23	23"	13.951"

Model	Width	Depth	Height
CET1818-24	18.75"	18"	24"
CET1823-24	18.75"	23"	24"
CET2418-24	24.75"	18"	24"
CET2423-24	24.75"	23"	24"
CET3018-24	30"	18"	24"
CET3023-24	30"	23"	24"
CET3518-24	35"	18"	24"
CET3523-24	35"	23"	24"
CET4218-24	42"	18"	24"
CET4223-24	42"	23"	24"
CET4718-24	47"	18"	24"
CET4723-24	47"	23"	24"
CET1818-30	18.75"	18"	30"
CET1823-30	18.75"	23"	30"
CET2418-30	24.75"	18"	30"
CET2423-30	24.75"	23"	30"
CET3018-30	30"	18"	30"
CET3023-30	30"	23"	30"
CET3518-30	35"	18"	30"
CET3523-30	35"	23"	30"
CET4218-30	42"	18"	30"
CET4223-30	42"	23"	30"
CET4718-30	47"	18"	30"
CET4723-30	47"	23"	30"
CET1818-36	18.75"	18"	36"
CET1823-36	18.75"	23"	36"
CET2418-36	24.75"	18"	36"
CET2423-36	24.75"	23"	36"
CET3018-36	30"	18"	36"
CET3023-36	30"	23"	36"
CET3518-36	35"	18"	36"
CET3523-36	35"	23"	36"
CET4218-36	42"	18"	36"
CET4223-36	42"	23"	36"
CET4718-36	47"	18"	36"
CET4723-36	47"	23"	36"
CET1818-48	18.75"	18"	48"
CET1823-48	18.75"	23"	48"
CET2418-48	24.75"	18"	48"
CET2423-48	24.75"	23"	48"
CET3018-48	30"	18"	48"
CET3023-48	30"	23"	48"
CET3518-48	35"	18"	48"
CET3523-48	35"	23"	48"
CET4218-48	42"	18"	48"
CET4223-48	42"	23"	48"
CET4718-48	47"	18"	48"
CET4723-48	47"	23"	48"

Workstations and table options for every need, budget, and design solution.

AGILITY: Our premier bench with max load carrying capacity - features the HLS Service Hub option.

M-SERIES: 2 x 3" or 2 x 5" frame uprights; available with essential power and specialty gas services.

HDW: 2 x 2" welded construction; available with integrated shelving upright posts.

UTILITY: 2 x 2" knockdown design; optional bolt-on shelving upright posts.

HLS shelving and accessories are interchangeable within most HLS table families.



## Adaptable Furniture & Table Index

Page

<b>WORKSTATION / TABLE COMPARISON CHART</b> .....	70
<b>AGILITY WORKSTATIONS</b> .....	71
• Agility Mobile .....	71
• Agility Adaptable .....	72
• Agility Essential .....	73
• Agility Service Hub .....	75
• Agility Power, Gas and Data Options .....	78
<b>M-SERIES WORKSTATIONS</b> .....	79
• Features and Options .....	79
• Pre-Configured Bench Assemblies .....	81
• Worksurfaces & Suspended Cabinet Mount Kits .....	82
• M1/M2 Power Packs .....	83
• M3/M4 Power Packs .....	84
• M-Series Power, Gas, and Data Options .....	86
<b>HEAVY DUTY WELDED TABLES</b> .....	88
• Fixed Height .....	88
• Adjustable Height .....	94
<b>UTILITY TABLES</b> .....	97
• Utility Table Frames .....	97
• Utility Table Frame Accessories .....	98
<b>ACCESSORIES</b> .....	98
• Table Accessories .....	98
• Ceiling Service Panels and Couplers .....	101



# ADAPTABLE FURNITURE & TABLE COMPARISON CHART

	Utility	HDW	M-Series	Agility Essential	Agility Adaptable	Agility Mobile
<b>Description</b>	2x2, 14-ga knockdown construction w/ available add-on shelving upright posts	2x2, 14-ga fully-welded construction Available shelving upright posts. Suspended cabinet option.	2x3 (14-ga.) or 2x5 (11-ga.) integrated shelving upright posts. Suspended cabinet option.	2x5, 11-gauge construction w/ integrated shelving upright post available	2x5, 11-gauge construction w/ integrated shelving upright posts. Suspended cabinet option.	2x5, 11-gauge construction w/ integrated shelving upright post available
<b>Static Load Capacity*</b>	1200 lbs.	1200 lbs.	1200 lbs.	3000 lbs.	3000 lbs.	3000 lbs.
<b>Power, Data, Gas Services</b>	Bolt-on horizontal power strip available	Bolt-on horizontal power strip available	Post-integrated pre-wire, pre-plumb available	Full-range pre-wire, pre-plumbed services available w/ HLS Service Hub	Full-range pre-wire, pre-plumbed services available w/ HLS Service Hub	Full-range pre-wire, pre-plumbed services available w/ HLS Service Hub
<b>Mobility</b>	Available caster kit for light-duty applications	Available caster kit for light-duty applications	Modular design allows for expansion	Modular design allows for expansion	Moveable	Fully mobile – move your workstation with instrumentation intact
<b>Countertop Height</b>	Sitting, standing or adjustable height	Sitting, standing or adjustable height	6-position adjustable height	Multiple fixed heights available	6-position adjustable height	Fixed or adjustable height
<b>Widths (nominal)</b>	36", 48", 60", 72"	36", 48", 60", 72", 96"	36", 48", 60", 72"	36", 48", 60", 72"	36", 48", 60", 72", 96"	36", 48", 60", 72", 94"
<b>Depths (nominal)</b>	30, 36"	25", 30", 36", 42"	30", 36", 60" (double-sided)	30", 36", 60" (double-sided)	30", 36", 42", 60" (double-sided)	30", 36", 42"

\*weight evenly distributed, on leveling glides

**Work Surfaces:** Lab-grade phenolic, epoxy resin, plastic laminate, stainless steel (see page 127)

**Shelving:** Multiple depth choices with various retaining lip styles (see page 103)

## Agility Mobile Workstations

Agility Mobile workstations provide maximum flexibility to your room layout. Available with fixed or adjustable height countertop support, you can customize your workstation with a variety of accessories found on the next few pages to create the exact instrument cart or workstation you require.

- Thick-gauge knockdown design (-KD) welded steel frame supports 3000+ lb. capacity
- Heavy-duty locking casters and adjustable leveling feet provide superior stability
- Integrated adjustable-height shelving system for flexibility
- Configurable in multiple lengths, heights and depths
- Countertops heights are adjustable in 1" increments (Available on the adjustable height workstation)
- Assembly required

### Available options:

- Pre-wired / pre-plumbed Service Hub system offers numerous power, data and specialty gas services
- 1" thick lab-grade phenolic work surface (Epoxy or stainless also available)
- Upper shelving - multiples depth choices with various retaining lip styles
- Mobile cabinets - numerous door and drawer configurations
- Horizontal power strip
- Bin box mount

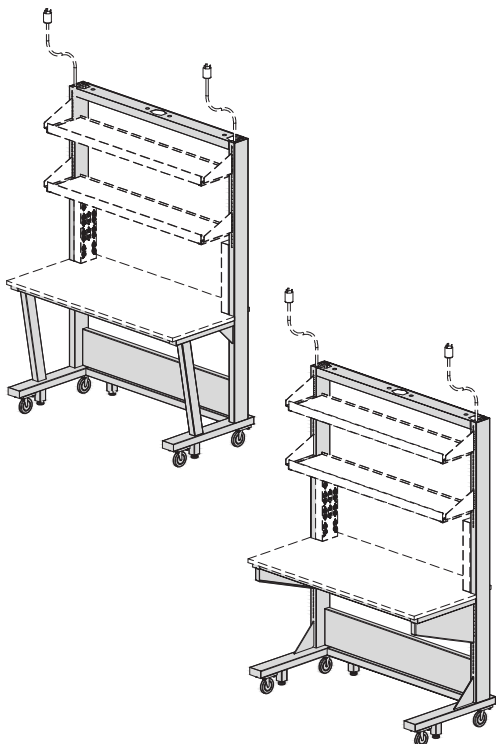

### Agility™ Mobile

Table system part numbering guide

## AM-60 30 H 84 R-KD

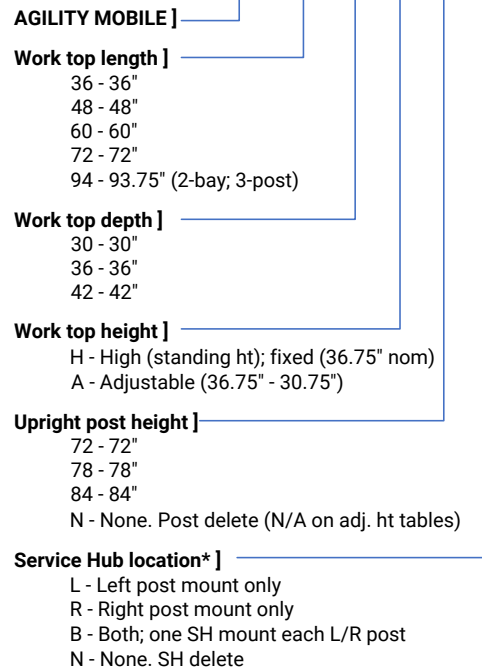

P/N example for 60"W x 30"D x 84"H, fixed-height bench with right-hand Service Hub:  
 AM-6030H84R-KD

\* 93.75" tables only  
 Use two letter indicators on 93.75" tables to identify Hub locations(s) - one letter per bay. First letter identifies LH bay configuration and second letter identifies RH bay configuration.

P/N example:  
 93.75"W x 30"D x 84"H fixed-height bench  
 LH bay: Service Hub on BOTH post faces  
 RH bay: Service Hub on LEFT post face only:  
 AM-9430H84BL-KD



# AGILITY ADAPTABLE WORKSTATIONS

## Agility Adaptable Workstations

- Adjustable work top height ( 6 position: 36.75" - 30.75")
- 11ga steel upright posts
- Knockdown design (assembly required)
- Static load capacity, equally distributed combined system: 3000 lbs
- Single or Double-sided configurations

### Available options:

- Pre-wired / pre-plumbed Service Hub system offers numerous power, data and specialty gas services
- 1" thick lab-grade phenolic work surface (Epoxy or stainless also available)
- Upper shelving - multiples depth choices with various retaining lip styles
- Mobile and suspended cabinets - numerous door and drawer configurations
- Horizontal power strip
- Bin box mount

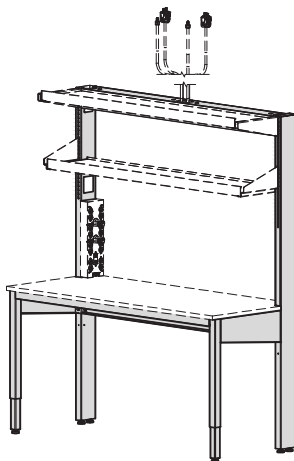

Single Sided Example

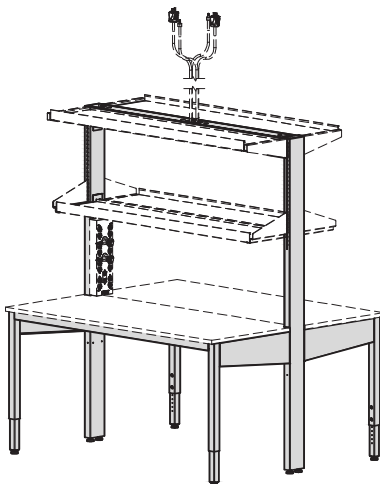

Double Sided Example

Agility™ Adaptable  
Table system part numbering guide

AA- 60 30 A 84 R SC

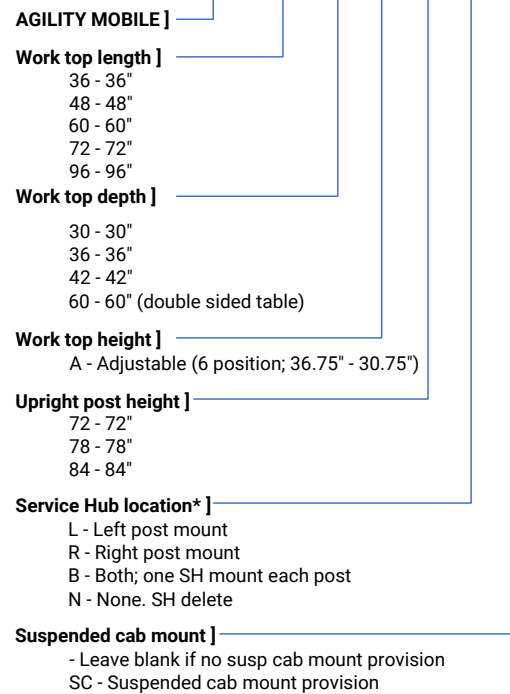

P/N example for 60"W x 30"D x 84"H, adjustable height bench with right-hand Service Hub:  
AA-6030A84R





## Agility Essential Workstations

- Multiple lengths, heights and depths available to meet your specifications
- 11ga steel upright posts
- Knockdown design (assembly required)
- Static load capacity, equally distributed combined system: 3000 lbs

### Available options:

- Pre-wired / pre-plumbed Service Hub system offers numerous power, data and specialty gas services
- 1" thick lab-grade phenolic work surface (Epoxy or stainless also available)
- Upper shelving - multiples depth choices with various retaining lip styles
- Mobile cabinets - numerous door and drawer configurations
- Horizontal power strip
- Bin box mount

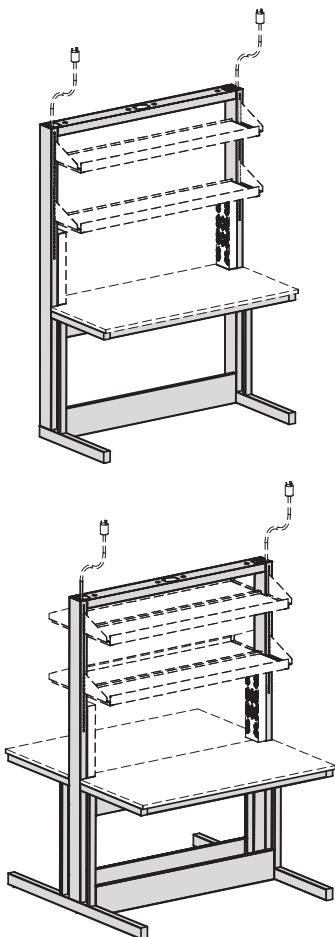

## Agility™ Essential Table system part numbering guide

**AE- 48 30 H 84 R**

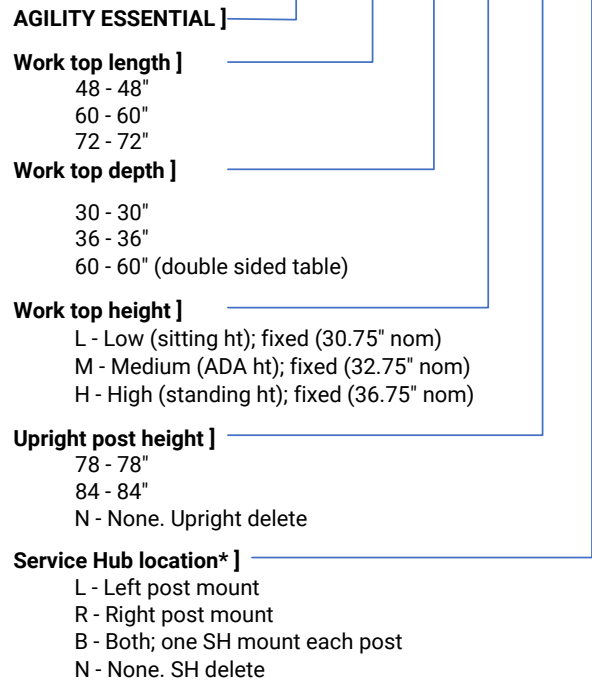

P/N example for 48"W x 30"D x 84"H, fixed-height (36.75 nom) bench with right-hand Service Hub:  
AE-4830H84R



# AGILITY ESSENTIAL DOUBLE ISLAND CLOSURE PANELS

## Double Island - End View

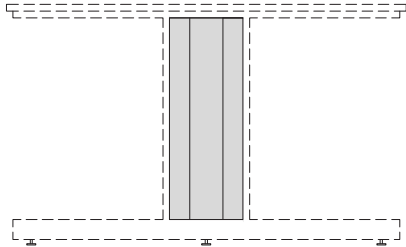

## Double Island - Front View

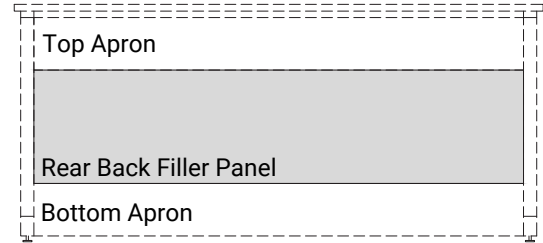

## End Filler Panels

- Used to completely close off the space between the leg supports of Agility Essential double island workstations

Model	Table Height
EFP25	29-3/4"
EFP31	35-3/4"

## Rear center Back Filler Panels

- Used to completely close off the back of each side of Agility Essential double island workstations
- Two panes required for double-sided island/benches

Model	Table Height	Table Width
RBP-L4-G2	29-3/4"	47-3/4"
RBP-L5-G2	29-3/4"	59-3/4"
RBP-L6-G2	29-3/4"	71-3/4"
RBP-A4-G2	32"	47-3/4"
RBP-A5-G2	32"	59-3/4"
RBP-A6-G2	32"	71-3/4"
RBP-H4-G2	35-3/4"	47-3/4"
RBP-H5-G2	35-3/4"	59-3/4"
RBP-H6-G2	35-3/4"	71-3/4"

### Agility Service Hub:

Service hubs are an addition that is unique to HLS Agility Workstations. Designed to be used on the Agility Mobile, Agility Adaptable and Agility Essential workstations. This exclusive design distributes power and services vertically for the most efficient use of the workspace.



Service Hub:  
Type 1



Service Hub:  
Type 2



Service Hub:  
Type 3

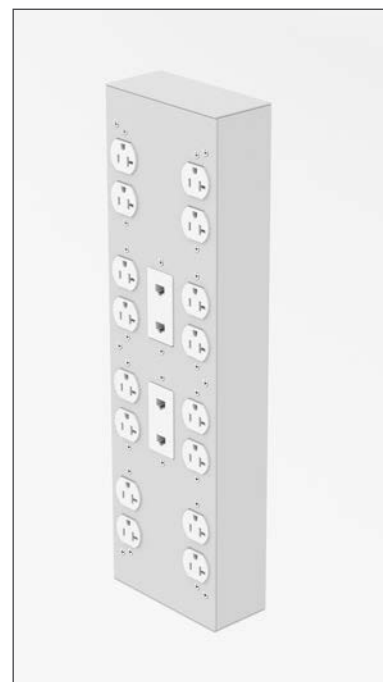

Service Hub:  
Type 4

# AGILITY ACCESSORIES

## Service Hubs

### Type 1 Service Hub - available options

C1 Detail	C2 Detail	C3 Detail	Power Input
N/A	Single 90° or Dual (180° opposed) needle valve turret*	N/A	N/A

### Type 2 Service Hub - available options

C1 Detail	C2 Detail	C3 Detail	Power Input
Up to four (4) 120v 20A duplexes**	Single 90° or Dual (180° opposed) needle valve turret*	RJ45 CAT 6 ethernet jack (specify quantity)	NEMA L5-20P or L14-20P supply power cord (specify power cord plug type)

\*Specify valve qty (1-3) and service type: Air, Vacuum, Argon, Nitrogen, CDA, CO2

\*\*Specify duplex color (white, red, orange, brown, grey), circuit count (1 or 2) - NOTE that each power circuit requires dedicated supply power cord and plug/receptacle. No more than one power type allowed per channel (ex: std power cannot be combined with emergency power in one channel)

Service Hub - Type 1

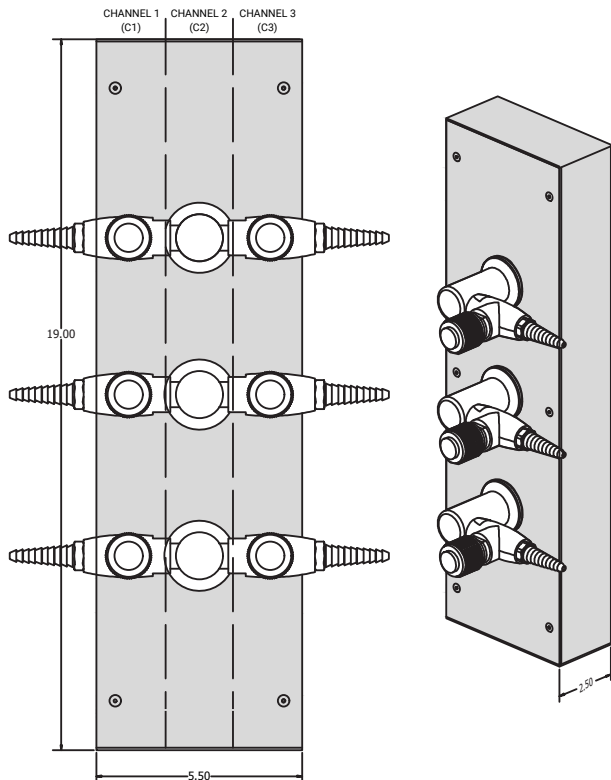

Service Hub - Type 2

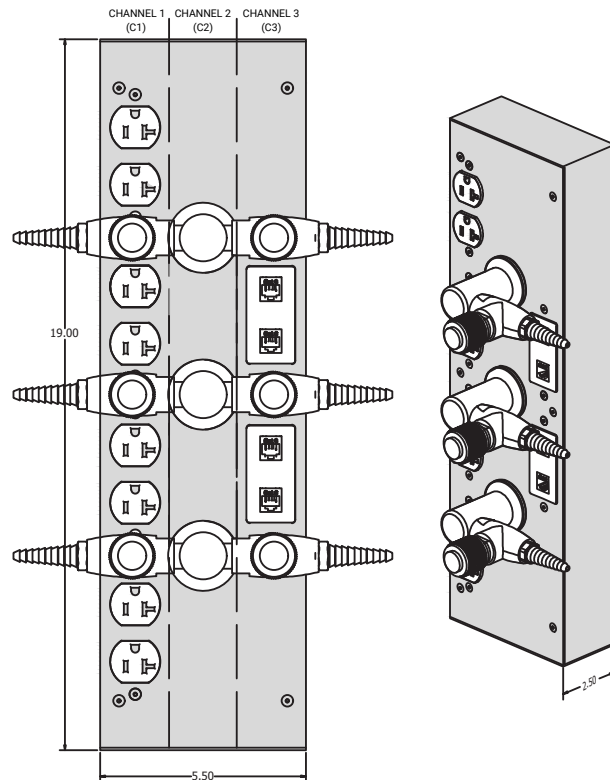

### Type 3 Service Hub - available options

C1 Detail	C2 Detail	C3 Detail	Power Input
Up to four (4) 120v 20A duplexes*	Single 90° or Dual (180° opposed) needle valve turret**	Up to four (4) 120v 20A duplexes*	NEMA L5-20P or L14-20P supply power cord (specify power cord plug type)

### Type 4 Service Hub - available options

C1 Detail	C2 Detail	C3 Detail	Power Input
Up to four (4) 120v 20A duplexes*	RJ45 CAT 6 ethernet jack (specify quantity)	Up to four (4) 120v 20A duplexes*	NEMA L5-20P or L14-20P supply power cord (specify power cord plug type)

\*Specify duplex color (white, red, orange, brown, grey), circuit count (1 or 2) - NOTE that each power circuit requires dedicated supply power cord and plug/receptacle. No more than one power type allowed per channel (ex: std power cannot be combined with emergency power in one channel)

\*\*Specify valve qty (1-2) and service type: Air, Vacuum, Argon, Nitrogen, CDA, CO2

### Service Hub - Type 3

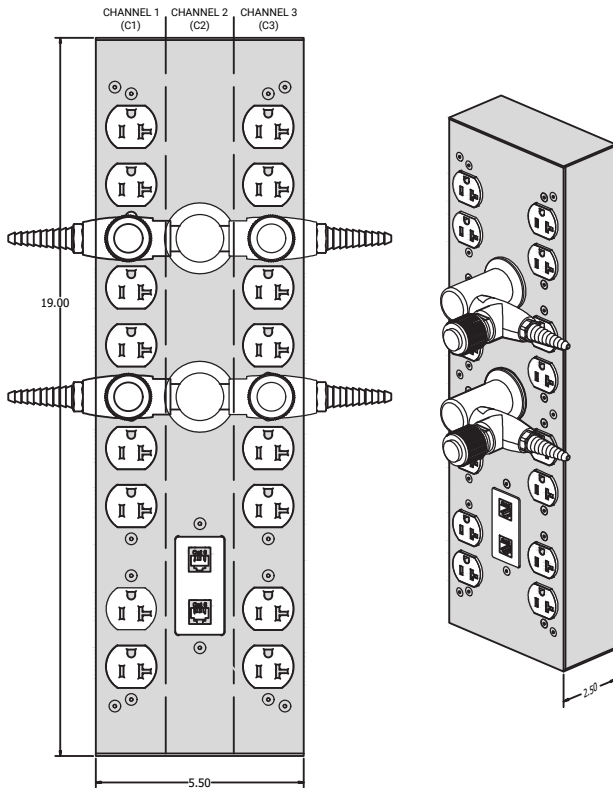

### Service Hub - Type 4

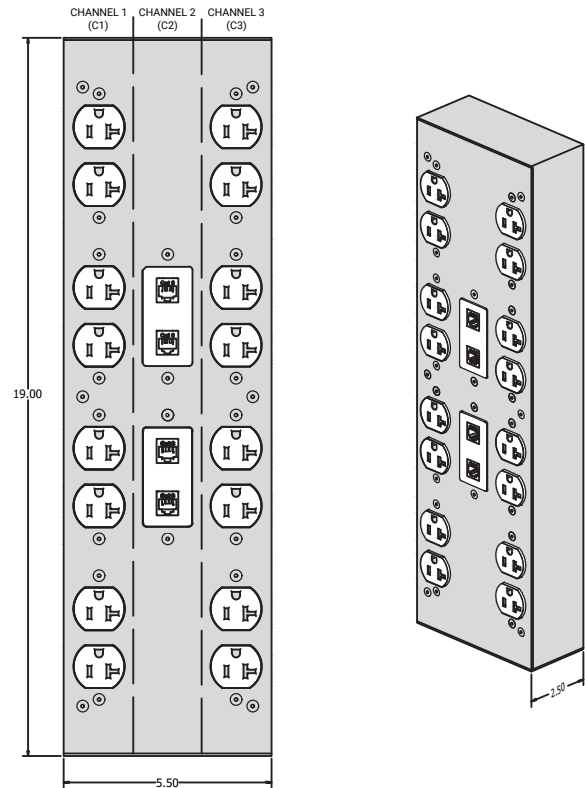

# AGILITY ACCESSORIES

## Service Hubs

### Needle Valve Turrets

- Each valve includes one (1) pre-plumbed gas hose and hose end per valve
- Specify gas service valve qty (1-3) and service type (Air, Vacuum, Argon, Nitrogen, CDA, CO2)
- Hoses extend out the top of post

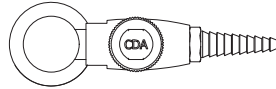
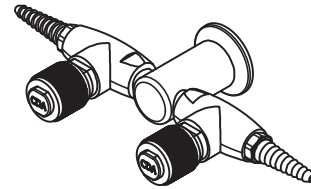
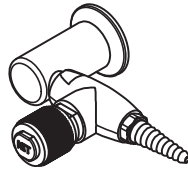

90° Valve

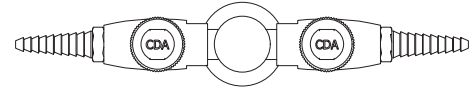

180° Valve

### 120V 20A power (specify color)

- Pre-wired 120VAC 20A duplex
- Includes single 12AWG 3C power cable per circuit with L5-20P plug extending out the top of the post
- Specify duplex color (white, red, orange, brown, grey) and qty (1-4)

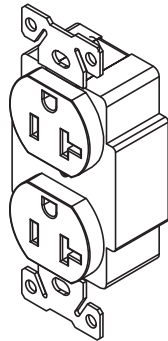

### 208/220V power (specify type)

- Pre-wired 208VAC L6-20R receptacle
- Includes 12AWG 3C power cable with L6-20P plug extending out the top of the post

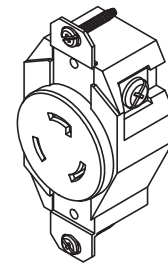

### RJ45 data

- Includes prewired RJ45 data jacks (specify quantity)
- Cables extend out the top of post

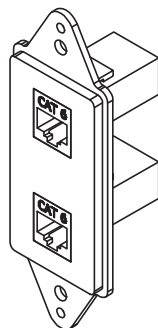

## M-Series Bench Systems

- HLS M-series bench systems are highly configurable, and offer numerous accessory options designed to meet a variety of project budgets
- This new line of benches has been engineered with features to meet your load and usage demands, including knock-down design for economical transportation
- Power, data, and gas service options can be pre-installed into the frame, resulting in a clean, uncompromised work center
- Services can be upgraded or re-configured in the field with minimal effort

## Bench Configurations:

- M1 - Single-sided, 2x3" 14GA upright post
- M2 - Double-sided, 2x3" 14GA upright post
- M3 - Single-sided, 2x5" 11GA upright post
- M4 - Double-sided, 2x5" 11GA upright post

## Sizing choices

- Widths - 3', 4', 5', 6'
- Depths - 30", 36", 60" (double-sided)

## Included features

- Six-position adjustable work top height (1" increments from 30-3/4 to 36-3/4")
- Knockdown design (assembly required)
- 14 or 11-gauge steel tube construction typical
- Durable powdercoat finish
- 84" tall upright posts
- Accessory port covers allow future upgrades as needed
- Static load capacity, equally distributed combined system: 1200 lbs (SEFA category 4)

## Available options:

- Pre-wired / pre-plumbed power, data and specialty gas integration in vertical posts
- 1" thick lab-grade phenolic work surface (Epoxy or stainless also available)
- Upper shelving - multiple depth choices with various retaining lip styles
- Mobile and suspended cabinets - numerous door and drawer configurations
- Horizontal power strip
- Bin box mount

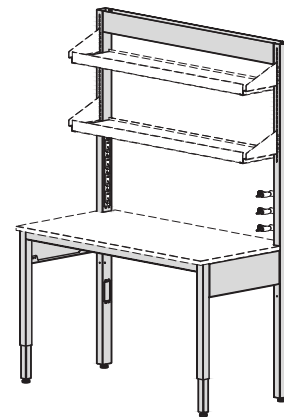

M1 - (shown w/ accessories)

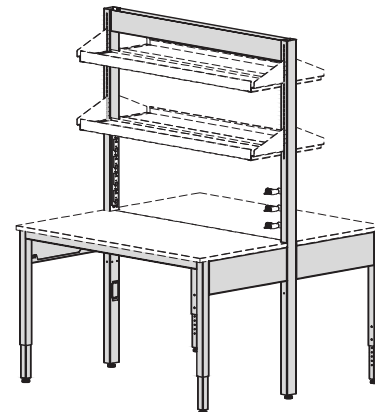

M2 - (shown w/ accessories)



# M-SERIES WORKSTATIONS

## M-Series Bench system part numbering guide

**M3 - 60 30 H-2P**

### Bench configurations ]

- M1 - Single-sided, 2x3"
- M2 - Double-sided, 2x3"
- M3 - Single-sided, 2x5"
- M4 - Double-sided, 2x5"

### Work top length ]

- 36 - 36"
- 48 - 48"
- 60 - 60"
- 72 - 72"

### Work top depth ]

- 30 - 30" (M1 and M3)
- 36 - 36" (M1 and M3)
- 60 - 60" (M2 and M4)

### Upright post height ]

- H - 84"

### Optional features ]

- 1P - 1-post power
- 2P - 2-post power
- 1G2D - 1-gas + 2-data in one post
- 2G2D - 2-gas + 2-data in one post
- 3G2D - 3-gas + 2-data in one post
- 1P1G2D - 1-post power, 1-gas + 2-data other post
- 1P2G2D - 1-post power, 2-gas + 2-data other post
- 1P3G2D - 1-post power, 3-gas + 2-data other pos

\* if no optional features are required, leave part number suffix blank

P/N example for 60"W x 30" M3 frame, with power in both upright posts: M3-6030H-2P

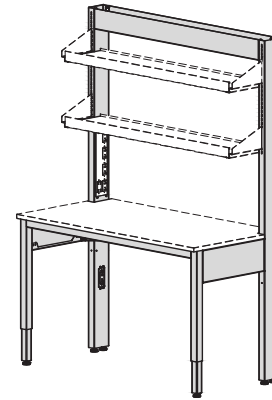

M3 - (shown w/ accessories)

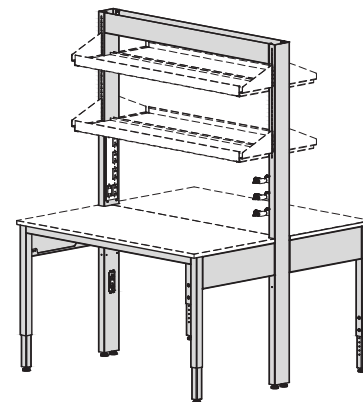

M4 - (shown w/ accessories)

### Application notes-

M1 & M2: Max. five duplexes per power cord; Max one power cord/circuit per post

M3 & M4: Max. five duplexes per cord; Max two power cords/circuits per post





Part Number	Description	Frame Width	Frame Depth	Top Size (not included)	Frame configuration
<b>M1-6030H-1P1G2D</b>	BENCH FRAME ASY, SINGLE, M1, 60W x 30 X 84H, 2X3, 1-POST PWR, 1-GAS + 2-DATA, NO TOP	59-3/4"	28"	60" x 30"	Single-side
<b>M1-6030H-1P2G2D</b>	BENCH FRAME ASY, SINGLE, M1, 60W x 30 X 84H, 2X3, 1-POST PWR, 2-GAS + 2-DATA, NO TOP	59-3/4"	28"	60" x 30"	Single-side
<b>M1-6030H-1P3G2D</b>	BENCH FRAME ASY, SINGLE, M1, 60W x 30 X 84H, 2X3, 1-POST PWR, 3-GAS + 2-DATA, NO TOP	59-3/4"	28"	60" x 30"	Single-side
<b>M1-7230H-1P1G2D</b>	BENCH FRAME ASY, SINGLE, M1, 72W x 30 X 84H, 2X3, 1-POST PWR, 1-GAS + 2-DATA, NO TOP	71-3/4"	28"	72" x 30"	Single-side
<b>M1-7230H-1P2G2D</b>	BENCH FRAME ASY, SINGLE, M1, 72W x 30 X 84H, 2X3, 1-POST PWR, 2-GAS + 2-DATA, NO TOP	71-3/4"	28"	72" x 30"	Single-side
<b>M1-7230H-1P3G2D</b>	BENCH FRAME ASY, SINGLE, M1, 72W x 30 X 84H, 2X3, 1-POST PWR, 3-GAS + 2-DATA, NO TOP	71-3/4"	28"	72" X 30"	Single-side
<b>M2-6060H-1P1G2D</b>	BENCH FRAME ASY, DOUBLE, M2, 60W x 60 X 84H, 2X3, 1-POST PWR, 1-GAS + 2-DATA, NO TOP	59-3/4"	58"	60" x 60" (2 piece top)	Double-side
<b>M2-6060H-1P2G2D</b>	BENCH FRAME ASY, DOUBLE, M2, 60W x 60 X 84H, 2X3, 1-POST PWR, 2-GAS + 2-DATA, NO TOP	59-3/4"	58"	60" x 60" (2 piece top)	Double-side
<b>M2-6060H-1P3G2D</b>	BENCH FRAME ASY, DOUBLE, M2, 60W x 60 X 84H, 2X3, 1-POST PWR, 3-GAS + 2-DATA, NO TOP	59-3/4"	58"	60" x 60" (2 piece top)	Double-side
<b>M2-7260H-1P1G2D</b>	BENCH FRAME ASY, DOUBLE, M2, 72W x 60 X 84H, 2X3, 1-POST PWR, 1-GAS + 2-DATA, NO TOP	71-3/4"	58"	72" x 60" (2 piece top)	Double-side
<b>M2-7260H-1P2G2D</b>	BENCH FRAME ASY, DOUBLE, M2, 72W x 60 X 84H, 2X3, 1-POST PWR, 2-GAS + 2-DATA, NO TOP	71-3/4"	58"	72" x 60" (2 piece top)	Double-side
<b>M2-7260H-1P3G2D</b>	BENCH FRAME ASY, DOUBLE, M2, 72W x 60 X 84H, 2X3, 1-POST PWR, 3-GAS + 2-DATA, NO TOP	71-3/4"	58"	72" x 60" (2 piece top)	Double-side

NOTE: specify gas service type(s) at time of order.

### Work surfaces; M-Series (Science-grade black phenolic, 1" thick)

Part Number	Description
CTOP-PHENM13630-1.0IN	COUNTERTOP, PHENOLIC, M1 36x30 BLACK, FIN EDGES, 1" THK, EACH
CTOP-PHENM14830-1.0IN	COUNTERTOP, PHENOLIC, M1 48x30 BLACK, FIN EDGES, 1" THK, EACH
CTOP-PHENM16030-1.0IN	COUNTERTOP, PHENOLIC, M1 60x30 BLACK, FIN EDGES, 1" THK, EACH
CTOP-PHENM17230-1.0IN	COUNTERTOP, PHENOLIC, M1 72x30 BLACK, FIN EDGES, 1" THK, EACH
CTOP-PHENM236DS-1.0IN	COUNTERTOP, PHENOLIC, M2 36x30 DS BLACK, FIN EDGES, 1" THK, EA (2 REQ'D)
CTOP-PHENM248DS-1.0IN	COUNTERTOP, PHENOLIC, M2 48x30 DS BLACK, FIN EDGES, 1" THK, EA (2 REQ'D)
CTOP-PHENM260DS-1.0IN	COUNTERTOP, PHENOLIC, M2 60x30 DS BLACK, FIN EDGES, 1" THK, EA (2 REQ'D)
CTOP-PHENM272DS-1.0IN	COUNTERTOP, PHENOLIC, M2 72x30 DS BLACK, FIN EDGES, 1" THK, EA (2 REQ'D)
CTOP-PHENAA3630-1.0IN	COUNTERTOP, PHENOLIC, AA/AE/M3 36x30 BLACK, FIN EDGES, 1" THK, EACH
CTOP-PHENAA4830-1.0IN	COUNTERTOP, PHENOLIC, AA/AE/M3 48x30 BLACK, FIN EDGES, 1" THK, EACH
CTOP-PHENAA6030-1.0IN	COUNTERTOP, PHENOLIC, AA/AE/M3 60x30 BLACK, FIN EDGES, 1" THK, EACH
CTOP-PHENAA7230-1.0IN	COUNTERTOP, PHENOLIC, AA/AE/M3 72x30 BLACK, FIN EDGES, 1" THK, EACH
CTOP-PHENAA36DS-1.0IN	COUNTERTOP, PHENOLIC, AA/AE/M4 36x30 DS BLACK, FIN EDGES, 1" THK, EA (2 REQ'D)
CTOP-PHENAA48DS-1.0IN	COUNTERTOP, PHENOLIC, AA/AE/M4 48x30 DS BLACK, FIN EDGES, 1" THK, EA (2 REQ'D)
CTOP-PHENAA60DS-1.0IN	COUNTERTOP, PHENOLIC, AA/AE/M4 60x30 DS BLACK, FIN EDGES, 1" THK, EA (2 REQ'D)
CTOP-PHENAA72DS-1.0IN	COUNTERTOP, PHENOLIC, AA/AE/M4 72x30 DS BLACK, FIN EDGES, 1" THK, EA (2 REQ'D)

### Suspended Cabinet Mount Kit

(see catalog page 29 for compatible HLS suspended cabinets)

Part Number	Description
K13429-36	MOUNT RAIL KIT, SUSP CAB, 36W, M-SERIES BENCH
K13429-48	MOUNT RAIL KIT, SUSP CAB, 48W, M-SERIES BENCH
K13429-60	MOUNT RAIL KIT, SUSP CAB, 60W, M-SERIES BENCH
K13429-72	MOUNT RAIL KIT, SUSP CAB, 72W, M-SERIES BENCH

### M1/M2 Applications

Style 1A	Style 2A	Style 3A
<p>Pre-wired 120VAC 20A duplexes on single circuit. Includes single 12AWG 3C power cable with L5-20P plug extending out the top of the post. Specify duplex color (white, red, orange, brown, grey) and qty (1-4)</p>	<p>Includes one (1) pre-plumbed gas hose and hose end per valve. Specify gas service valve qty (1-3), service type (Air, Vacuum, Argon, Nitrogen, CDA, CO2), and single (90°) or dual (180°) outlet valve(s). Includes two (2) pre-wired RJ45 ethernet jacks. Hose and data cable extend out the top of post.</p>	<p>Pre-wired 208VAC L6-20R receptacle. Includes 12AWG 3C power cable with L6-20P plug extending out the top of the post.</p>



STYLE 1A

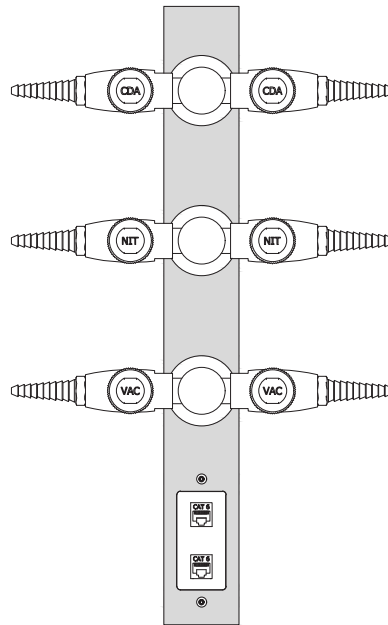

STYLE 2A



STYLE 3A



# M-SERIES

## M3/M4 Power Packs

### M3/M4 Applications

Style 1B	Style 2B	Style 3B	Style 4B	Style 5B
<p>Pre-wired 120VAC 20A duplexes on single circuit. Includes single 12AWG 3C power cable with L5-20P plug extending out the top of the post. Specify duplex color (white, red, orange, brown, grey) and qty (1-4). Two circuits (2 cords) may be available*.</p>	<p>Includes one (1) pre-plumbed gas hose and hose end per valve. Specify gas service valve qty (1-3), service type (Air, Vacuum, Argon, Nitrogen, CDA, CO2), and single (90°) or dual (180°) outlet valve(s). Includes four (4) pre-wired RJ45 ethernet jacks. Hose and data cable extend out the top of post.</p>	<p>Pre-wired 208VAC L6-20R receptacle. Includes 12AWG 3C power cable with L6-20P plug extending out the top of the post.</p>	<p>Pre-wired 120VAC 20A duplexes on single circuit. Includes single 12AWG 3C power cable with L5-20P plug extending out the top of the post. Specify duplex color (white, red, orange, brown, grey) and qty (1-4). Two circuits (2 cords) may be available*. Single 4-port USB power duplex. Integrated 24v 60W power w/ 5.5mm jack for LED undershelf light.</p>	<p>Pre-wired 120VAC 20A duplexes. Includes 12AWG 3C power cable(s) with L5-20P plug(s) extending out the top of the post. Specify duplex color (white, red, orange, brown, grey) and qty (5-8). Two circuits (2 cords) may be available*.</p>

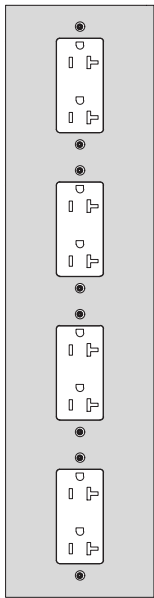

STYLE 1B

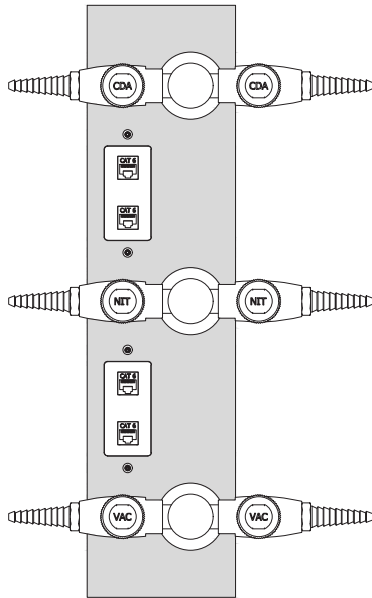

STYLE 2B



STYLE 3B

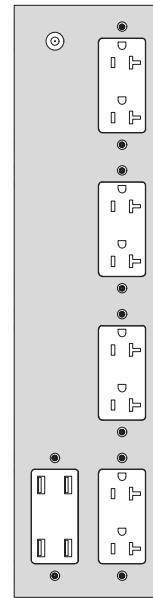

STYLE 4B

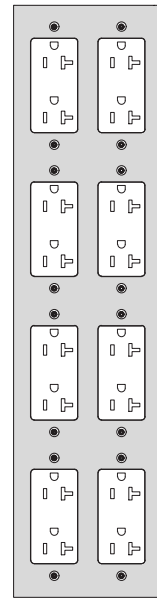

STYLE 5B

\* Contact your HLS Sales representative for more details



STYLE 1B



STYLE 2B



STYLE 3B



STYLE 4B



STYLE 5B

# M-SERIES

## Power, Gas and Data Options

### Needle Valve Turrets

- Each valve includes one (1) pre-plumbed gas hose and hose end per valve
- Specify gas service valve qty (1-3) and service type (Air, Vacuum, Argon, Nitrogen, CDA, CO2)
- Hoses extend out the top of post

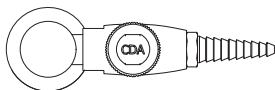
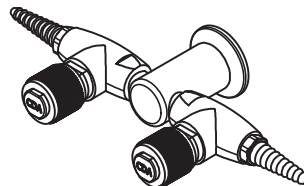
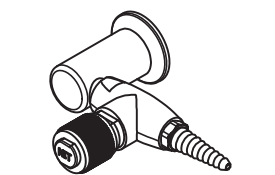

90° Valve

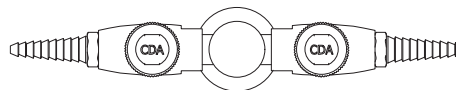

180° Valve

### 120V 20A power (specify color)

- Pre-wired 120VAC 20A duplexes
- Includes single 12AWG 3C power cable per circuit with L5-20P plug extending out the top of the post
- Specify duplex color (white, red, orange, brown, grey) and qty (1-4)

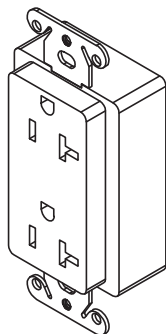

### 208/220V power (specify type)

- Pre-wired 208VAC L6-20R receptacle
- Includes 12AWG 3C power cable with L6-20P plug extending out the top of the post

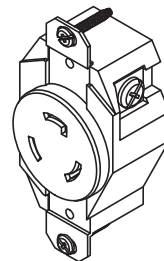

### RJ45 data

- Includes prewired RJ45 data jacks (specify quantity)
- Cables extend out the top of post

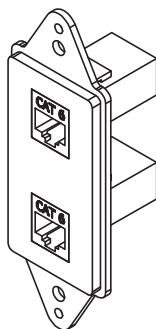



M1 / M2



M1 / M2



M3 / M4

# TABLES – HEAVY DUTY WELDED

## Fixed Height

- Heavy Duty welded construction, complete with leveling glides
- Tables can be used with a bottom shelf, or mobile cabinet
- Countertop overhangs side edges of table frames by 1/8", 1" overhang at front and rear of frame is typical
- Countertop, brackets, shelves, and cabinets must be ordered separately
- Shipped fully assembled, except for shelves, countertop, or accessories

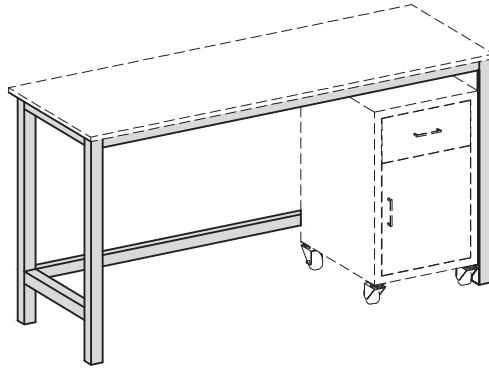

### Heavy Duty Welded Tables, 29-3/4" High

Model	Frame Width	Frame Depth	Top Size
HDW36A29-G2	35-3/4"	23"	36" x 25"
HDW48A29-G2	47-3/4"	23"	48" x 25"
HDW60A29-G2	59-3/4"	23"	60" x 25"
HDW72A29-G2	71-3/4"	23"	72" x 25"
HDW36B29-G2	35-3/4"	28"	36" x 30"
HDW48B29-G2	47-3/4"	28"	48" X 30"
HDW60B29-G2	59-3/4"	28"	60" X 30"
HDW72B29-G2	71-3/4"	28"	72" X 30"
HDW36C29-G2	35-3/4"	34"	36" X 36"
HDW48C29-G2	47-3/4"	34"	48" X 36"
HDW60C29-G2	59-3/4"	34"	60" X 36"
HDW72C29-G2	71-3/4"	34"	72" X 36"
HDW36D29-G2	35-3/4"	40"	36" X 42"
HDW48D29-G2	47-3/4"	40"	48" x 42"
HDW60D29-G2	59-3/4"	40"	60" x 42"
HDW72D29-G2	71-3/4"	40"	72" x 42"

### Heavy Duty Welded Tables, 35-3/4" High

Model	Frame Width	Frame Depth	Top Size
HDW36A35-G2	35-3/4"	23"	36" x 25"
HDW48A35-G2	47-3/4"	23"	48" x 25"
HDW60A35-G2	59-3/4"	23"	60" x 25"
HDW72A35-G2	71-3/4"	23"	72" x 25"
HDW36B35-G2	35-3/4"	28"	36" x 30"
HDW48B35-G2	47-3/4"	28"	48" X 30"
HDW60B35-G2	59-3/4"	28"	60" X 30"
HDW72B35-G2	71-3/4"	28"	72" X 30"
HDW36C35-G2	35-3/4"	34"	36" X 36"
HDW48C35-G2	47-3/4"	34"	48" X 36"
HDW60C35-G2	59-3/4"	34"	60" X 36"
HDW72C35-G2	71-3/4"	34"	72" X 36"
HDW36D35-G2	35-3/4"	40"	36" X 42"
HDW48D35-G2	47-3/4"	40"	48" x 42"
HDW60D35-G2	59-3/4"	40"	60" x 42"
HDW72D35-G2	71-3/4"	40"	72" x 42"



## Fixed Height w/ Uprights

[hansonlab.com](http://hansonlab.com) • 805-498-3121

- Heavy Duty welded construction, complete with leveling glides
- Tables can be used with a bottom shelf, suspended or mobile cabinet
- Countertop overhangs side edges of table frames by 1/8", 1" overhang at front and rear of frame is typical
- Countertop, brackets, shelves, and cabinets must be ordered separately
- Shipped fully assembled, except for shelves, countertop, or accessories
- Total Height 78" to top of upright posts
- Rear upright posts are 2" wide by 2" deep

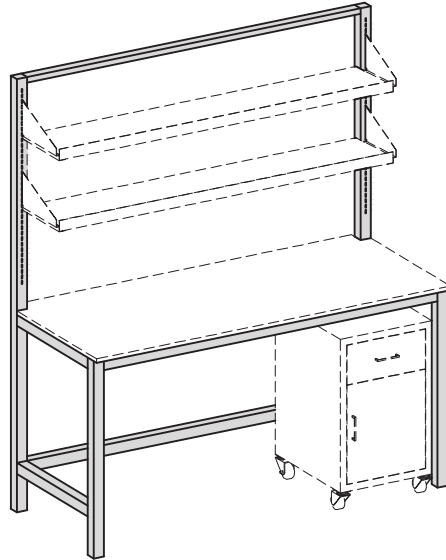

### Heavy Duty Welded Tables, 29-3/4" High w/ Shelf Upright posts

Model	Frame Width	Frame Depth	Top Size
HDWU36A29-G2	35-3/4"	23"	36" x 25"
HDWU48A29-G2	47-3/4"	23"	48" x 25"
HDWU60A29-G2	59-3/4"	23"	60" x 25"
HDWU72A29-G2	71-3/4"	23"	72" x 25"
HDWU36B29-G2	35-3/4"	28"	36" x 30"
HDWU48B29-G2	47-3/4"	28"	48" X 30"
HDWU60B29-G2	59-3/4"	28"	60" X 30"
HDWU72B29-G2	71-3/4"	28"	72" X 30"
HDWU36C29-G2	35-3/4"	34"	36" X 36"
HDWU48C29-G2	47-3/4"	34"	48" X 36"
HDWU60C29-G2	59-3/4"	34"	60" X 36"
HDWU72C29-G2	71-3/4"	34"	72" X 36"
HDWU36D29-G2	35-3/4"	40"	36" X 42"
HDWU48D29-G2	47-3/4"	40"	48" x 42"
HDWU60D29-G2	59-3/4"	40"	60" x 42"
HDWU72D29-G2	71-3/4"	40"	72" x 42"

### Heavy Duty Welded Tables, 35-3/4" High w/ Shelf Upright posts

Model	Frame Width	Frame Depth	Top Size
HDWU36A35-G2	35-3/4"	23"	36" x 25"
HDWU48A35-G2	47-3/4"	23"	48" x 25"
HDWU60A35-G2	59-3/4"	23"	60" x 25"
HDWU72A35-G2	71-3/4"	23"	72" x 25"
HDWU36B35-G2	35-3/4"	28"	36" x 30"
HDWU48B35-G2	47-3/4"	28"	48" X 30"
HDWU60B35-G2	59-3/4"	28"	60" X 30"
HDWU72B35-G2	71-3/4"	28"	72" X 30"
HDWU36C35-G2	35-3/4"	34"	36" X 36"
HDWU48C35-G2	47-3/4"	34"	48" X 36"
HDWU60C35-G2	59-3/4"	34"	60" X 36"
HDWU72C35-G2	71-3/4"	34"	72" X 36"
HDWU36D35-G2	35-3/4"	40"	36" X 42"
HDWU48D35-G2	47-3/4"	40"	48" x 42"
HDWU60D35-G2	59-3/4"	40"	60" x 42"
HDWU72D35-G2	71-3/4"	40"	72" x 42"

# TABLES – HEAVY DUTY WELDED

## Fixed Height w/ Suspended Cabinet Mount

- Heavy Duty welded construction, complete with leveling glides
- Countertops overhang side edges of table frames by 1/8", 1" overhang at front and rear of frame is typical
- Countertop, and cabinets must be ordered separately
- Shipped fully assembled, except for cabinets, countertop, or accessories

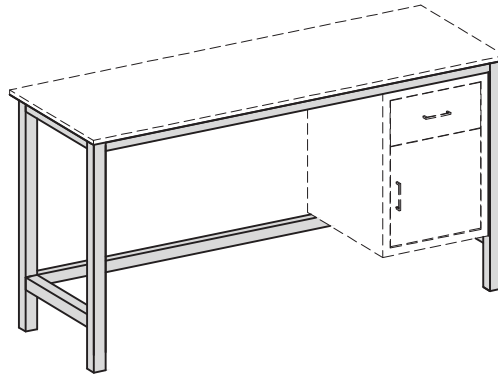

### Heavy Duty Welded Tables, 29-3/4" High w/ Shelf Upright Posts & Suspended Cabinet Compatibility

Model	Frame Width	Frame Depth	Top Size
HDW36A29SC-G2	35-3/4"	23"	36" x 25"
HDW48A29SC-G2	47-3/4"	23"	48" x 25"
HDW60A29SC-G2	59-3/4"	23"	60" x 25"
HDW72A29SC-G2	71-3/4"	23"	72" x 25"
HDW36B29SC-G2	35-3/4"	28"	36" x 30"
HDW48B29SC-G2	47-3/4"	28"	48" X 30"
HDW60B29SC-G2	59-3/4"	28"	60" X 30"
HDW72B29SC-G2	71-3/4"	28"	72" X 30"
HDW36C29SC-G2	35-3/4"	34"	36" X 36"
HDW48C29SC-G2	47-3/4"	34"	48" X 36"
HDW60C29SC-G2	59-3/4"	34"	60" X 36"
HDW72C29SC-G2	71-3/4"	34"	72" X 36"
HDW36D29SC-G2	35-3/4"	40"	36" X 42"
HDW48D29SC-G2	47-3/4"	40"	48" x 42"
HDW60D29SC-G2	59-3/4"	40"	60" x 42"
HDW72D29SC-G2	71-3/4"	40"	72" x 42"

### Heavy Duty Welded Tables, 35-3/4" High w/ Shelf Upright Posts & Suspended Cabinet Compatibility

Model	Frame Width	Frame Depth	Top Size
HDW36A35SC-G2	35-3/4"	23"	36" x 25"
HDW48A35SC-G2	47-3/4"	23"	48" x 25"
HDW60A35SC-G2	59-3/4"	23"	60" x 25"
HDW72A35SC-G2	71-3/4"	23"	72" x 25"
HDW36B35SC-G2	35-3/4"	28"	36" x 30"
HDW48B35SC-G2	47-3/4"	28"	48" X 30"
HDW60B35SC-G2	59-3/4"	28"	60" X 30"
HDW72B35SC-G2	71-3/4"	28"	72" X 30"
HDW36C35SC-G2	35-3/4"	34"	36" X 36"
HDW48C35SC-G2	47-3/4"	34"	48" X 36"
HDW60C35SC-G2	59-3/4"	34"	60" X 36"
HDW72C35SC-G2	71-3/4"	34"	72" X 36"
HDW36D35SC-G2	35-3/4"	40"	36" X 42"
HDW48D35SC-G2	47-3/4"	40"	48" x 42"
HDW60D35SC-G2	59-3/4"	40"	60" x 42"
HDW72D35SC-G2	71-3/4"	40"	72" x 42"

## Fixed Height w/ Upright Posts & Suspended Cabinet Mount

[hansonlab.com](http://hansonlab.com) • 805-498-3121

- Heavy Duty welded construction, complete with leveling glides
- Countertops overhang side edges of table frames by 1/8", 1" overhang at front and rear of frame is typical
- Countertop, and cabinets must be ordered separately
- Shipped fully assembled, except for cabinets, countertop, or accessories
- Total Height 78" to top of upright posts
- Rear upright posts are 2" wide by 2" deep

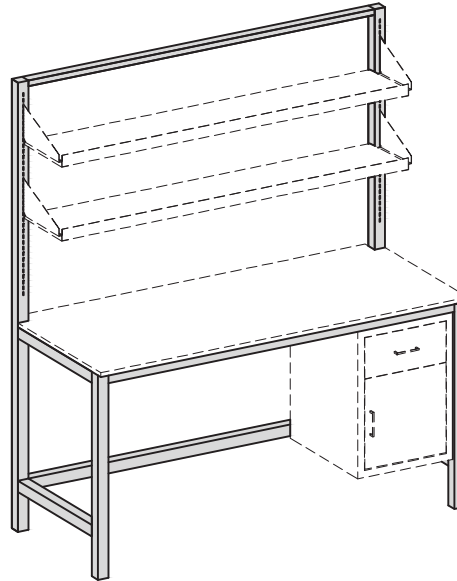

### Heavy Duty Welded Tables, 29-3/4" High w/ Shelf Upright Posts & Suspended Cabinet Compatibility

Model	Frame Width	Frame Depth	Top Size
HDWU36A29SC-G2	35-3/4"	23"	36" x 25"
HDWU48A29SC-G2	47-3/4"	23"	48" x 25"
HDWU60A29SC-G2	59-3/4"	23"	60" x 25"
HDWU72A29SC-G2	71-3/4"	23"	72" x 25"
HDWU36B29SC-G2	35-3/4"	28"	36" x 30"
HDWU48B29SC-G2	47-3/4"	28"	48" X 30"
HDWU60B29SC-G2	59-3/4"	28"	60" X 30"
HDWU72B29SC-G2	71-3/4"	28"	72" X 30"
HDWU36C29SC-G2	35-3/4"	34"	36" X 36"
HDWU48C29SC-G2	47-3/4"	34"	48" X 36"
HDWU60C29SC-G2	59-3/4"	34"	60" X 36"
HDWU72C29SC-G2	71-3/4"	34"	72" X 36"
HDWU36D29SC-G2	35-3/4"	40"	36" X 42"
HDWU48D29SC-G2	47-3/4"	40"	48" x 42"
HDWU60D29SC-G2	59-3/4"	40"	60" x 42"
HDWU72D29SC-G2	71-3/4"	40"	72" x 42"

### Heavy Duty Welded Tables, 35-3/4" High w/ Shelf Upright Posts & Suspended Cabinet Compatibility

Model	Frame Width	Frame Depth	Top Size
HDWU36A35SC-G2	35-3/4"	23"	36" x 25"
HDWU48A35SC-G2	47-3/4"	23"	48" x 25"
HDWU60A35SC-G2	59-3/4"	23"	60" x 25"
HDWU72A35SC-G2	71-3/4"	23"	72" x 25"
HDWU36B35SC-G2	35-3/4"	28"	36" x 30"
HDWU48B35SC-G2	47-3/4"	28"	48" X 30"
HDWU60B35SC-G2	59-3/4"	28"	60" X 30"
HDWU72B35SC-G2	71-3/4"	28"	72" X 30"
HDWU36C35SC-G2	35-3/4"	34"	36" X 36"
HDWU48C35SC-G2	47-3/4"	34"	48" X 36"
HDWU60C35SC-G2	59-3/4"	34"	60" X 36"
HDWU72C35SC-G2	71-3/4"	34"	72" X 36"
HDWU36D35SC-G2	35-3/4"	40"	36" X 42"
HDWU48D35SC-G2	47-3/4"	40"	48" x 42"
HDWU60D35SC-G2	59-3/4"	40"	60" x 42"
HDWU72D35SC-G2	71-3/4"	40"	72" x 42"

# TABLES – HEAVY DUTY WELDED

## Fixed Height w/ Casters

- Heavy Duty welded construction, complete with caster kits
- Tables can be used with a bottom shelf, or mobile cabinet
- Countertops overhang side edges of table frames by 1/8", 1" overhang at front and rear of frame is typical
- Countertop, brackets, shelves, and cabinets must be ordered separately
- Shipped fully assembled, except for shelves, countertop, or accessories

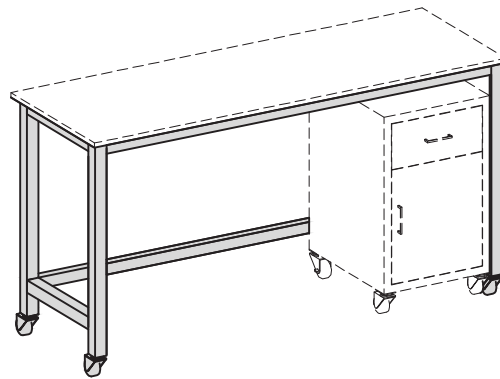

Heavy Duty Welded Tables w/ Casters,  
29-3/4" High

Model	Frame Width	Frame Depth	Top Size
HDW36A29C-G2	35-3/4"	23"	36" x 25"
HDW48A29C-G2	47-3/4"	23"	48" x 25"
HDW60A29C-G2	59-3/4"	23"	60" x 25"
HDW72A29C-G2	71-3/4"	23"	72" x 25"
HDW36B29C-G2	35-3/4"	28"	36" x 30"
HDW48B29C-G2	47-3/4"	28"	48" X 30"
HDW60B29C-G2	59-3/4"	28"	60" X 30"
HDW72B29C-G2	71-3/4"	28"	72" X 30"
HDW36C29C-G2	35-3/4"	34"	36" X 36"
HDW48C29C-G2	47-3/4"	34"	48" X 36"
HDW60C29C-G2	59-3/4"	34"	60" X 36"
HDW72C29C-G2	71-3/4"	34"	72" X 36"
HDW36D29C-G2	35-3/4"	40"	36" X 42"
HDW48D29C-G2	47-3/4"	40"	48" x 42"
HDW60D29C-G2	59-3/4"	40"	60" x 42"
HDW72D29C-G2	71-3/4"	40"	72" x 42"

Heavy Duty Welded Tables w/  
Casters, 35-3/4" High

Model	Frame Width	Frame Depth	Top Size
HDW36A35C-G2	35-3/4"	23"	36" x 25"
HDW48A35C-G2	47-3/4"	23"	48" x 25"
HDW60A35C-G2	59-3/4"	23"	60" x 25"
HDW72A35C-G2	71-3/4"	23"	72" x 25"
HDW36B35C-G2	35-3/4"	28"	36" x 30"
HDW48B35C-G2	47-3/4"	28"	48" X 30"
HDW60B35C-G2	59-3/4"	28"	60" X 30"
HDW72B35C-G2	71-3/4"	28"	72" X 30"
HDW36C35C-G2	35-3/4"	34"	36" X 36"
HDW48C35C-G2	47-3/4"	34"	48" X 36"
HDW60C35C-G2	59-3/4"	34"	60" X 36"
HDW72C35C-G2	71-3/4"	34"	72" X 36"
HDW36D35C-G2	35-3/4"	40"	36" X 42"
HDW48D35C-G2	47-3/4"	40"	48" x 42"
HDW60D35C-G2	59-3/4"	40"	60" x 42"
HDW72D35C-G2	71-3/4"	40"	72" x 42"

## Fixed Height w/ Upright Posts & Casters

[hansonlab.com](http://hansonlab.com) • 805-498-3121

- Heavy Duty welded construction, complete with caster kits
- Tables can be used with a bottom shelf, or mobile cabinet
- Countertops overhang side edges of table frames by 1/8", 1" overhang at front and rear of frame is typical
- Countertop, brackets, shelves, and cabinets must be ordered separately
- Shipped fully assembled, except for shelves, countertop, or accessories
- Total Height 78" to top of upright posts
- Rear upright posts are 2" wide by 2" deep

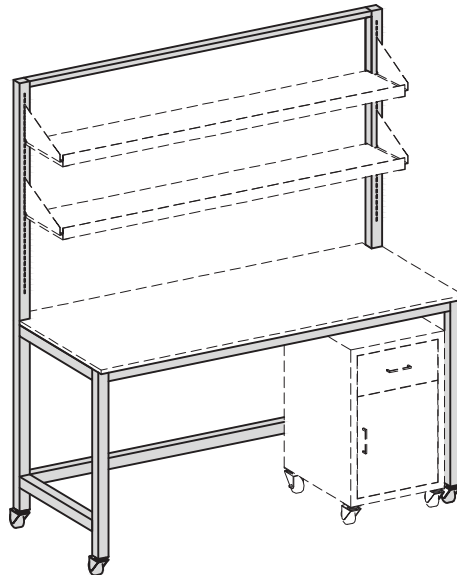

### Heavy Duty Welded Tables w/ Upright Posts & Casters, 29-3/4" High

Model	Frame Width	Frame Depth	Top Size
HDWU36A29C-G2	35-3/4"	23"	36" x 25"
HDWU48A29C-G2	47-3/4"	23"	48" x 25"
HDWU60A29C-G2	59-3/4"	23"	60" x 25"
HDWU72A29C-G2	71-3/4"	23"	72" x 25"
HDWU36B29C-G2	35-3/4"	28"	36" x 30"
HDWU48B29C-G2	47-3/4"	28"	48" X 30"
HDWU60B29C-G2	59-3/4"	28"	60" X 30"
HDWU72B29C-G2	71-3/4"	28"	72" X 30"
HDWU36C29C-G2	35-3/4"	34"	36" X 36"
HDWU48C29C-G2	47-3/4"	34"	48" X 36"
HDWU60C29C-G2	59-3/4"	34"	60" X 36"
HDWU72C29C-G2	71-3/4"	34"	72" X 36"
HDWU36D29C-G2	35-3/4"	40"	36" X 42"
HDWU48D29C-G2	47-3/4"	40"	48" x 42"
HDWU60D29C-G2	59-3/4"	40"	60" x 42"
HDWU72D29C-G2	71-3/4"	40"	72" x 42"

### Heavy Duty Welded Tables w/ Upright Posts & Casters, 35-3/4" High

Model	Frame Width	Frame Depth	Top Size
HDWU36A35C-G2	35-3/4"	23"	36" x 25"
HDWU48A35C-G2	47-3/4"	23"	48" x 25"
HDWU60A35C-G2	59-3/4"	23"	60" x 25"
HDWU72A35C-G2	71-3/4"	23"	72" x 25"
HDWU36B35C-G2	35-3/4"	28"	36" x 30"
HDWU48B35C-G2	47-3/4"	28"	48" X 30"
HDWU60B35C-G2	59-3/4"	28"	60" X 30"
HDWU72B35C-G2	71-3/4"	28"	72" X 30"
HDWU36C35C-G2	35-3/4"	34"	36" X 36"
HDWU48C35C-G2	47-3/4"	34"	48" X 36"
HDWU60C35C-G2	59-3/4"	34"	60" X 36"
HDWU72C35C-G2	71-3/4"	34"	72" X 36"
HDWU36D35C-G2	35-3/4"	40"	36" X 42"
HDWU48D35C-G2	47-3/4"	40"	48" x 42"
HDWU60D35C-G2	59-3/4"	40"	60" x 42"
HDWU72D35C-G2	71-3/4"	40"	72" x 42"

# TABLES – HEAVY DUTY WELDED

## Adjustable Height

- Heavy Duty welded construction, complete with leveling glides
- Tables can be used with a bottom shelf, or mobile cabinet
- Countertops overhang side edges of table frames by 1/8", 1" overhang at front and rear of frame is typical
- Countertop, brackets, shelves, and cabinets must be ordered separately
- Shipped fully assembled, except for shelves, countertop, or accessories
- Total Height 78" to top of upright posts
- Rear upright posts are 2" wide by 2" deep
- Frame height adjustment is from 29-3/4" - 35-3/4" w/ out countertop

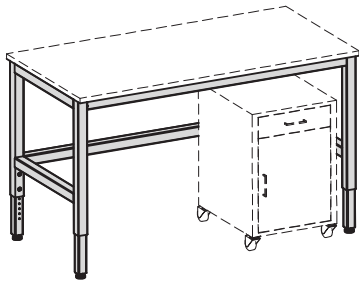

### Heavy Duty Welded Tables Adjustable Height

Model	Frame Width	Frame Depth	Top Size
HDW36AADJ-G2	35-3/4"	23"	36" x 25"
HDW48AADJ-G2	47-3/4"	23"	48" x 25"
HDW60AADJ-G2	59-3/4"	23"	60" x 25"
HDW72AADJ-G2	71-3/4"	23"	72" x 25"
HDW36BADJ-G2	35-3/4"	28"	36" x 30"
HDW48BADJ-G2	47-3/4"	28"	48" X 30"
HDW60BADJ-G2	59-3/4"	28"	60" X 30"
HDW72BADJ-G2	71-3/4"	28"	72" X 30"
HDW36CADJ-G2	35-3/4"	34"	36" X 36"
HDW48CADJ-G2	47-3/4"	34"	48" X 36"
HDW60CADJ-G2	59-3/4"	34"	60" X 36"
HDW72CADJ-G2	71-3/4"	34"	72" X 36"
HDW36DADJ-G2	35-3/4"	40"	36" X 42"
HDW48DADJ-G2	47-3/4"	40"	48" x 42"
HDW60DADJ-G2	59-3/4"	40"	60" x 42"
HDW72DADJ-G2	71-3/4"	40"	72" x 42"

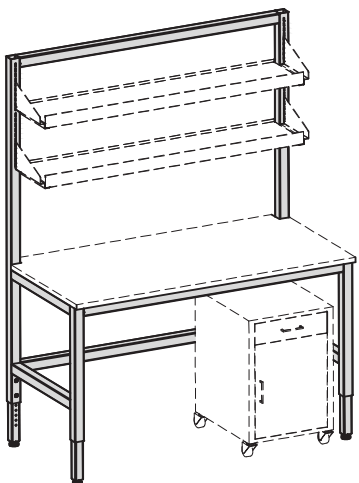

### Heavy Duty Welded Tables, Adjustable Height w/ Shelf Upright Posts

Model	Frame Width	Frame Depth	Top Size
HDWU36AADJ-G2	35-3/4"	23"	36" x 25"
HDWU48AADJ-G2	47-3/4"	23"	48" x 25"
HDWU60AADJ-G2	59-3/4"	23"	60" x 25"
HDWU72AADJ-G2	71-3/4"	23"	72" x 25"
HDWU36BADJ-G2	35-3/4"	28"	36" x 30"
HDWU48BADJ-G2	47-3/4"	28"	48" X 30"
HDWU60BADJ-G2	59-3/4"	28"	60" X 30"
HDWU72BADJ-G2	71-3/4"	28"	72" X 30"
HDWU36CADJ-G2	35-3/4"	34"	36" X 36"
HDWU48CADJ-G2	47-3/4"	34"	48" X 36"
HDWU60CADJ-G2	59-3/4"	34"	60" X 36"
HDWU72CADJ-G2	71-3/4"	34"	72" X 36"
HDWU36DADJ-G2	35-3/4"	40"	36" X 42"
HDWU48DADJ-G2	47-3/4"	40"	48" x 42"
HDWU60DADJ-G2	59-3/4"	40"	60" x 42"
HDWU72DADJ-G2	71-3/4"	40"	72" x 42"

## Adjustable Height w/ Casters

[hansonlab.com](http://hansonlab.com) • 805-498-3121

- Heavy Duty welded construction, complete with casters
- Tables can be used with a bottom shelf, or mobile cabinet
- Countertops overhang side edges of table frames by 1/8", 1" overhang at front and rear of frame is typical
- Countertop, brackets, shelves, and cabinets must be ordered separately
- Shipped fully assembled, except for shelves, countertop, or accessories
- Total Height 78" to top of upright posts
- Rear upright posts are 2" wide by 2" deep
- Frame height adjustment is from 29-3/4" - 35-3/4" w/ out countertop

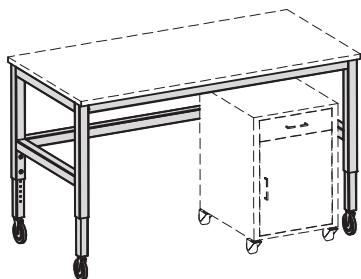

### Heavy Duty Welded Tables, Adjustable Height w/ Casters

Model	Frame Width	Frame Depth	Top Size
HDW36AADJC-G2	35-3/4"	23"	36" x 25"
HDW48AADJC-G2	47-3/4"	23"	48" x 25"
HDW60AADJC-G2	59-3/4"	23"	60" x 25"
HDW72AADJC-G2	71-3/4"	23"	72" x 25"
HDW36BADJC-G2	35-3/4"	28"	36" x 30"
HDW48BADJC-G2	47-3/4"	28"	48" x 30"
HDW60BADJC-G2	59-3/4"	28"	60" x 30"
HDW72BADJC-G2	71-3/4"	28"	72" x 30"
HDW36CADJC-G2	35-3/4"	34"	36" x 36"
HDW48CADJC-G2	47-3/4"	34"	48" x 36"
HDW60CADJC-G2	59-3/4"	34"	60" x 36"
HDW72CADJC-G2	71-3/4"	34"	72" x 36"
HDW36DADJC-G2	35-3/4"	40"	36" x 42"
HDW48DADJC-G2	47-3/4"	40"	48" x 42"
HDW60DADJC-G2	59-3/4"	40"	60" x 42"
HDW72DADJC-G2	71-3/4"	40"	72" x 42"

### Heavy Duty Welded Tables, Adjustable Height w/ Shelf Upright Posts & Casters

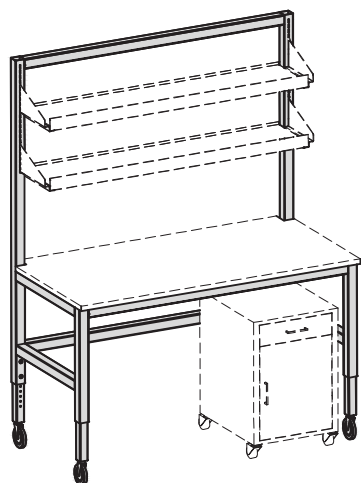

Model	Frame Width	Frame Depth	Top Size
HDWU36AADJC-G2	35-3/4"	23"	36" x 25"
HDWU48AADJC-G2	47-3/4"	23"	48" x 25"
HDWU60AADJC-G2	59-3/4"	23"	60" x 25"
HDWU72AADJC-G2	71-3/4"	23"	72" x 25"
HDWU36BADJC-G2	35-3/4"	28"	36" x 30"
HDWU48BADJC-G2	47-3/4"	28"	48" x 30"
HDWU60BADJC-G2	59-3/4"	28"	60" x 30"
HDWU72BADJC-G2	71-3/4"	28"	72" x 30"
HDWU36CADJC-G2	35-3/4"	34"	36" x 36"
HDWU48CADJC-G2	47-3/4"	34"	48" x 36"
HDWU60CADJC-G2	59-3/4"	34"	60" x 36"
HDWU72CADJC-G2	71-3/4"	34"	72" x 36"
HDWU36DADJC-G2	35-3/4"	40"	36" x 42"
HDWU48DADJC-G2	47-3/4"	40"	48" x 42"
HDWU60DADJC-G2	59-3/4"	40"	60" x 42"
HDWU72DADJC-G2	71-3/4"	40"	72" x 42"

# TABLES – HEAVY DUTY WELDED

## Adjustable Height w/ Suspended Cabinet Mount & Casters

- Heavy Duty welded construction, complete with casters
- Countertops overhang side edges of table frames by 1/8", 1" overhang at front and rear of frame is typical
- Countertop, brackets, shelves, and cabinets must be ordered separately
- Shipped fully assembled, except for shelves, countertop, or accessories
- Total Height 78" to top of upright posts
- Rear upright posts are 2" wide by 2" deep
- Frame height adjustment is from 29-3/4" - 35-3/4" w/ out countertop

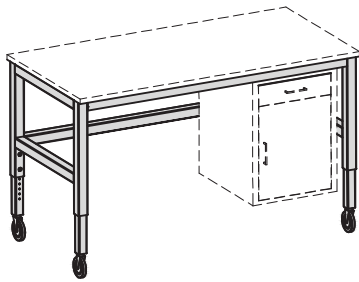

### Heavy Duty Welded Tables, Adjustable Height w/ Suspended Cabinet Compatibility & Casters

Model	Frame Width	Frame Depth	Top Size
HDW36ASCADJC-G2	35-3/4"	23"	36" x 25"
HDW48ASCADJC-G2	47-3/4"	23"	48" x 25"
HDW60ASCADJC-G2	59-3/4"	23"	60" x 25"
HDW72ASCADJC-G2	71-3/4"	23"	72" x 25"
HDW36BSCADJC-G2	35-3/4"	28"	36" x 30"
HDW48BSCADJC-G2	47-3/4"	28"	48" X 30"
HDW60BSCADJC-G2	59-3/4"	28"	60" X 30"
HDW72BSCADJC-G2	71-3/4"	28"	72" X 30"
HDW36CSCADJC-G2	35-3/4"	34"	36" X 36"
HDW48CSCADJC-G2	47-3/4"	34"	48" X 36"
HDW60CSCADJC-G2	59-3/4"	34"	60" X 36"
HDW72CSCADJC-G2	71-3/4"	34"	72" X 36"
HDW36DSCADJC-G2	35-3/4"	40"	36" X 42"
HDW48DSCADJC-G2	47-3/4"	40"	48" x 42"
HDW60DSCADJC-G2	59-3/4"	40"	60" x 42"
HDW72DSCADJC-G2	71-3/4"	40"	72" x 42"

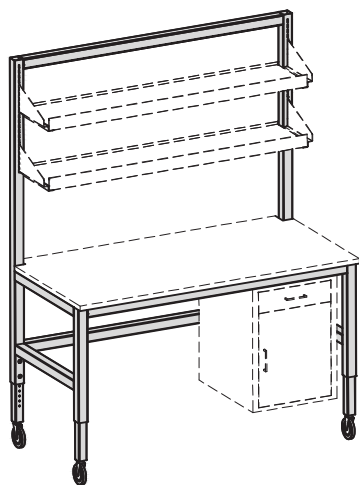

### Heavy Duty Welded Tables, Adjustable Height w/ Shelf Upright Posts, Suspended Cabinet Compatibility & Casters

Model	Frame Width	Frame Depth	Top Size
HDWU36ASCADJC-G2	35-3/4"	23"	36" x 25"
HDWU48ASCADJC-G2	47-3/4"	23"	48" x 25"
HDWU60ASCADJC-G2	59-3/4"	23"	60" x 25"
HDWU72ASCADJC-G2	71-3/4"	23"	72" x 25"
HDWU36BSCADJC-G2	35-3/4"	28"	36" x 30"
HDWU48BSCADJC-G2	47-3/4"	28"	48" X 30"
HDWU60BSCADJC-G2	59-3/4"	28"	60" X 30"
HDWU72BSCADJC-G2	71-3/4"	28"	72" X 30"
HDWU36CSCADJC-G2	35-3/4"	34"	36" X 36"
HDWU48CSCADJC-G2	47-3/4"	34"	48" X 36"
HDWU60CSCADJC-G2	59-3/4"	34"	60" X 36"
HDWU72CSCADJC-G2	71-3/4"	34"	72" X 36"
HDWU36DSCADJC-G2	35-3/4"	40"	36" X 42"
HDWU48DSCADJC-G2	47-3/4"	40"	48" x 42"
HDWU60DSCADJC-G2	59-3/4"	40"	60" x 42"
HDWU72DSCADJC-G2	71-3/4"	40"	72" x 42"



- Tables can be used with upright posts, upper shelves, lower shelf, power strip kit, single drawer or mobile cabinet
- Countertop, brackets, shelves, and cabinets must be ordered separately
- Typical countertop overhang on Utility Table frame is 1/8" at sides, 1" at front, flush at rear (for optional upright kit installation)
- Assembly required

### Adjustable Height Frames

Frame height adjustment is from 29-3/4" - 35-3/4" w/out countertop

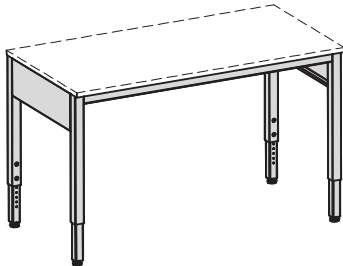

Model	Frame Width	Frame Depth	Top Size
UTA36B	35-3/4"	29"	36" x 30"
UTA48B	47-3/4"	29"	48" x 30"
UTA60B	59-3/4"	29"	60" x 30"
UTA72B	71-3/4"	29"	72" x 30"
UTA36C	35-3/4"	35"	36" x 36"
UTA48C	47-3/4"	35"	48" X 36"
UTA60C	59-3/4"	35"	60" X 36"
UTA72C	71-3/4"	35"	72" X 36"

### Fixed Height Frames

Frame height is 35-3/4" w/out countertop

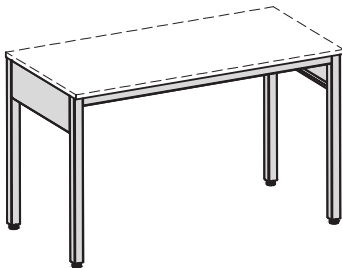

Model	Frame Width	Frame Depth	Top Size
UTFH36B	35-3/4"	29"	36" x 30"
UTFH48B	47-3/4"	29"	48" x 30"
UTFH60B	59-3/4"	29"	60" x 30"
UTFH72B	71-3/4"	29"	72" x 30"
UTFH36C	35-3/4"	35"	36" x 36"
UTFH48C	47-3/4"	35"	48" X 36"
UTFH60C	59-3/4"	35"	60" X 36"
UTFH72C	71-3/4"	35"	72" X 36"

### Fixed Height Frames

Frame height is 29-3/4" w/out countertop

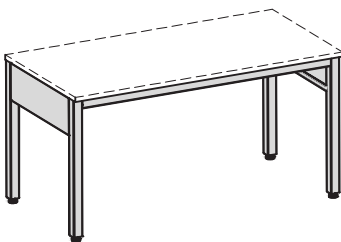

Model	Frame Width	Frame Depth	Top Size
UTFL36B	35-3/4"	29"	36" x 30"
UTFL48B	47-3/4"	29"	48" x 30"
UTFL60B	59-3/4"	29"	60" x 30"
UTFL72B	71-3/4"	29"	72" x 30"
UTFL36C	35-3/4"	35"	36" x 36"
UTFL48C	47-3/4"	35"	48" X 36"
UTFL60C	59-3/4"	35"	60" X 36"
UTFL72C	71-3/4"	35"	72" X 36"

# UTILITY TABLES

## Accessories

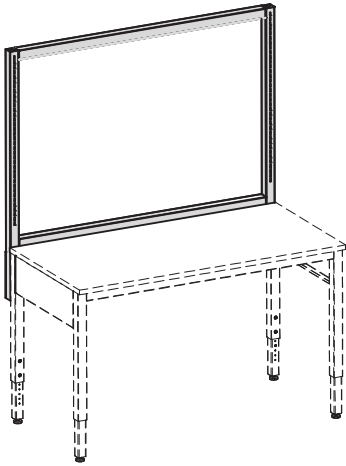

### Upright Post Kits

Includes 2" X 2" vertical posts, horizontal cross members, and hardware. Table, shelves, and shelf brackets not included

Model	Frame Width	Frame Height
K13409-36	35-3/4"	52-1/2"
K13409-48	47-3/4"	52-1/2"
K13409-60	59-3/4"	52-1/2"
K13409-72	71-3/4"	52-1/2"

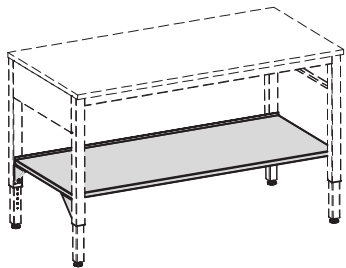

### Lower Shelving Kits

Under counter use includes shelf, & mounting brackets. Table frame, & work surface sold separately.

Model	Length	Depth
K7003-36	35-1/2"	24-3/4"
K7003-48	47-1/2"	24-3/4"
K7003-60	59-3/4"	24-3/4"
K7003-72	71-3/4"	24-3/4"

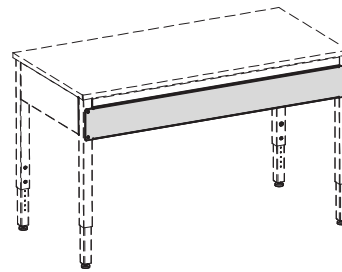

### Rear Apron

Suggested for applications with dynamic equipment

Model	Length	Height
C13406-36	36"	6-1/2"
C13406-48	48"	6-1/2"
C13406-60	60"	6-1/2"
C13406-72	72"	6-1/2"

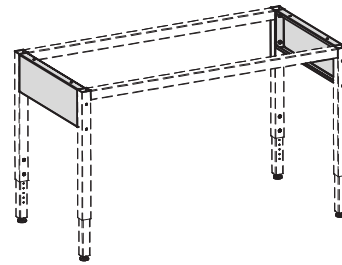

### Frame Depth Extension Apron

Frame depth extension aprons accommodates 24" or 36" deep work surface (sold separately)

Model	Apron Width	Finished Frame Depth
K13408-24-1	18"	22"
K13408-24	19"	23"
K13408-36-1	30"	34"
K13408-36	31"	35"

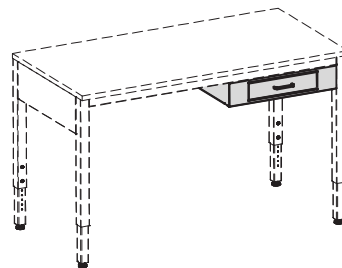

### Single Drawer

Includes single 24" x 28" drawer housing. Table frame and work surface sold separately.

Model	Width	Depth
DH-1-24B	24-1/8"	28"

## Work Surface

HDW and Agility benches w/ out upright posts and all Utility table applications. Chemical resistant black phenolic resin (36" deep sizes can be custom ordered)

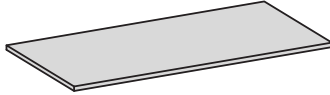

Model	Length	Depth	Thickness
CTOP-PHEN3630-1.0IN	36"	30"	1"
CTOP-PHEN4830-1.0IN	48"	30"	1"
CTOP-PHEN6030-1.0IN	60"	30"	1"
CTOP-PHEN7230-1.0IN	72"	30"	1"

## Caster Kit

1/2"-13 Stem swivel casters with brake, use with HDW & Utility Table for light duty applications

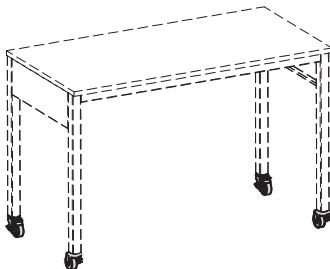

Model	Size
H260	Caster, 3"Ø Lt Med Gray 4.25" OAH
H261	Caster, 3.5"Ø Lt Med Gray 4.75" OAH
H262	Caster, 4"Ø Lt Med Gray, 5.25" OAH

## Lower Shelving for Agility Essential & HDW

Painted steel shelf - attaches to lower horizontal support. Table cross brace is suggested for heavy duty applications

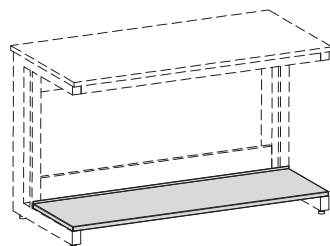
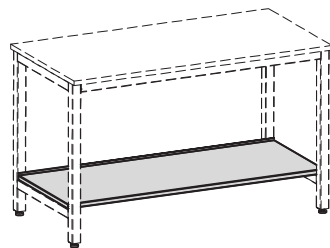

Model	Shelf Width	Shelf Depth
TS36A-G2	35-1/2"	18-3/4"
TS36B-G2	35-1/2"	23-1/2"
TS48A-G2	47-1/2"	18-3/4"
TS48B-G2	47-1/2"	23-1/2"
TS60A-G2	59-1/2"	18-3/4"
TS60B-G2	59-1/2"	23-1/2"
TS72A-G2	71-1/2"	18-3/4"
TS72B-G2	71-1/2"	23-1/2"

## Table Cross Brace

Cross brace for added support of the bottom shelf

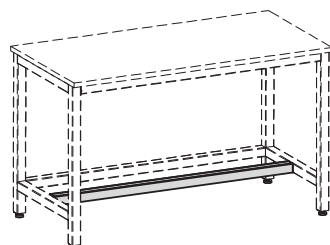

Model	Brace Width	Work Surface Width
CB36-G2	31-3/4"	36"
CB48-G2	43-3/4"	48"
CB60-G2	55-3/4"	60"
CB72-G2	67-3/4"	72"

# TABLE ACCESSORIES

## Power Strips, Bin Box Mounts, Upper Shelves

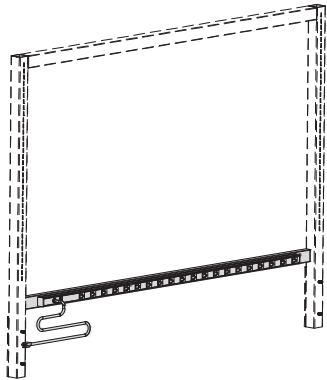

### Power Strip Kits (15A)

Upright Post Kits Sold Separately

Model	Mount Width	Strip Length	Cord Length	Outlet Qty.
K13411-36	34.65"	24"	6'	8
K13411-48	46.65"	36"	15'	12
K13411-60	58.65"	48"	15'	8
K13411-72	70.65"	60"	15'	20

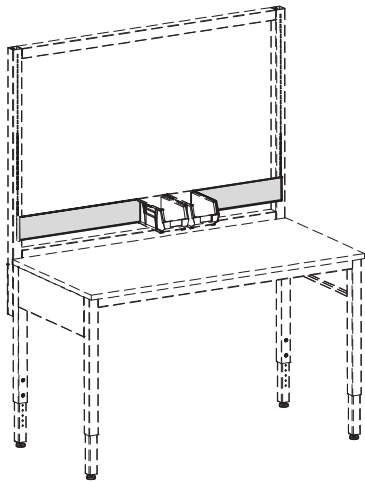

### Bin Box Mounts

Bin box not included

Model	Length
A13412-36	36"
A13412-48	48"
A13412-60	60"
A13412-72	72"

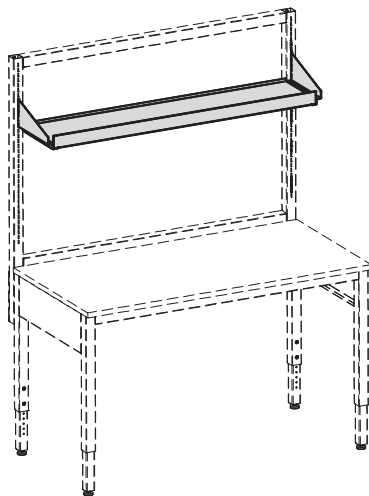

### Upper Shelf Kits\*

Includes 12" deep painted metal shelf, and brackets.

Requires upright post kit, and table sold separately.

Model	Width	Depth
K13070-12	31-1/2"	12"
K13032-12	43-1/2"	12"
K13033-12	55-1/2"	12"
K13034-12	67-1/2"	12"

\*see page 103 for full range of HLS shelving sizes & styles

## Ceiling Service Panels

- Designed to fit inside a standard ceiling tile grid when service connection from the ceiling is desired
- Typically paired with modular benches equipped with Service Hub or accessory panel
- Painted steel panel construction
- Stainless Steel available (use -SS as part number suffix)
- Service panels may be customized to meet your project requirements
- Order service fixtures separately

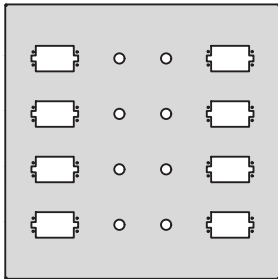
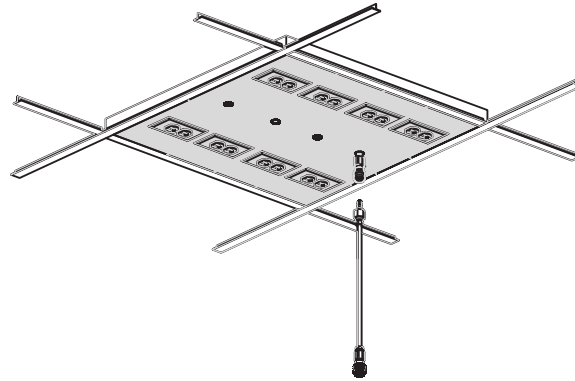

**C1600**  
23-1/2" x 23-1/2" 8 Electrical cutouts & 8 Plumbing cutouts

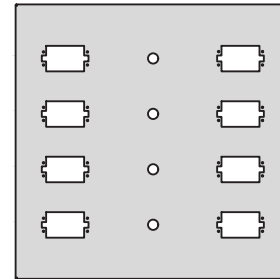

**C1601**  
23-1/2" x 23-1/2" 8 Electrical cutouts & 4 Plumbing cutouts

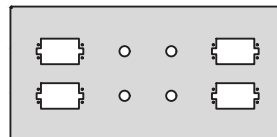

**C1603**  
23-1/2" x 11-1/2" 4 Electrical cutouts & 4 Plumbing cutouts

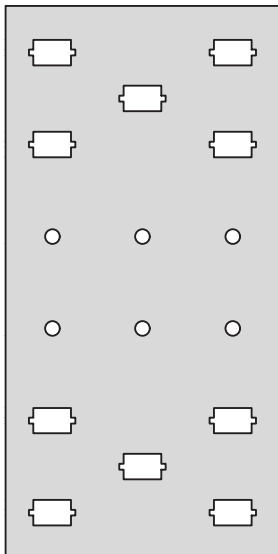

**C1605**  
23-1/2" x 47-1/2" 10 Electrical cutouts & 6 Plumbing cutouts

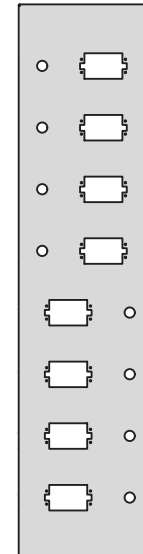

**C1606**  
11-1/2" x 47-1/2" 8 Electrical cutouts & 8 Plumbing cutouts

# CEILING SERVICE PANEL COUPLERS

## Premium Coupler

- Color coded and keyed to keep service hoses from being connected to the wrong service

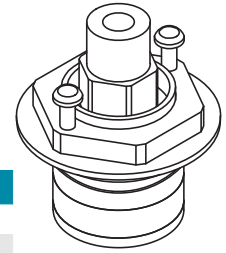

Model	Description
QCFL-B-3M-K2	QUICK CONNECT BODY, POLISHED CHROME FINISH, 3/8" NPT MALE INLET, ORANGE
QCFL-B-3M-K4	QUICK CONNECT BODY, POLISHED CHROME FINISH, 3/8" NPT MALE INLET, YELLOW
QCFL-B-3M-K6	QUICK CONNECT BODY, POLISHED CHROME FINISH, 3/8" NPT MALE INLET, WHITE
QCFL-B-3M-K7	QUICK CONNECT BODY, POLISHED CHROME FINISH, 3/8" NPT MALE INLET, PURPLE
QCFL-B-3M-K8	QUICK CONNECT BODY, POLISHED CHROME FINISH, 3/8" NPT MALE INLET, BROWN

Note: Corresponding male connections will be pre-plumbed on the Agility or M-Series bench

## Industrial Style Coupler & Components

### Brass mounting shank assembly

Model	Description
BI136-02-08R	MOUNTING SHANK, BRASS, 3/8" IPS X 2-1/2", W/ LOCK NUT & WASHER

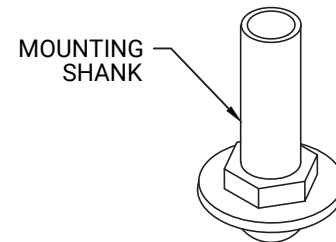

### ISO 6150/B quick-connect coupler fitting, chrome plated brass

- Used with 14P48-H14-BS male ISO connector (see note at bottom of page)

Model	Description
14SFWS-N3F-BS	COUPLING SOCKET, CHR M PLT, 1/4 INTERCHANGE, 3/8 NPT FEM, W/ GROOVE

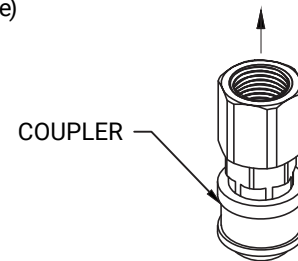

### Coupling indicator rings

- Mate with 14FWS-N3F-BS coupling
- Color keyed silicone rings to match with hoses that supply workstation services

Model	Description
H334-BRN	COUPLING INDICATOR RING, BROWN SILICONE
H334-ORG	COUPLING INDICATOR RING, ORANGE SILICONE
H334-PNK	COUPLING INDICATOR RING, PINK SILICONE
H334-VIO	COUPLING INDICATOR RING, VIOLET SILICONE
H334-YLW	COUPLING INDICATOR RING, YELLOW SILICONE

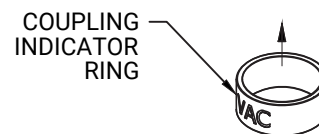

Note: 14P48-H14-BS male ISO connector will be pre-plumbed on the Agility or M-Series bench

**Shelving options for every need, budget, and design solutions.**

HLS shelving and accessories are interchangeable within most HLS table families.

The correct shelving choice makes a big difference in the functionality of your lab.

Hanson offers a variety of shelving options for all of your storage needs. We offer everything from economical fixed island and wall shelving to adjustable shelving that can be reconfigured to fit changing applications.

### Shelving Index

Page

<b>WALL STANDARDS</b> .....	104
<b>SHELF BRACKETS</b> .....	104
<b>ISLAND SHELVING</b> .....	105
• Benchtop Mounted .....	105
• Floor-Mounted .....	106
<b>INDIVIDUAL SHELVES</b> .....	107
• Painted Steel Shelving (std & HD).....	107
• Painted Steel Shelving with SS Retention Rod .....	108
• Painted Steel Shelving with SS Retention Hoop .....	109
• Painted Steel Shelving with Acrylic Lip.....	110
• Painted Steel Shelving with 3 Sided Retention Lip.....	111
<b>SHELVING ACCESSORIES</b> .....	112
• Under-Shelf LED Task Lights .....	112

*NOTE: Alternate shelving materials and styles may also be available. Contact your HLS Sales representative for more details*



# SHELVING

## Wall Standards, Shelf Brackets

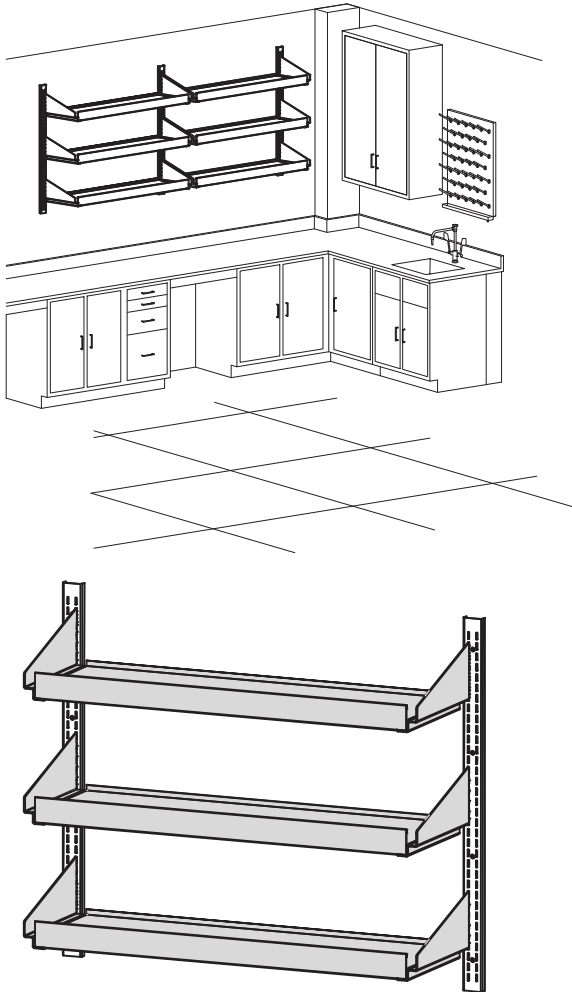

### Heavy Duty Wall Shelving System

- Heavy duty laboratory wall shelving system
- Shelves are adjustable in 1" increments
- In-wall backing required for all wall shelving
- Wall standards and brackets are painted to match casework
- Alternate materials available
- Components sold individually

### Wall Standards

- Wall standards are painted steel, 12 ga., 2" w x 5/8" d, double slotted for use with bookend brackets

Model	Height
HDS36-G2	36"
HDS48-G2	48"
HDS60-G2	60"
HDS72-G2	72"

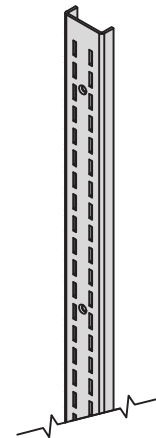

Each model number includes one wall standard.

### Bookend Brackets

- Offset style bookend brackets are 6.9" high, 11 ga. painted steel

Model	Shelf Bracket	Used With
C13025-SET	10"	10" or 12" D shelves
C13026-SET	12"	12" or 14" D shelves
C13027-SET	14"	14" or 16" D shelves
C13127-SET	16"	16" or 18" D shelves

Each model number includes a set of Left and Right hand brackets

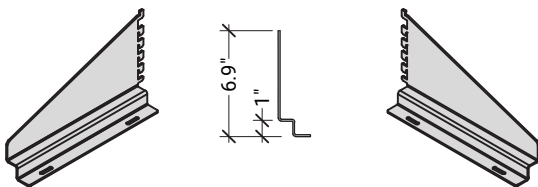

### Inverted Top Brackets

- Positions the top shelf surfaces 5/8" below top of post (see page 111 for "flush mount" upper shelves and brackets)
- Reversed offset style bookend brackets are 4.9" high, 11 ga. painted steel

Model	Shelf Bracket	Used With
C13028-SET	10"	10" D shelves
C13029-SET	12"	12" D shelves
C13030-SET	14"	14" D shelves
C13031-SET	16"	16" D shelves

Each model number includes a set of Left and Right hand brackets

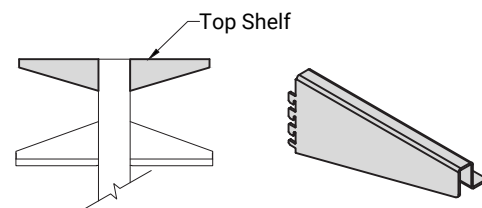



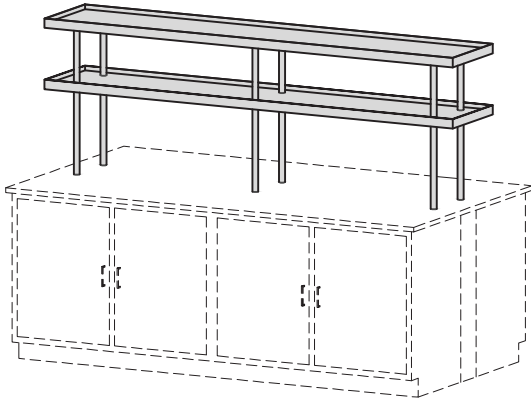

### Bench Top Fixed Height Shelving System

- Used for island, peninsula, or at wall locations where shelves cannot be mounted to walls
- Shelves are fixed
- Upright poles can support 1, 2, or 3 tiers of shelves

### Plastic Laminate Shelving

- 1" thick laminate shelves with 3mm PVC black retainer lips on all sides

### Upright Kits

- Uprights are Ø1-1/4" brushed stainless steel for attachment to shelves and counters
- Shelf spans longer than 48" should have a center set of poles
- Hardware included

Model	Height
UP212	12" tall set of 2
UP218	18" tall set of 2
UP224	24" tall set of 2
UP218-12	18" & 12" tall sets of 2
UP224-12	24" & 12" tall sets of 2
UP224-18	24" & 18" tall sets of 2

### Bench Top Adjustable Shelving System

- Can be used on new or existing island and peninsula benches
- Components shown are sold individually, select matching widths for your application
- 48" high x 2" wide x 3" deep powdercoated steel uprights mount onto the countertop through integrated mounting plate
- Upright posts are located at center and end locations
- End posts must be positioned a minimum of 3-1/4" from end of counter top at each side
- A center cord gap is provided between shelves for vertical integration of shelf equipment
- Shelves are adjustable and removable
- Shelving system is compatible with standard Hanson shelves (See shelving pages starting on page 107 for sizes and styles)

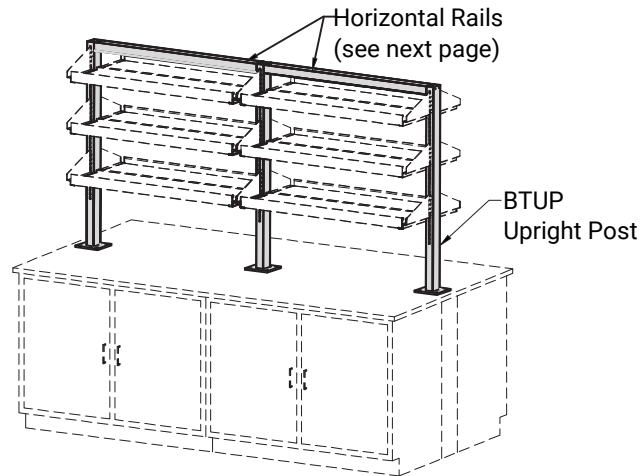

### Bench Top Upright Post (BTUP)

- Upright Post (each; includes bench top mounting hardware)

Model	Size	Height
BTUP48-G2	2" W X 3" D	29-3/4"

# ISLAND SHELVING

## Floor Mounted System

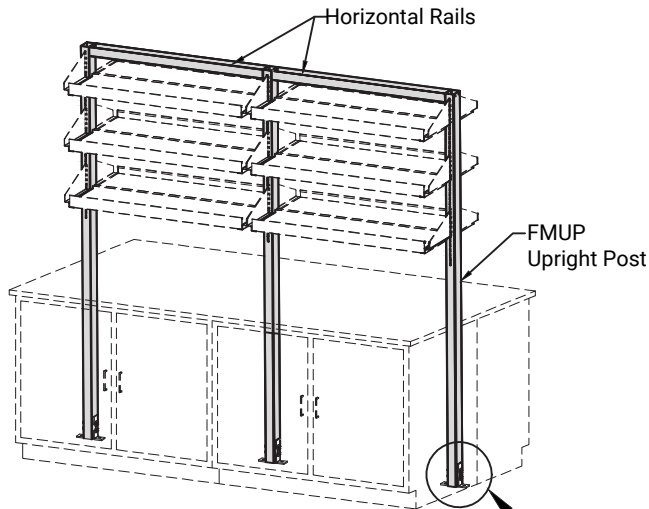

### Floor Mounted Adjustable Shelving System

- Can be used on new island and peninsula benches
- Shelves are adjustable and removable
- 84" high x 2" wide x 3" deep painted steel uprights install to the floor through the counter top (floor mounting brackets are included)
- A center cord gap is provided between shelves for vertical integration of shelf equipment
- See the shelving page for shelving sizes and styles
- Components sold individually

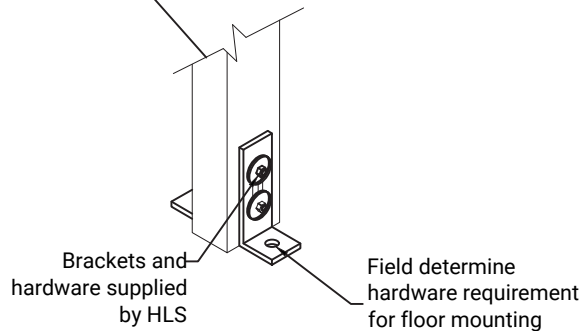

### Floor Mounted Upright Posts (FMUP)

- Floor mounted upright posts are used at end and center locations
- End posts must be positioned a minimum of 3-1/4" from end of countertop at each side
- Includes floor mounting hardware (see image above)

Model	Size	Height
FMUP84-G2	2" W X 3" D	84"

### Horizontal Top Rails

- Top rails attach between upright posts installed at the center lines listed below

Model	Width	Centerline of Upright Post
C13174-31	31-3/4"	33-3/4"
C13174-43	43-3/4"	45-3/4"
C13174-55	55-3/4"	57-3/4"
C13174-67	67-3/4"	69-3/4"

### Standard Shelving

Most commonly supplied HLS shelf (default shelf option)

- 1" thick 18 ga. painted steel with integral front and rear retention lips
- Available in HLS standard colors, powder coated to match casework
- Part numbers starting with "A" are the same size however they are designed to be used with the optional HLS task lights (see page 112)

Model	Shelf Width	Shelf Depth
C13070-10	31-1/2"	10"
A13070-10L	31-1/2"	10"
C13070-12	31-1/2"	12"
A13070-12L	31-1/2"	12"
C13070-14	31-1/2"	14"
A13070-14L	31-1/2"	14"
C13070-16	31-1/2"	16"
A13070-16L	31-1/2"	16"
C13070-18	31-1/2"	18"
A13070-18L	31-1/2"	18"
C13032-10	43-1/2"	10"
A13032-10L	43-1/2"	10"
C13032-12	43-1/2"	12"
A13032-12L	43-1/2"	12"
C13032-14	43-1/2"	14"
A13032-14L	43-1/2"	14"
C13032-16	43-1/2"	16"
A13032-16L	43-1/2"	16"
C13032-18	43-1/2"	18"
A13032-18L	43-1/2"	18"
C13033-10	55-1/2"	10"
A13033-10L	55-1/2"	10"
C13033-12	55-1/2"	12"
A13033-12L	55-1/2"	12"
C13033-14	55-1/2"	14"
A13033-14L	55-1/2"	14"
C13033-16	55-1/2"	16"
A13033-16L	55-1/2"	16"
C13033-18	55-1/2"	18"
A13033-18L	55-1/2"	18"
C13034-10	67-1/2"	10"
A13034-10L	67-1/2"	10"
C13034-12	67-1/2"	12"
A13034-12L	67-1/2"	12"
C13034-14	67-1/2"	14"
A13034-14L	67-1/2"	14"
C13034-16	67-1/2"	16"
A13034-16L	67-1/2"	16"
C13034-18	67-1/2"	18"
A13034-18L	67-1/2"	18"

### Heavy-Duty Shelving

- 1" thick 18 ga. painted steel with integral front and rear retention lips
- Available in HLS standard colors, powder coated to match casework
- Integrated 18 ga. hat channel for greater load capacity

Model	Shelf Width	Shelf Depth
C13119-10	31-1/2"	10"
C13119-12	31-1/2"	12"
C13119-14	31-1/2"	14"
C13119-16	31-1/2"	16"
C13119-18	31-1/2"	18"
C13120-10	43-1/2"	10"
C13120-12	43-1/2"	12"
C13120-14	43-1/2"	14"
C13120-16	43-1/2"	16"
C13120-18	43-1/2"	18"
C13121-10	55-1/2"	10"
C13121-12	55-1/2"	12"
C13121-14	55-1/2"	14"
C13121-16	55-1/2"	16"
C13121-18	55-1/2"	18"
C13122-10	67-1/2"	10"
C13122-12	67-1/2"	12"
C13122-14	67-1/2"	14"
C13122-16	67-1/2"	16"
C13122-18	67-1/2"	18"

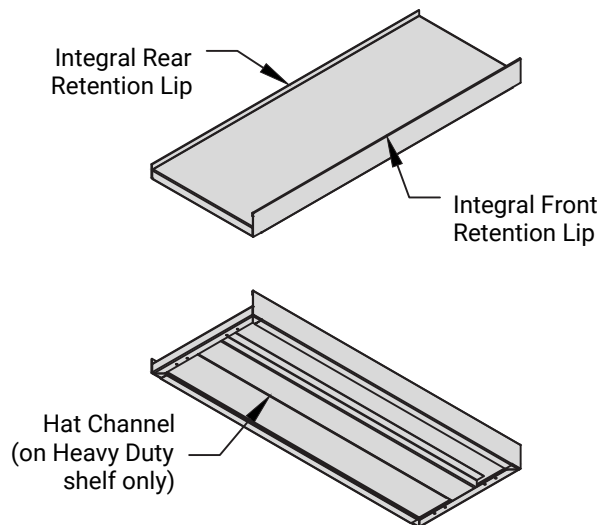

# SHELVING

## Painted Steel Shelving w/ Stainless Retention Rods and Stanchions

- 1" thick 18 ga. painted steel with integral rear retention lip
- Stainless Steel front retention rods and stanchions
- Available in HLS standard colors to match casework
- Part numbers ending with "L" are the same size however they are designed to be used with the optional HLS task lights (see page 112)

Model	Shelf Width	Shelf Depth
A13071-10	31-1/2"	10"
A13071-10L	31-1/2"	10"
A13071-12	31-1/2"	12"
A13071-12L	31-1/2"	12"
A13071-14	31-1/2"	14"
A13071-14L	31-1/2"	14"
A13071-16	31-1/2"	16"
A13071-16L	31-1/2"	16"
A13071-18	31-1/2"	18"
A13071-18L	31-1/2"	18"
A13035-10	43-1/2"	10"
A13035-10L	43-1/2"	10"
A13035-12	43-1/2"	12"
A13035-12L	43-1/2"	12"
A13035-14	43-1/2"	14"
A13035-14L	43-1/2"	14"
A13035-16	43-1/2"	16"
A13035-16L	43-1/2"	16"
A13035-18	43-1/2"	18"
A13035-18L	43-1/2"	18"
A13036-10	55-1/2"	10"
A13036-10L	55-1/2"	10"
A13036-12	55-1/2"	12"
A13036-12L	55-1/2"	12"
A13036-14	55-1/2"	14"
A13036-14L	55-1/2"	14"
A13036-16	55-1/2"	16"
A13036-16L	55-1/2"	16"
A13036-18	55-1/2"	18"
A13036-18L	55-1/2"	18"
A13037-10	67-1/2"	10"
A13037-10L	67-1/2"	10"
A13037-12	67-1/2"	12"
A13037-12L	67-1/2"	12"
A13037-14	67-1/2"	14"
A13037-14L	67-1/2"	14"
A13037-16	67-1/2"	16"
A13037-16L	67-1/2"	16"
A13037-18	67-1/2"	18"
A13037-18L	67-1/2"	18"

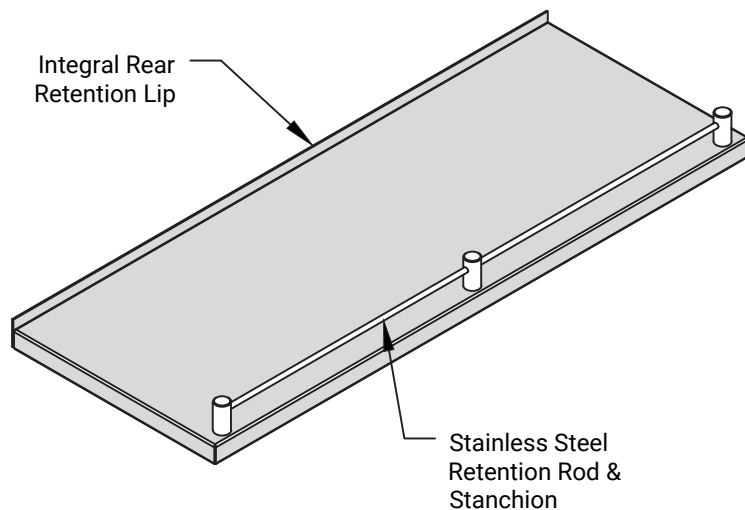

## Painted Steel Shelving w/ Stainless Steel Retention Hoop

[hansonlab.com](http://hansonlab.com) • 805-498-3121

- 1" thick 18 ga. painted steel with integral rear retention lip
- Stainless Steel front retention hoops
- Available in HLS standard colors to match casework
- Part numbers ending with "L" are the same size however they are designed to be used with the optional HLS task lights (see page 112)

Model	Shelf Width	Shelf Depth
A13154-10	31-1/2"	10"
A13154-10L	31-1/2"	10"
A13154-12	31-1/2"	12"
A13154-12L	31-1/2"	12"
A13154-14	31-1/2"	14"
A13154-14L	31-1/2"	14"
A13154-16	31-1/2"	16"
A13154-16L	31-1/2"	16"
A13154-18	31-1/2"	18"
A13154-18L	31-1/2"	18"
A13155-10	43-1/2"	10"
A13155-10L	43-1/2"	10"
A13155-12	43-1/2"	12"
A13155-12L	43-1/2"	12"
A13155-14	43-1/2"	14"
A13155-14L	43-1/2"	14"
A13155-16	43-1/2"	16"
A13155-16L	43-1/2"	16"
A13155-18	43-1/2"	18"
A13155-18L	43-1/2"	18"
A13156-10	55-1/2"	10"
A13156-10L	55-1/2"	10"
A13156-12	55-1/2"	12"
A13156-12L	55-1/2"	12"
A13156-14	55-1/2"	14"
A13156-14L	55-1/2"	14"
A13156-16	55-1/2"	16"
A13156-16L	55-1/2"	16"
A13156-18	55-1/2"	18"
A13156-18L	55-1/2"	18"
A13157-10	67-1/2"	10"
A13157-10L	67-1/2"	10"
A13157-12	67-1/2"	12"
A13157-12L	67-1/2"	12"
A13157-14	67-1/2"	14"
A13157-14L	67-1/2"	14"
A13157-16	67-1/2"	16"
A13157-16L	67-1/2"	16"
A13157-18	67-1/2"	18"
A13157-18L	67-1/2"	18"

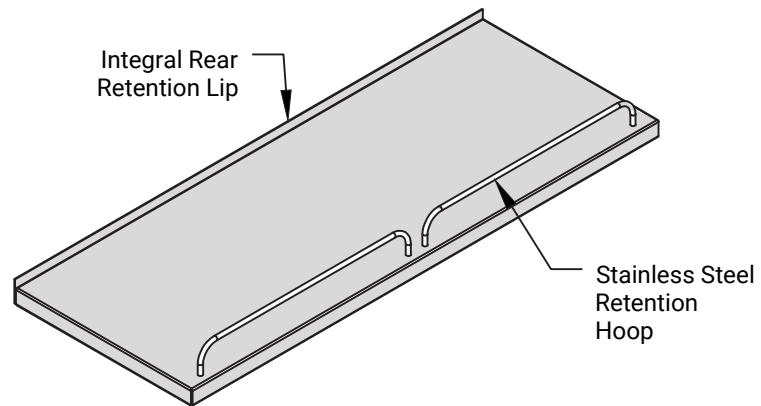

# SHELVING

## Painted Steel Shelving w/ Front Acrylic Lip

- 1" thick 18 ga. painted steel with integral rear retention lips and clear 1/8" front acrylic retention lip
- Available in HLS standard colors to match casework
- Part numbers ending with "L" are the same size however they are designed to be used with the optional HLS task lights (see page 112)

Note: Optional front lip materials are available. See your HLS Sales Representative.

Model	Shelf Width	Shelf Depth
A13129-10	31-1/2"	10"
A13129-10L	31-1/2"	10"
A13129-12	31-1/2"	12"
A13129-12L	31-1/2"	12"
A13129-14	31-1/2"	14"
A13129-14L	31-1/2"	14"
A13129-16	31-1/2"	16"
A13129-16L	31-1/2"	16"
A13129-18	31-1/2"	18"
A13129-18L	31-1/2"	18"
A13130-10	43-1/2"	10"
A13130-10L	43-1/2"	10"
A13130-12	43-1/2"	12"
A13130-12L	43-1/2"	12"
A13130-14	43-1/2"	14"
A13130-14L	43-1/2"	14"
A13130-16	43-1/2"	16"
A13130-16L	43-1/2"	16"
A13130-18	43-1/2"	18"
A13130-18L	43-1/2"	18"
A13131-10	55-1/2"	10"
A13131-10L	55-1/2"	10"
A13131-12	55-1/2"	12"
A13131-12L	55-1/2"	12"
A13131-14	55-1/2"	14"
A13131-14L	55-1/2"	14"
A13131-16	55-1/2"	16"
A13131-16L	55-1/2"	16"
A13131-18	55-1/2"	18"
A13131-18L	55-1/2"	18"
A13132-10	67-1/2"	10"
A13132-10L	67-1/2"	10"
A13132-12	67-1/2"	12"
A13132-12L	67-1/2"	12"
A13132-14	67-1/2"	14"
A13132-14L	67-1/2"	14"
A13132-16	67-1/2"	16"
A13132-16L	67-1/2"	16"
A13132-18	67-1/2"	18"
A13132-18L	67-1/2"	18"

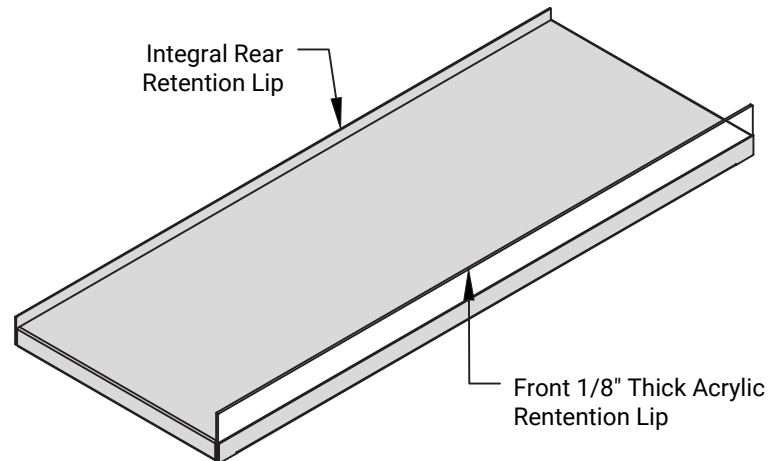

### Painted Steel Shelving With 3 Sided Retention Lips

- 1" thick 18 ga. painted steel with integral front and side retention lips
- Available in HLS standard colors to match casework
- These shelves are intended to be used at the top of the post to create a "flush" top-deck surface when specifically paired with the inverted shelf brackets shown below

Model	Shelf Width	Shelf Depth
C13123-10	31-1/2"	10"
C13123-12	31-1/2"	12"
C13123-14	31-1/2"	14"
C13123-16	31-1/2"	16"
C13124-10	43-1/2"	10"
C13124-12	43-1/2"	12"
C13124-14	43-1/2"	14"
C13124-16	43-1/2"	16"
C13125-10	55-1/2"	10"
C13125-12	55-1/2"	12"
C13125-14	55-1/2"	14"
C13125-16	55-1/2"	16"
C13126-10	67-1/2"	10"
C13126-12	67-1/2"	12"
C13126-14	67-1/2"	14"
C13126-16	67-1/2"	16"

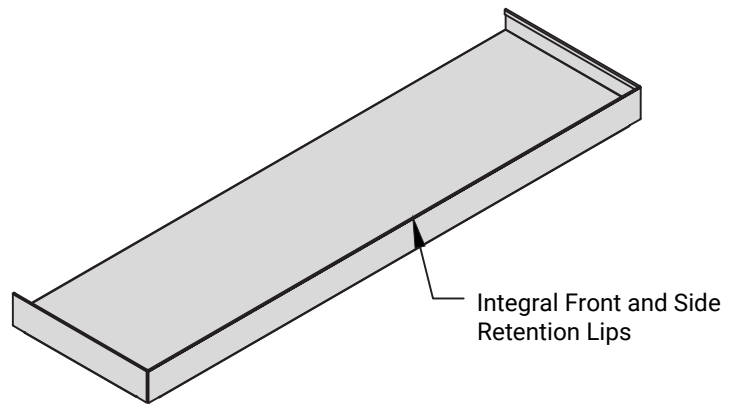

### Inverted Top Brackets (flush mount)

- Positions the top shelf surface flush with top of the post
- Reversed offset style bookend brackets are 4.9" high, 11 ga. painted steel

Model	Shelf Bracket	Used With
C13113-SET	10"	10" D shelves
C13114-SET	12"	12" D shelves
C13115-SET	14"	14" D shelves
C13116-SET	16"	16" D shelves

Each model number includes a set of Left and Right hand brackets

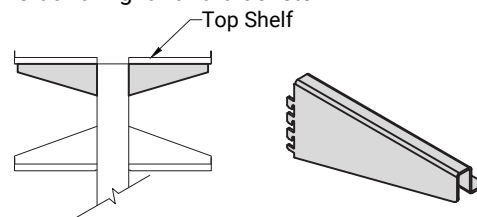

# SHELVING ACCESSORIES

## Under-Shelf LED Task Lights & Power Supply

### Under Mount Shelf LED Task Lights

- Mates to HLS shelving equipped with LED channel receiver (HLS shelf part numbers containing 'L' suffix)
- 5000K color temperature; CRI > 90
- Two switch types available: motion sensor or on/off pushbutton w/ dimming feature
- Motion Sensor Detector has a delay time of 40 seconds which is the duration of lighting after motion is no longer detected in the space
- Easily linkable in one continuous line using integrated 5.5mm extensions; allows multiple strips to be daisy-chained
- 24VDC input (60W HLS power supply available, PN: E164)

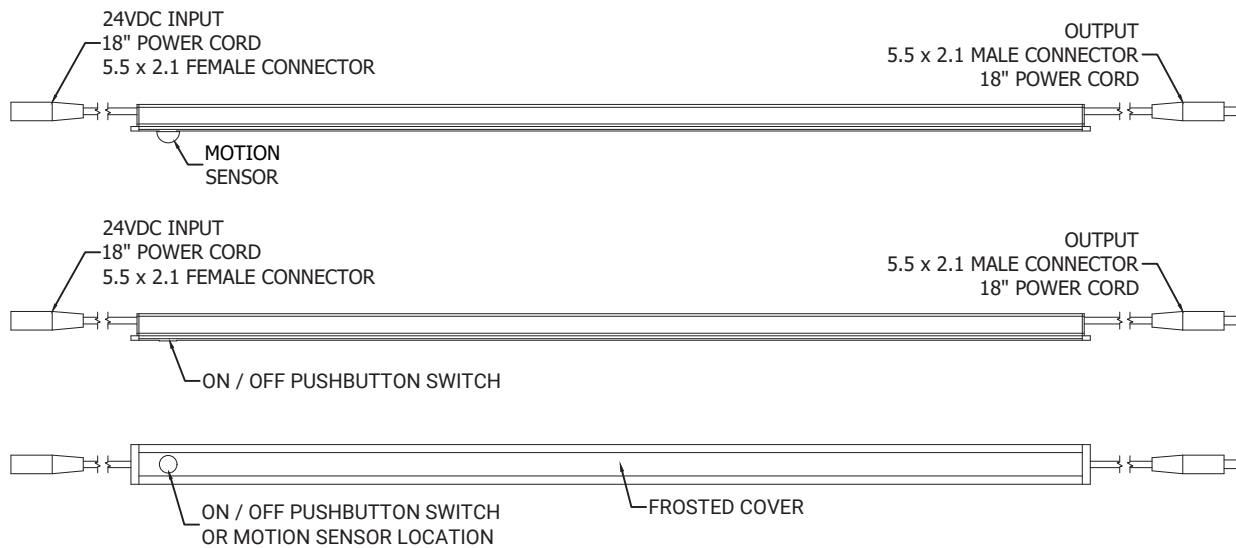
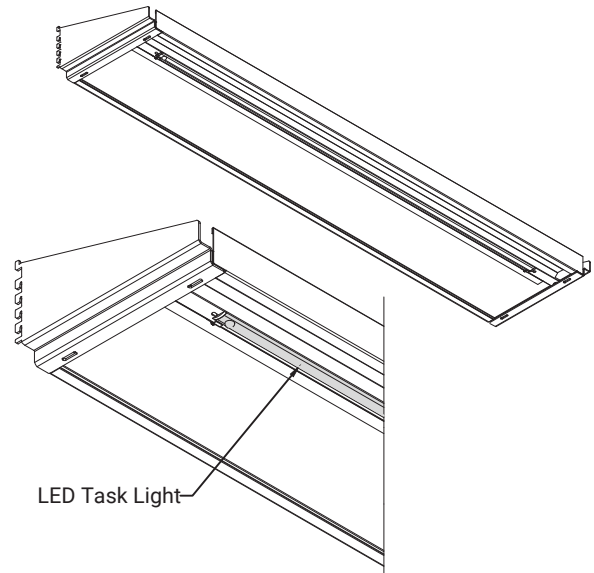

Model	Length and Switch type	Use with "L" Shelf
E155	5' On/Off Pushbutton Switch	67-1/2" wide
E156	5' Motion Sensor	67-1/2" wide
E157	4' On/Off Pushbutton Switch	55-1/2" wide
E158	4' Motion Sensor	55-1/2" wide
E159	3' On/Off Pushbutton Switch	43-1/2" wide
E160	3' Motion Sensor	43-1/2" wide
E161	2' On/Off Pushbutton Switch	31-1/2" wide
E162	2' Motion Sensor	31-1/2" wide

### Task Lights Power Supply

- Slim-design transformer
- 2 pole USA plug
- Input: 90-264VAC Output: 24VDC 60W
- Mates to HLS Under Mount LED Task Lights

Model  
E164

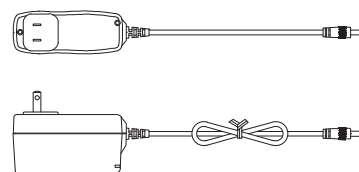



Along with our casework and fume hoods, Hanson can supply you with all the accessories and materials you need to complete your laboratory installation, including your counter tops, sinks, service fixtures, electrical fixtures, pegboards and drying racks.

**Don't see what you need? Just contact your HLS representative.**

## Laboratory Accessories Index

Page

*Everything you need to complete your lab.*

<b>LABORATORY SERVICE FIXTURES</b> .....	114
• Faucets .....	114
• Foot Controls, Goosenecks, Handles .....	116
• Needle Valves .....	117
• Ball Valves .....	118
• Eye Washes .....	119
<b>SINKS AND ACCESSORIES</b> .....	121
• Epoxy Resin & Polypropylene Sinks .....	121
• Stainless Steel Sinks; Cup Sinks .....	122
• Sink Strainers; Sink Mount Kits .....	123
<b>ELECTRICAL FIXTURES</b> .....	124
• Pedestals and Power Strips .....	124
<b>PEGBOARDS</b> .....	125
<b>DRIP TRAYS, SOAP/TOWEL DISPENSERS</b> .....	126
<b>COUNTERTOPS / WORK SURFACES</b> .....	127



# LABORATORY FIXTURES & ACCESSORIES

## Service Fixtures – Faucets

### Single Faucet - Counter Mount

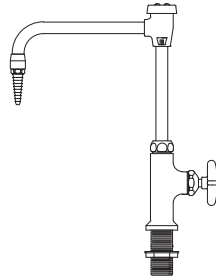

L614-8VB 

Counter mounted cold water vacuum breaker gooseneck faucet. Chrome plated brass with 8" spread rigid / swing gooseneck. Removable straight serrated hose connector.

### Distilled Water Faucets

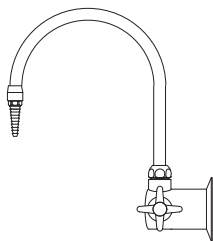

L2784-8WS

Chrome Plated - Tin Lined

Right hand curb mounted distilled water faucet. Chrome plated brass with a hot tin lined interior. It has a self-closing handle and disc type valve with a renewable interior assembly. The 8" spread rigid / swing gooseneck has a removable straight serrated hose connector.

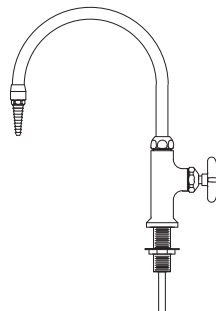

L684-8

Chrome Plated - Tin Lined

Deck mounted distilled water gooseneck faucet. Chrome plated brass with a hot tin lined interior. It has a self-closing handle and disc type valve with a renewable interior assembly. The 8" spread rigid / swing gooseneck has a removable straight serrated hose connector.

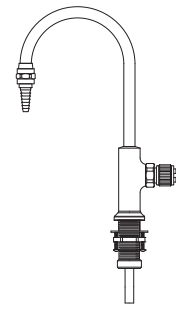

L7853 

Chrome Plated - Polypropylene Lined

Right hand deck mounted distilled water faucet. Profax natural polypropylene material. Standard 3/8" female NPT inlet connection. Molded serrated outlet fitting connects to different tubing sizes. Full flow at 1 full turn. 6" spread rigid gooseneck.

### Mixing Faucets - Counter Mount

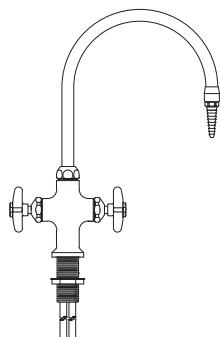

L414-8

Counter mounted hot and cold mixing gooseneck faucet. Chrome plated brass with an 8" spread rigid / swing gooseneck. Removable straight serrated hose connector.

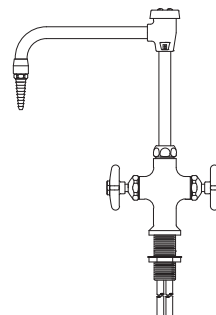

L414-8VB 

Counter mounted hot and cold mixing vacuum breaker gooseneck faucet. Chrome plated brass with an 8" spread rigid / swing gooseneck. Removable straight serrated hose connector.

### Mixing Faucets - Curb Mount / Wall Mount

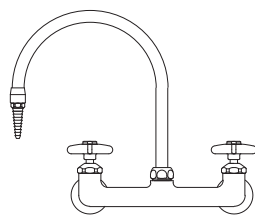

L514-8WSA

Curb mounted hot and cold water mixing gooseneck faucet. Made of chrome plated brass with an 8" spread rigid / swing gooseneck. Removable straight serrated hose connector. Valves are disc type with renewable internal assemblies. Flanged inlets are complete with 3/8" I.P.S. tank nipples, locknuts and washers on 8" centers.

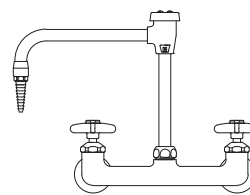

L514-8VB-WSA

Curb mounted hot and cold water mixing vacuum breaker gooseneck faucet. Made of chrome plated brass with an 8" spread rigid / swing gooseneck. Removable straight serrated hose connector. Valves are disc type with renewable internal assemblies. Flanged inlets are complete with 3/8" I.P.S. tank nipples, locknuts

# LABORATORY FIXTURES & ACCESSORIES

## Service Fixtures – Foot Controls, Gooseneck, Handles

### Foot Controls

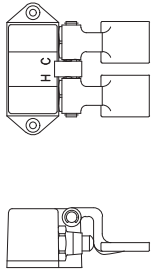

L3001

Floor mounted foot control double pedal mixing valve is chrome plated brass. Has twin pedals with self-closing valves for mixing hot and cold water.

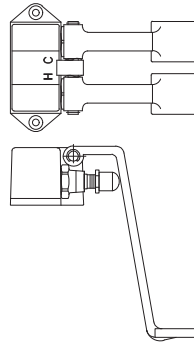

L3001LP

Cabinet mounted foot control double pedal mixing valve is chrome plated brass. Has twin pedals with self-closing valves for mixing hot and cold water.

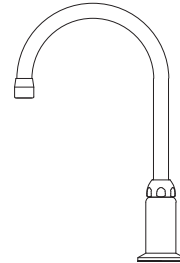

L084-8WSA

Deck mounted water gooseneck fitting is chrome plated brass. Consisting of a 8" spread rigid / swing gooseneck with mounting flange. Intended for use as an outlet for L3001.

### BH - Wrist Blade Handles

4" wrist blade handle can be supplied for water faucet in lieu of four-armed or lever handles when specified. The 4" long handle is chrome plated. ADA compliant. To specify wrist blade handles add -BH at the end of the water faucet model number.

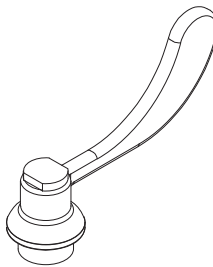

### Laboratory Needle Valves

(for use with Air, Vacuum, or Gases - not to be used for Liquids, Steam, or Oxygen)

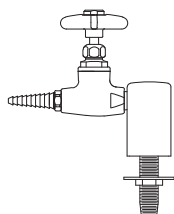

L2880-131WSA-\_\_  
Single

Gas, Air, or Vacuum deck mounted fitting is chrome plated brass. Consists of a single outlet turret with a laboratory needle valve. Complete with a 3/8" I.P.S. tank nipple, locknut, and washer. SPECIFY SERVICE DESIRED.

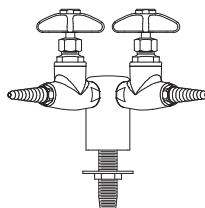

L2880-132-AWSA-\_\_  
90° Double

Double Gas, Air, or Vacuum deck mounted fitting. Same as L2880-131WSA except consists of a 2-way 90° outlet turret and two laboratory needle valves. Complete with a 3/8" I.P.S. tank nipple, locknut, and washer. SPECIFY SERVICE DESIRED.

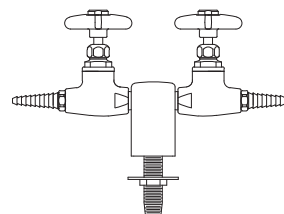

L2880-132SWSA-\_\_  
180° Double

Double Gas, Air, or Vacuum deck mounted fitting. Same as L2880-131WSA except consists of a 2-way 180° outlet turret and two laboratory needle valves. Complete with a 3/8" I.P.S. tank nipple, locknut, and washer. SPECIFY SERVICE DESIRED.

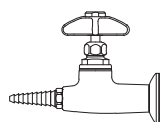

L4880FT-325-\_\_  
Single

Gas, Air, or Vacuum fitting (curb or panel mounted). Chrome plated brass. Consists of a single outlet, panel flange, and laboratory needle valve. SPECIFY SERVICE DESIRED

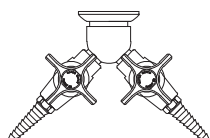

L2880-141FT-\_\_  
90° Double

Double Gas, Air, or Vacuum fitting (curb or panel mounted). Chrome plated brass. Consists of two-way 90° outlet, panel flange, and two laboratory needle valves. SPECIFY SERVICE DESIRED.

#### NEEDLE VALVE SERVICE FITTINGS

All service fittings shown are Standard Control needle valves not intended for use with high purity gases. For fine control needle valves or high purity needle valves contact your HLS representative

Standard Control needle valves are rated up to 150psi working pressure and have a metering control of two full handle revolutions from closed to fully open.

Fine Control needle valves are rated up to 250psi working pressure and have a metering control of six full handle revolutions from closed to fully open.

*Contact your HLS representative for specifying needle valve service fittings.*

# LABORATORY FIXTURES & ACCESSORIES

## Service Fixtures – Ball Valves

### Laboratory Ball Valves

(for use with Air, Vacuum, or Gases - not to be used for Liquids, Steam, or Oxygen)

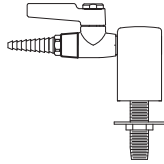

L4200-131WSA-\_\_  
Single

Gas, Air, or Vacuum deck mounted fitting is chrome plated brass. Consists of a single outlet turret with a laboratory ball valve. Complete with a 3/8" I.P.S. tank nipple, locknut, and washer. SPECIFY SERVICE DESIRED.

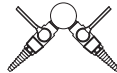
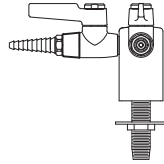

L4200-132-AWSA-\_\_  
90° Double

Double Gas, Air, or Vacuum deck mounted fitting. Same as L2880-131WSA except consists of a 2-way 90° outlet turret and two laboratory ball valves. Complete with a 3/8" I.P.S. tank nipple, locknut, and washer. SPECIFY SERVICE DESIRED.

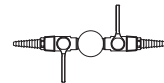
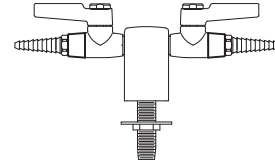

L4200-132SWSA-\_\_  
180° Double

Double Gas, Air, or Vacuum deck mounted fitting. Same as L2880-131WSA except consists of a 2-way 180° outlet turret and two laboratory ball valves. Complete with a 3/8" I.P.S. tank nipple, locknut, and washer. SPECIFY SERVICE DESIRED.

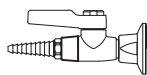

L4200-158-FT-\_\_  
Single

Gas, Air, or Vacuum fitting (curb or panel mounted). Chrome plated brass. Consists of a single outlet, panel flange, and laboratory ball valve. SPECIFY SERVICE DESIRED

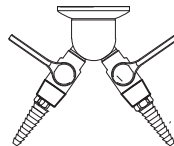

L4200-141FT-\_\_  
90° Double

Double Gas, Air, or Vacuum fitting (curb or panel mounted). Chrome plated brass. Consists of two-way 90° outlet, panel flange, and two laboratory ball valves. SPECIFY SERVICE DESIRED.

#### Service Fitting Color Code:

Air.....	Orange
Cold Water.....	Dark Green
Distilled Water.....	White
Gas.....	Dark Blue
Hot Water.....	Red
Argon.....	Violet
Nitrogen.....	Brown
Oxygen.....	Light Green
Special Gases.....	Light Blue
Steam.....	Black
Vacuum.....	Yellow
CO2.....	Pink
Hydrogen.....	Pink

### Emergency Eye Wash

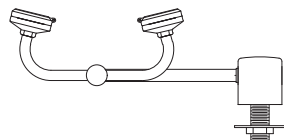

EW805

Right hand sided sink-top mounted eyewash. Spray heads swivel 90 degrees from storage to operational position. Water flow is activated by swinging arm over sink. Each spray head has a "flip top" dust cover, internal flow control, and filter to remove impurities from the water flow. Chrome-plated brass stay-open ball valve. 1/2" NPT male inlet. Furnished with locknut and washer for securing to countertop.

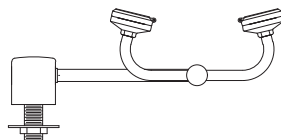

EW805LH

Left hand sided sink-top mounted eyewash. Spray heads swivel 90 degrees from storage to operational position. Water flow is activated by swinging arm over sink. Each spray head has a "flip top" dust cover, internal flow control, and filter to remove impurities from the water flow. Chrome-plated brass stay-open ball valve. 1/2" NPT male inlet. Furnished with locknut and washer for securing to countertop.

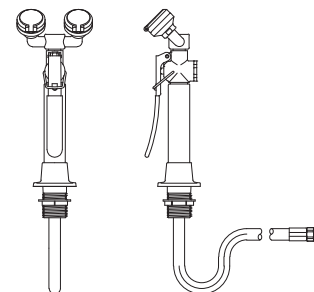

EW1022

Deck mounted dual purpose eye wash / drench hose with two gentle spray outlet heads angled at 45° and squeeze valve with locking clip. Flange, shank, and locknut for attaching to table top are included. 3/8" I.P.S. male thread swivel inlet.

EW1020

Deck mounted dual purpose eye wash / drench hose. Same as above except with one gentle spray outlet head.

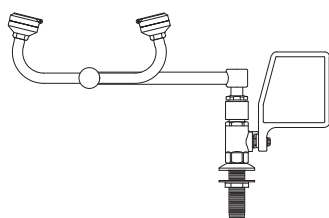

EW806

Right hand sided sink-top mounted eyewash. Spray heads swivel 90 degrees from storage to operational position. Water flow is activated by flag handle. Each spray head has a "flip top" dust cover, internal flow control, and filter to remove impurities from the water flow. Chrome-plated brass stay-open ball valve. 1/2" NPT male inlet. Furnished with locknut and washer for securing to countertop.

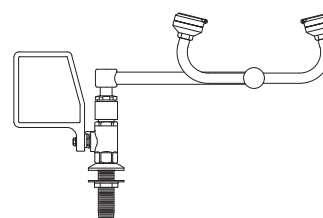

EW806LH

Left hand sided sink-top mounted eyewash. Spray heads swivel 90 degrees from storage to operational position. Water flow is activated by flag handle. Each spray head has a "flip top" dust cover, internal flow control, and filter to remove impurities from the water flow. Chrome-plated brass stay-open ball valve. 1/2" NPT male inlet. Furnished with locknut and washer for securing to countertop.

# LABORATORY FIXTURES & ACCESSORIES

## Service Fixtures – Eye Washes

### Emergency Eye Wash

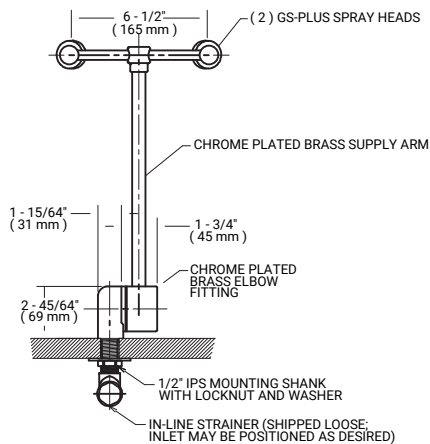
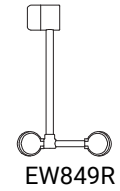
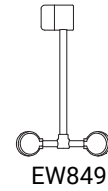
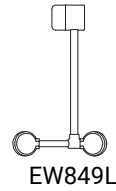
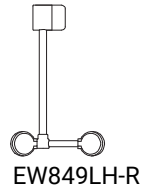
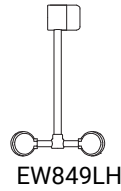
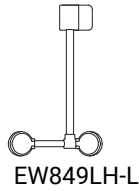

#### NOTES:

- Swinging outlet head assembly down 96 degrees from vertical to horizontal position activates water flow
- Each gs-plus spray head has a "flip-top" dust cover, internal flow control and filter to remove impurities from the water flow
- Unit mounts into countertops up to 1-1/2" thick, base of unit has pins to prevent unit from turning on counter
- Unit is furnished with in-line strainer to protect spray heads and valve components from debris in water line
- Valve begins to open at "activation point" shown above

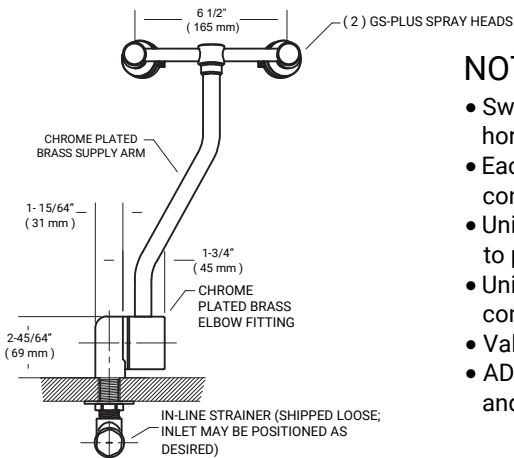
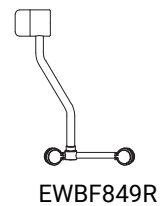
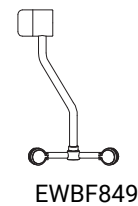
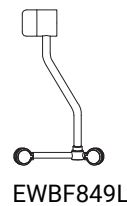
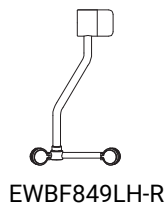
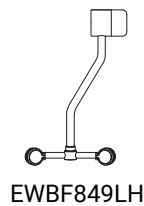
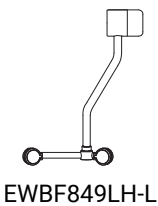

#### NOTES:

- Swinging outlet head assembly down 96 degrees from vertical to horizontal position activates water flow.
- Each gs-plus spray head has a "flip-top" dust cover, internal flow control and filter to remove impurities from the water flow.
- Unit mounts into countertops up to 1-1/2" thick. base of unit has pins to prevent unit from turning on counter.
- Unit is furnished with in-line strainer to protect spray heads and valve components from debris in water line.
- Valve begins to open at "activation point" shown above.
- ADA compliance is dependent on 27" knee clearance under counter and 34" max. counter height.



### Drop-In Epoxy Sinks

- Epoxy resin sinks are molded with coved corners with the bottom pitched to the drain outlet
- They are recessed mounted into the work surface
- Undermount epoxy sinks are also available
- Contact your HLS representative for information on additional sizes and styles available

### Model numbers suggested to be used with Epoxy tops

Model	Inside			Outside			Drain		Outlet
	A	B	C	D	E	F	G	H	
D30	18.0	15.0	11.0	19.6	16.6	11.9	3.5	3.5	Corner
D55	25.0	15.0	10.0	26.6	16.6	11.0	4.5	4.5	Corner
D59	28.0	15.0	11.8	29.7	16.7	12.5	4.5	4.5	Corner
ADA Compliant Sinks									
A25	18.0	15.0	5.0	19.6	16.6	5.8	3.5	3.5	Corner
A26	18.0	15.0	5, 11	19.6	16.6	12.0	5.5	4.5	Corner
A55	25.0	15.0	4.8	26.6	16.6	5.8	3.5	3.5	Corner
A56	25.0	15.0	5, 11	26.7	16.6	11.9	4.5	4.5	Corner



### "-S" Model numbers suggested to be used with Phenolic tops

Model	Inside			Outside			Drain		Outlet
	A	B	C	D	E	F	G	H	
D30-S	18.0	15.0	11.0	19.6	16.6	11.9	3.5	3.5	Corner
D55-S	25.0	15.0	10.0	26.6	16.6	11.0	4.5	4.5	Corner
D59-S	28.0	15.0	11.8	29.7	16.7	12.5	4.5	4.5	Corner
ADA Compliant Sinks:									
A25-S	18.0	15.0	5.0	19.6	16.6	5.8	3.5	3.5	Corner
A55-S	25.0	15.0	5.1	26.6	16.6	5.4	3.9	3.9	Corner

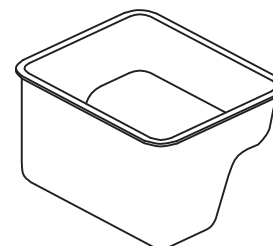

A26 & A56 Tiered ADA Drop-In Sink

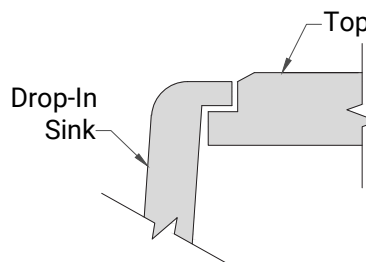
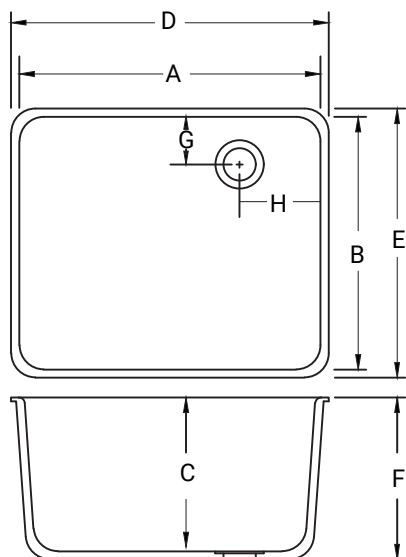

# LABORATORY FIXTURES & ACCESSORIES

## Stainless Steel Sinks; Cup Sinks

### Stainless Steel Sinks

- Sinks are manufactured with seamless die-drawn construction in Type 304, 18 ga. stainless steel
- Fully coated underside insulates for sound deadening and reduces condensation
- Other stainless sink options are available including:
  - Sinks with faucet ledges
  - Sinks with faucet ledges
  - ADA compliant sinks
  - Different sizes, shapes, and styles, including under mount sinks
  - Type 316 stainless steel sinks
  - Stainless steel sink tables with drainboards



For additional information, contact your HLS representative

### Single Bowl

Model	Inside		Outside		Depth
	A	B	C	D	
S-1719-A-GR	14	16	17	19	7-1/2
SX-1719-A-GR	14	16	17	19	10-1/2
S-1925-A-GR	16	22	19	25	7-1/2
SX-1925-A-GR	16	22	19	25	10-1/2

#### ADA Compliant Sinks

S-ADA-1719-A-GR	14	16	17	19	5-1/2
-----------------	----	----	----	----	-------

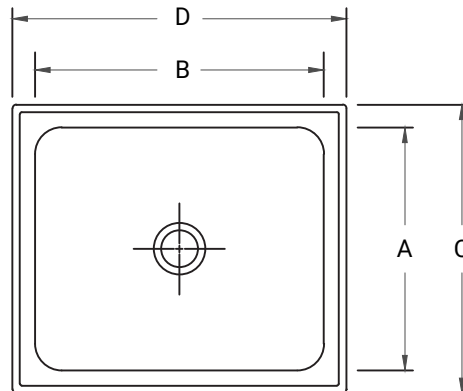

### Double Bowl

Model	Inside		Outside		Depth
	A	B	C	D	
D-1933-A-GR	14	16	19	33	7-1/2
DX-1933-A-GR	14	16	19	33	10-1/2



### Cup Sinks

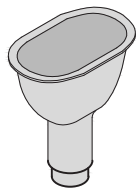

CS4R

Black Polypropylene. Complete with removable strainer. 6"x3" inside dimension. 1 1/2" I.P.S. male straight thread outlet. (Overall height is 7 1/2")



TS12

Black Polypropylene. Complete with removable strainer. 9"x3" inside dimension. 1 1/2" I.P.S. male straight thread outlet. (Overall height is 7")

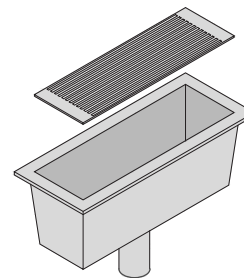

TS18

Black Epoxy. Complete with removable type 316 stainless steel wire screen. 13 3/8" x 4 1/8" x 5 1/4" I.D. 1 1/2" I.P.S. male straight thread outlet.

### Strainer - Epoxy sink applications

#### SO3-R

Black Polypropylene sink outlet. Complete with locknut and disc strainer.

1 1/2" BSP male straight thread outlet.

For use with epoxy resin tub sinks and troughs.

Model applications:

D30

D55

D59

A25

A55

A56

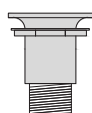

#### S504-B

Black Polypropylene sink outlet. Complete with locknut and disc strainer.

1 1/2" BSP male straight thread outlet.

For use with "-S" epoxy resin tub sinks and troughs.

Model applications:

D30-S

D55-S

D59-S

A25-S

A55-S



### Strainer - stainless steel sink applications

Strainers have a 1-1/2" O.D. diameter tailpiece

Model	Description
J-35	Stainless Steel Crumb Cup Strainer with a removable locking basket for use with Just Mfg. sinks
LK99	Stainless Steel Body Strainer Basket Rubber Seal for use with Elkay sinks



J-35



LK99

### Undermount Sink mounting kits

Model	Description
K10760-18	HARDWARE KIT, UNDERMOUNT SINK, 18" SINK CABINET
K10760-24	HARDWARE KIT, UNDERMOUNT SINK, 24" SINK CABINET
K10760-30	HARDWARE KIT, UNDERMOUNT SINK, 30" SINK CABINET
K10760-35	HARDWARE KIT, UNDERMOUNT SINK, 35" SINK CABINET
K10760-42	HARDWARE KIT, UNDERMOUNT SINK, 42" SINK CABINET
K10760-47	HARDWARE KIT, UNDERMOUNT SINK, 47" SINK CABINET
K10760-52	HARDWARE KIT, UNDERMOUNT SINK, 52" SINK CABINET
K10760-58	HARDWARE KIT, UNDERMOUNT SINK, 58" SINK CABINET

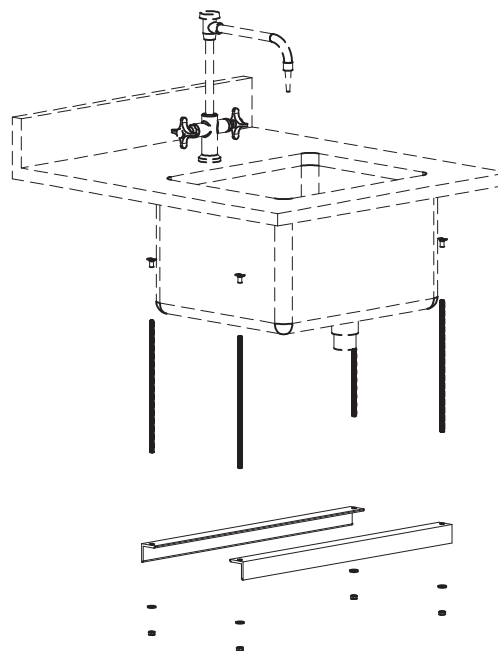

# LABORATORY FIXTURES & ACCESSORIES

## Pedestals & Power Strips

### Electrical Pedestals

- Pedestal monuments are furnished with a choice of three finishes. Available finishes are:
  - Wrinkle Black Epoxy  
Cast aluminum boxes are powder coated with a wrinkle black epoxy coating. The coating has a matte finish.
  - Satin (Brushed) Aluminum  
Cast aluminum boxes are polished to remove the rough cast surface. Boxes have an attractive brushed finished. To order, add suffix "SA" to model number.
  - Polished (Bright) Aluminum  
Cast aluminum boxes are polished and buffed to a chrome-like surface finish. To order, add suffix "PB" to model number.
- All electrical pedestals are UL-listed
- Includes mounting shank and nut
- Contact your HLS representative for additional information.

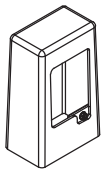

#### Single Pedestal Single Sided

Model	Finish
E300WS	Wrinkle Black Epoxy
E300SA-WS	Satin (Brushed) Aluminum
E300PB-WS	Polished (Bright) Aluminum

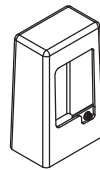

#### Single Pedestal Double Sided

Model	Finish
E400WS	Wrinkle Black Epoxy
E400SA-WS	Satin (Brushed) Aluminum
E400PB-WS	Polished (Bright) Aluminum

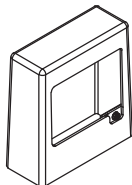

#### Double Pedestal Single Sided

Model	Finish
E500WS	Wrinkle Black Epoxy
E500SA-WS	Satin (Brushed) Aluminum
E500PB-WS	Polished (Bright) Aluminum

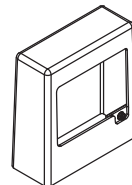

#### Double Pedestal Double Sided

Model	Finish
E600WS	Wrinkle Black Epoxy
E600SA-WS	Satin (Brushed) Aluminum
E600PB-WS	Polished (Bright) Aluminum

### Power Strips

- 125 Volt, 15 amp receptacles with on / off switch and circuit breaker. UL listed. Attachment brackets are included. 6 ft. or 15 ft. cord length. Color: Gray.

Model	Outlets	Length	Cord Length
E133	8	24"	6'
E134	12	36"	15'
E136	8	48"	6'
E137	20	60"	15'

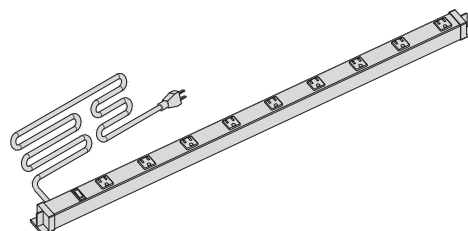

### Pegboards

- Pegboards can be ordered in a variety of materials and are used to dry glassware and other lab items
- Epoxy resin and Phenolic resin pegboards are black
- Acrylic pegboards are clear (white color optional)
- Each pegboard includes 6" long, angled white pegs
- Other pegboard sizes are available
- Contact your HLS representative for additional information

### Finished Backs

- Used to finish the back of epoxy resin or stainless steel pegboard when the back will be exposed to view
- Phenolic resin and acrylic pegboards are prefinished and do not require finished backs
- To order a finished back, add -FB to the end of the model number

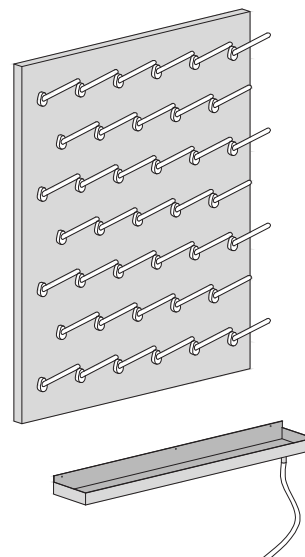

### Acrylic Pegboards

Model	Size	Pegs
APB-1824	18"W x 24"H	18
APB-2424	24"W x 24"H	25
APB-2430	24"W x 30"H	32
APB-3030	30"W x 30"H	41
APB-3036	30"W x 36"H	50

### Epoxy Resin Pegboards

Model	Size	Pegs
EPB-1824	18"W x 24"H	21
EPB-2424	24"W x 24"H	28
EPB-2430	24"W x 30"H	39
EPB-3030	30"W x 30"H	46
EPB-3036	30"W x 36"H	56

### Phenolic Resin Pegboards

Model	Size	Pegs
PPB1824	18"W x 24"H	18
PPB2424	24"W x 24"H	25
PPB2430	24"W x 30"H	32
PPB3030	30"W x 30"H	41
PPB3036	30"W x 36"H	50

### Stainless Steel Pegboards

Includes integral drip tray with a drainage tube.

Model	Size	Pegs	Drip Tray
V1824	18"W x 24"H	15	4"
V2424	24"W x 24"H	20	4"
V2424-2	24"W x 30"H	32	2"
V2430	24"W x 30"H	32	4"
V2430-2	30"W x 30"H	50	2"
V3030	30"W x 30"H	50	4"
V3036	30"W x 36"H	40	4"

# LABORATORY FIXTURES & ACCESSORIES

## Pegboards. Drip Trays, Soap/Towel Dispensers

### Pegboards

- Acrylic pegboards are clear (white color optional) and include 6" long, angled white pegs
- Contact your HLS representative for additional information

#### Acrylic Pegboards with Half Pegs and Drip Tray

Model	Size	Pegs
APB-4830LP-ASY	48"W x 30"H	25
APB-4830RP-ASY	48"W x 30"H	25
APB-4830LP-PTD-ASY <i>(mounting for right-side paper towel dispenser)</i>	48"W x 30"H	25
APB-4830RP-PTD-ASY <i>(mounting for left-side paper towel dispenser)</i>	48"W x 30"H	25

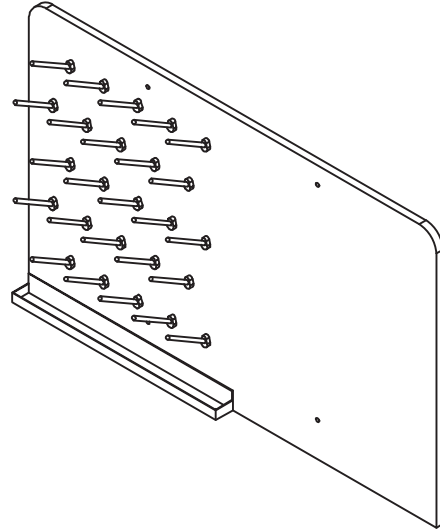

### Drip Trays

- Drip trays mount at the front of Phenolic, Epoxy, or Acrylic pegboards with a drainage tube

Model	Size
FDT-18-2	18"W x 2"D
FDT-24-2	24"W x 2"D
FDT-30-2	30"W x 2"D

### Pegboard Support Brackets

- Painted steel brackets for mounting pegboards to counter tops
- Finished back panel required for mounting to pegboard

Model	Quantity
FSA	1 PAIR

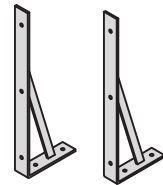

### Paper Towel Dispenser

Model	Size
B-262	10-3/4" W x 14" H x 4" D
B-2620	10-3/4" W x 14" H x 4" D
B-2621	10-3/4" W x 7-1/8" H x 4" D
B-4262	10-3/16" W x 13-1/2" H x 4-7/8" D
B-526	12-3/4" W x 11-5/16" H x 6" D (Countertop Mount)

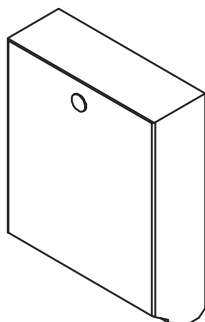

### Soap Dispenser

Model	Size
B-2012	4-3/16" W x 9-9/16" H x 4-7/32" D
B-2111	4-3/4" W x 8-1/8" H x 3-1/2" D
B-2112	8-1/8" W x 4-3/4" H x 3-1/2" D

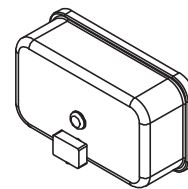

- Work surfaces are available in a number of different materials. Choosing the correct type of laboratory top depends on the intended applications, appropriate to the type of work performed and chemicals that are used in your laboratory.
- HLS can recommend and furnish work surfaces fabricated to your size requirements complete with the appropriate sinks, drains, and accessories.
- Contact your HLS representative for additional information on material choices, colors, and styles.

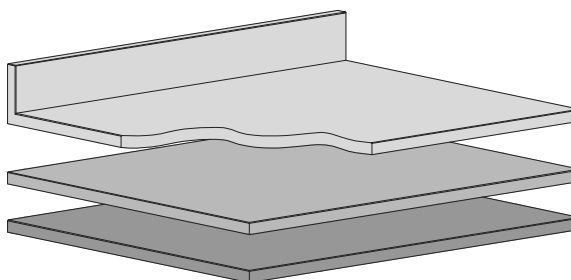

### Work Surface Materials

MATERIAL	APPEARANCE	COMPOSITION	APPLICATIONS / CHEMICAL RESISTANCE
PHENOLIC RESIN 	A smooth, hard non-glare surface usually provided in 1" thick flat surfaces. 3/4" thick tops are also available. Back splashes are field applied.	Cellulose fiber reinforced phenolic core with polyurethane co-polymer surface.	Good chemical resistance to a wide range of acids and solvents. A very versatile material that can be used in most general laboratory applications and work surfaces.
EPOXY RESIN	An ultra-smooth, hard non-glare surface usually provided in 1" thick surfaces. Flat or marine edges are available. Back splashes are field applied.	A non-porous work surface molded from a compound epoxy and inert fillers mixture cured into monolithic sheets.	Excellent durability and chemical resistance to a wide range of acids and solvents. Used wherever optimum physical and chemical resistant properties are required.
LAMINATED PLASTIC	A smooth, hard surface usually provided in 1" thick surfaces. Flat or raised edges are available.	High pressure melamine sheets laminated onto a wood particle board core. Various materials are used for edges of counter tops.	A fair resistance to chemicals recommended for light duty work surface areas. Laminate is a good choice for shelving applications. Higher chemical resistant laminates are also available.
STAINLESS STEEL	A smooth, hard polished steel surface usually provided in 1" thick surfaces. Flat or marine edges are available. Sinks can be integrally welded into the work surface. Back splashes are usually provided with coved integral splashes.	Stainless steel work surfaces are usually manufactured with 16 ga., type 304 stainless steel, welded and polished to a #4 finish. Type 316 stainless steel is also available for higher rust and chemical resistance.	Stainless steel provides a good chemical resistant non-porous surface. Recommended for very sterile areas such as food prep and extremely wet areas such as glassware washing rooms.

# FUME HOODS

## Index

Benchtop and floor-mounted, standard or custom, and the fastest delivery in the U.S. The best is within your reach, your budget, and your schedule.

Hanson's hoods have one of the smoothest riding sashes in the industry at surprisingly competitive prices. Many of Hanson's standard design features are expensive options with other fume hood manufacturers.



## Fume Hood Index

Page

*Benchtop, floor-mounted, and custom configurations, with the fastest fume hood shipping times in the industry*

<b>ABOUT HLS FUME HOODS</b> .....	129
<b>SASH DESIGNS</b> .....	130
<b>OPERATING TYPES</b> .....	132
<b>5SA SERIES – BENCHTOP MOUNT</b> .....	133
• Dimensional Data .....	133
• General Purpose Hoods .....	134
• Hi-Line Hoods .....	135
• ADA Hoods .....	136
<b>4SA SERIES – FLOOR-MOUNT</b> .....	137
• Dimensional Data .....	137
• Vertical Sash .....	138
• Horizontal Sash .....	139
<b>OPTIONS AND ACCESSORIES</b> .....	140
• Base Cabinets .....	140
• Service Fixtures .....	141
• Countertops .....	142
• Electrical, Cupsinks, Lighting .....	143
• Flow Monitors, Lattice Rod Assemblies .....	144
• Ceiling Enclosures .....	145
• Extractor Arms .....	148
• Canopy Hoods .....	149

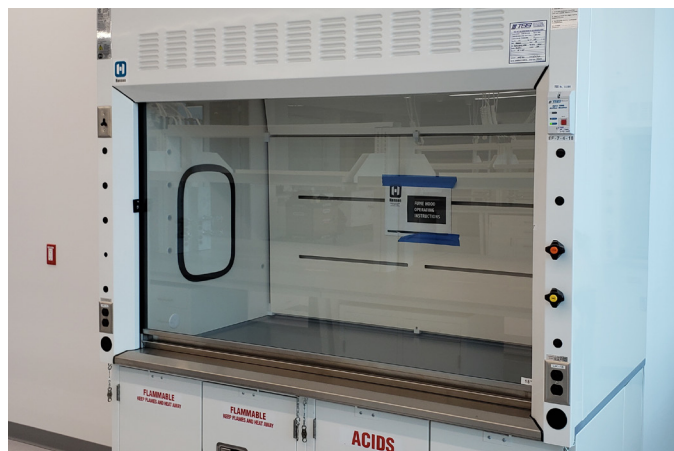



### The HLS Advantage.....

With a 50-year history of dedication and experience in the laboratory market, Hanson Lab Solutions delivers a unique new generation of fume hoods, incorporating design excellence and superior safety and performance. Many of Hanson's standard design features are expensive options with other fume hood manufacturers. HLS hoods have been tested to ASHRAE-110-1995 specifications and are UL 1805 Listed, as manufactured.

## Features and Benefits

### Optimal View Sash Design

36" high safety glass gives you an optimal unobstructed sight line into the fume hood.

### Optimal Sash Opening

30" full vertical sash opening for easier setup of lab processes and apparatus.

### Stainless Steel Bottom Air Foil

Standard stainless steel flush sill bottom air foil gives you superior corrosion resistance than ordinary painted sills.

### Stainless Steel Vented Finger Pull

Standard stainless steel vented sash finger pull provides a smooth sash operation and corrosion resistance.

### Outer Access Panels

Removable side access panels on both sides provide easy access for maintenance and for adding additional service fixtures in the future.

### Stainless Steel Faceplates

Stainless steel electrical plates, instead of plastic, are provided on electrical switches and receptacles as standard.

### Junction Box Receptacle

A standard duplex receptacle is provided on the junction box with prewiring of electrical fixtures.

### Stainless Steel Exhaust Collar

A standard stainless steel exhaust collar in lieu of a painted collar is provided for superior corrosion resistance from chemical fumes.

### Exterior LED Lighting

Exterior LED lighting is located away from fumes and gives you excellent interior illumination.

### Mechanical Sash Stop

Designed to stop the fume hood sash from rising above a certain point. The stop can be overridden to allow the sash to fully open when needed to set up equipment inside the hood. Unless otherwise specified, the stop will be mounted on the left side, at an 18" sash opening.

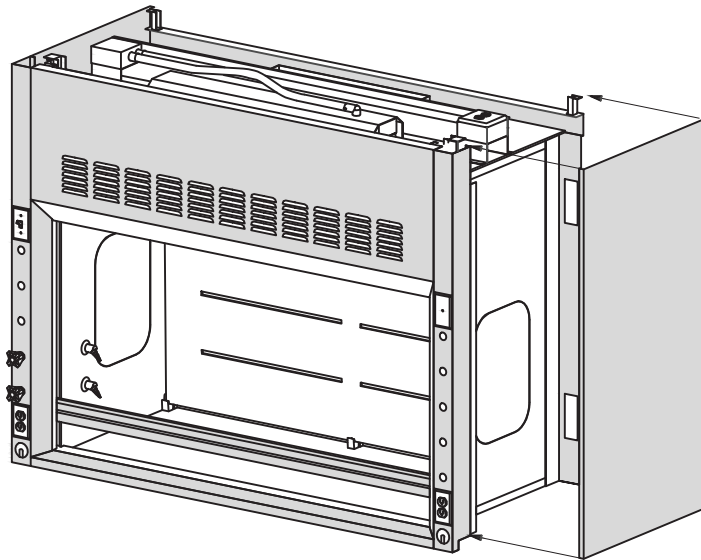

### Interior Access Panels

PVC soft-gasket interior access panels on both sides eliminate containment seepage into sidewalls.

### Wire Management Chase

Our standard wire management chase system, exclusive on Hanson's benchtop fume hoods, allows you to run cords or tubing into the hood instead of under the glass sash.

### Full-Frame Construction

Interior and exterior panels are attached to a full-perimeter epoxy powder-coated steel frame for strength and durability.

### Service Fixtures

Unique streamlined Color-Tech service fixtures are epoxy-coated and color-coded to each type of fixture required.

# FUME HOODS

## Sash Designs

### Vertical Rising Sash

- Standard feature on HLS Benchtop and Floor-Mounted hoods
- Frameless sash with laminated safety glass and vented finger pull
- 30-1/2" high sash opening with a 36" high sight line
- Stainless steel flush sill bottom air foil
- NOTE: Hoods wider than 94" will feature a Split Sash (-SPS; see below)

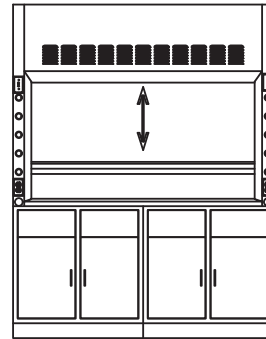

### Combination Sash - Horizontal / Vertical (optional)

- Incorporates both a vertical rising sash and a horizontal sliding sash.
- Check with your HLS representative to see how many horizontal panels are provided with each size fume hood
- To specify a combination sash design, add -CS at the end of the fume hood model number

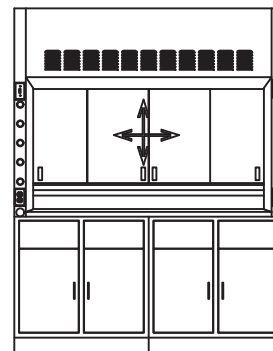

Model

-CS

### SPS - Split Sash (optional)

- Two independent vertical sashes open on a post-less track design
- To specify a split sash, specify -SPS at the end of the fume hood model number
- Maximum sash opening on Split-Sash fume hoods is 28"
- ONLY AVAILABLE ON 70, 94", 120", & 144" FUME HOODS

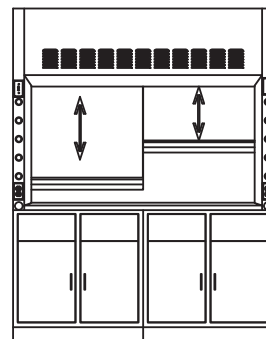

Model

-SPS

### HS - Horizontal Sliding Sash (optional)

- Uses sliding horizontal sash panels instead of vertical rising panels
- Check with your HLS representative to see how many horizontal panels are provided with each size fume hood
- To specify a horizontal sash, add -HS at the end of the fume hood model number

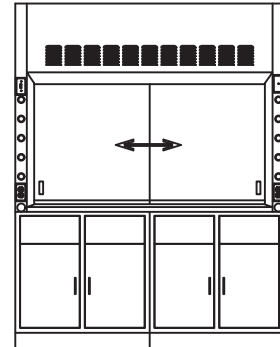

Model  
-HS

# FUME HOODS

## Operating Types

- Constant Air Volume - Standard HLS configuration
  - Designed for constant rate of exhaust
- Variable Air Volume (specify -VAV at the end of the hood part number ex. 5SA70B-VAV)
  - Designed to limit the bypass area, typically used in conjunction when VAV exhaust systems are installed on the building's HVAC system
  - VAV is a type of fume hood exhaust system that typically maintains constant fume hood face velocity by adjusting blower motor speed or a balance damper in response to changes in the sash position

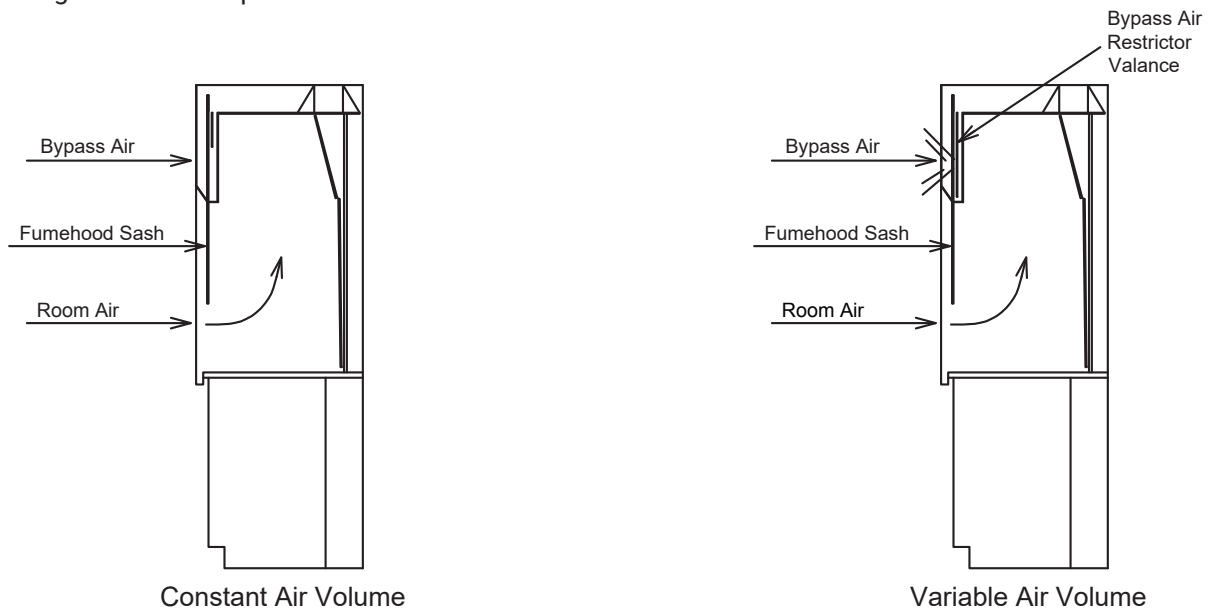

# FUME HOODS – 5SA SERIES: BENCHTOP MOUNT



## Dimensional Data

hansonlab.com • 805-498-3121

- Fume hoods are shown with HLS standard construction.
- Fume hood standard electrical package is shown with optional factory prewiring to a junction box located on the top of the hood
- A complete selection of options and accessories are located in the HLS fume hood section
- Contact your HLS representative for custom designs or other fume hood information

The dimensions shown are for the following 5SA Series fume hoods:

- General Purpose Bench Top Hoods
- Hi-Line Bench Top Hoods
- ADA Bench Top Hoods

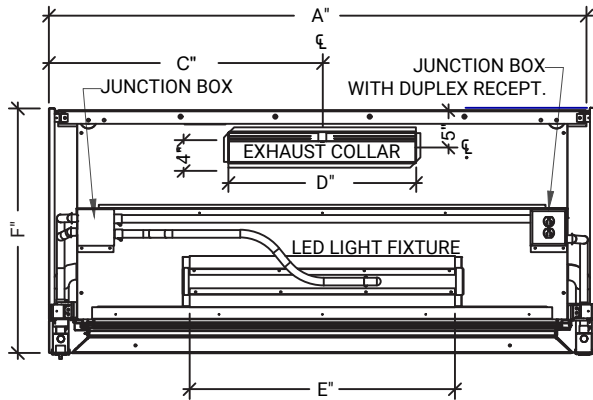

Top View

5SA Series Dimensional Chart

Model	A	B	C	D	E
5SA47A	47"	37"	23.5"	24"	24"
5SA58A	58"	48"	29"	24"	36"
5SA70A	70"	60"	35"	24"	36"
5SA94A	94"	84"	47"	36"	24" x 2
5SA120A	120"	110"	*2@31.8"	24" x 2	36" x 2
5SA47B	47"	37"	23.5"	24"	24"
5SA58B	58"	48"	29"	24"	36"
5SA70B	70"	60"	35"	24"	36"
5SA94B	94"	84"	47"	36"	24" x 2
5SA120B	120"	110"	*2@31.8"	24" x 2	36" x 2
5SA47C	47"	37"	23.5"	24"	24"
5SA58C	58"	48"	29"	24"	36"
5SA70C	70"	60"	35"	24"	36"
5SA94C	94"	84"	47"	36"	24" x 2
5SA120C	120"	110"	*2@31.8"	24" x 2	36" x 2

\*Center line of collars from either end

Model	F	G	H	I	J
5SA-A	31-3/8"	25-7/8"	23-1/2"	22"	19-1/2"
5SA-B	37-3/8"	31-7/8"	29-1/2"	28"	25-1/2"
5SA-C	41-3/8"	35-7/8"	33-1/2"	32"	29-1/2"

Note: "G" dimensions represent the water service fixture for cup sinks located at the back.

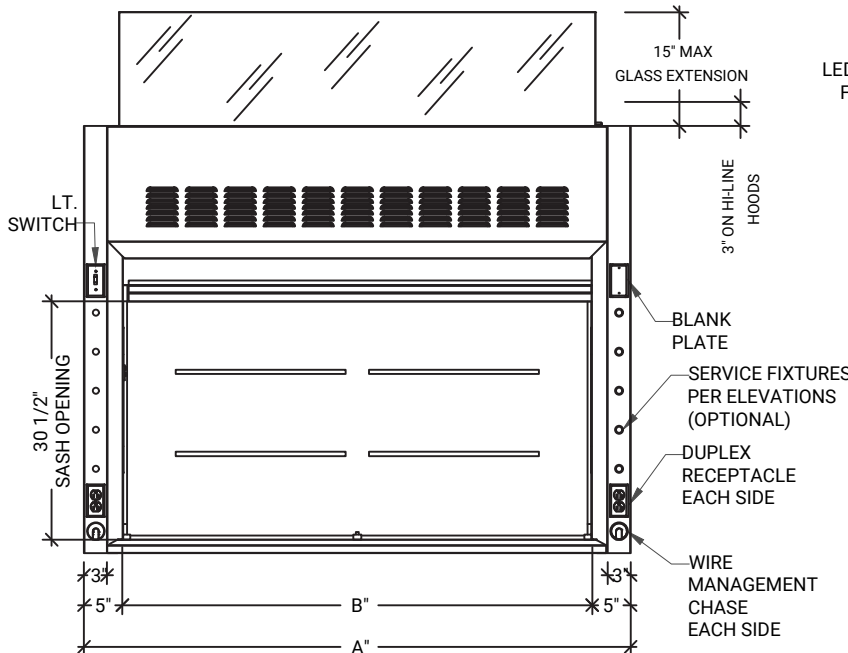

Front View

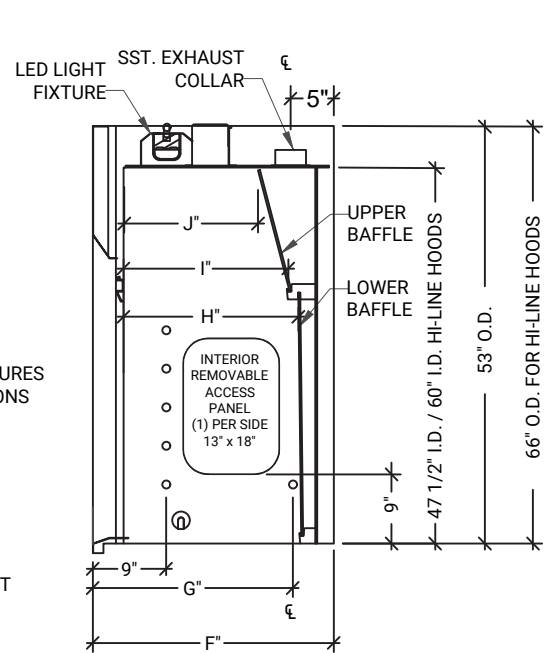

End View

# FUME HOODS – 5SA SERIES: BENCHTOP MOUNT

## General Purpose

### Constant Volume Bypass - Vertical Sash

- General purpose chemical fume hood
- Standard electrical package includes a vapor-proof LED light, light switch, and two 120V duplex receptacles
- Stainless steel flush sill bottom air foil
- 30-1/2" high sash opening with a 36" high sight line
- Frameless sash with laminated safety glass and vented finger pull
- Removable interior and exterior panels for access to service valves
- A wire management chase is provided on both sides of the fume hood
- Poly-resin glastic white interior liner
- UL 1805 Listed and meets ASHRAE 110-95 tests as manufactured

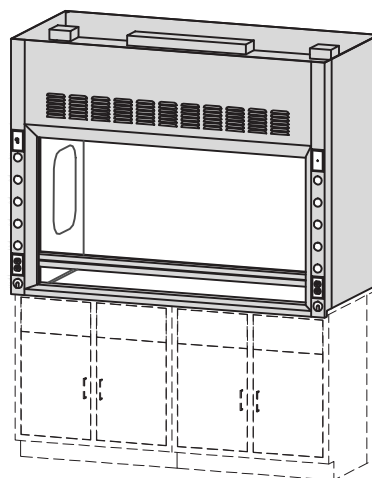

Base Cabinets are optional

#### Product Model Numbers

Width	"A" Depth 31-3/8"	"B" Depth 37-3/8"	"C" Depth 41-3/8"	Height
47"	5SA47A	5SA47B	5SA47C	53"
58"	5SA58A	5SA58B	5SA58C	53"
70"	5SA70A	5SA70B	5SA70C	53"
94"	5SA94A	5SA94B	5SA94C	53"
120"	5SA120A	5SA120B	5SA120C	53"

Note: 120" wide hoods have a split sash, with two vertical rising sash panels with a maximum 28" high sash opening.

### Fume Hood Options and Accessories

- Service Fixtures
- Hood Counter Tops and Sink
- Base and Specialty Cabinets
- Monitors / Alarms (not included on -VAV hoods)
- Ceiling Enclosures
- Pre-piping and Prewiring
- See Accessories pages for more options

### Sash Style Options

- Combination Sash -CS
- Split Sash -SPS
- Horizontal Sash -HS

### Fume Hood Types

- Variable Air Volume -VAV

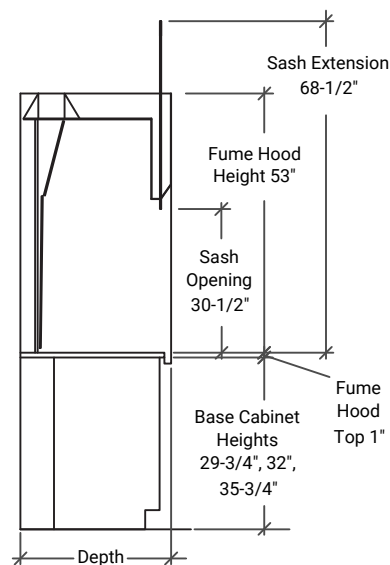

#### 5SA Series CFM Exhaust Volumes .15 S.P.

Fume Hood Width	Exhaust Collar Size	CFM @100 LFM (18" Sash Opening)	CFM @100 LFM (30-1/2" Sash Opening)
47"	4" x 24"	475	790
58"	4" x 24"	600	1020
70"	4" x 24"	750	1300
94"	4" x 36"	1050	1800
120"	(2) 4" x 24"	1400 Ⓐ	1075 Ⓑ

Ⓐ CFM is calculated with both split sashes open at 18"

Ⓑ CFM is calculated with one side of split sash fully open at 28" high

CFM = Cubic Feet Per Minute

LFM = Linear Feet Per Minute

# FUME HOODS – 5SA SERIES: BENCHTOP MOUNT



Hi-Line

hansonlab.com • 805-498-3121

## Constant Volume Bypass - Vertical Sash

- 66" high for extra interior height to accommodate apparatus up to 60" high
- Standard electrical package includes a vapor-proof LED light, light switch, and two 120V duplex receptacles
- Stainless steel flush sill bottom air foil
- 30-1/2" high sash opening with a 36" high sight line
- Frameless sash with laminated safety glass and vented finger pull
- Removable interior and exterior panels for access to service valves
- A wire management chase is provided on both sides of the fume hood
- Poly-resin glastic white interior liner
- UL 1805 Listed and meets ASHRAE 110-95 tests as manufactured

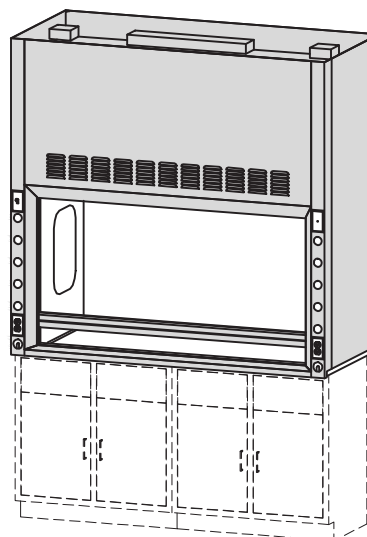

Base Cabinets are optional

### Product Model Numbers

Width	"A" Depth 31-3/8"	"B" Depth 37-3/8"	"C" Depth 41-3/8"	Height
47"	5SA47A-HL	5SA47B-HL	5SA47C-HL	66"
58"	5SA58A-HL	5SA58B-HL	5SA58C-HL	66"
70"	5SA70A-HL	5SA70B-HL	5SA70C-HL	66"
94"	5SA94A-HL	5SA94B-HL	5SA94C-HL	66"
120"	5SA120A-HL	5SA120B-HL	5SA120C-HL	66"

Note: 120" wide hoods have a split sash, with two vertical rising sash panels with a maximum 28" high sash opening.

### Fume Hood Options and Accessories

- Service Fixtures
- Hood Counter Tops and Sink
- Base and Specialty Cabinets
- Monitors / Alarms (not included on -VAV hoods)
- Ceiling Enclosures
- Pre-piping and Pre-wiring
- See Accessories pages for more options

### Sash Style Options

- Combination Sash -CS
- Split Sash -SPS
- Horizontal Sash -HS

### Fume Hood Types

- Variable Air Volume -VAV

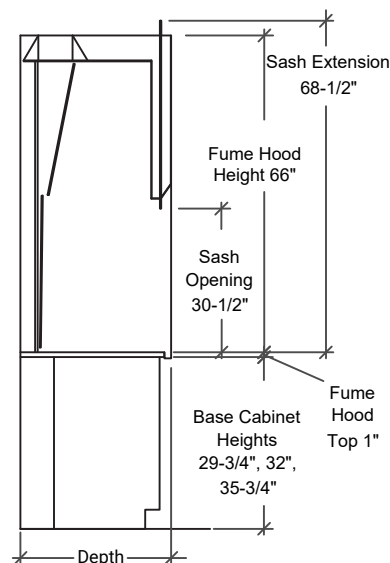

### 5SA Series CFM Exhaust Volumes .15 S.P.

Fume Hood Width	Exhaust Collar Size	CFM @100 LFM (18" Sash Opening)	CFM @100 LFM (30-1/2" Sash Opening)
47"	4" x 24"	475	790
58"	4" x 24"	600	1020
70"	4" x 24"	750	1300
94"	4" x 36"	1050	1800
120"	(2) 4" x 24"	1400 ⊕	1075 ⊕

⊕ CFM is calculated with both split sashes open at 18".

⊙ CFM is calculated with one side of split sash fully open at 28" high

CFM = Cubic Feet Per Minute

# FUME HOODS – 5SA SERIES: BENCHTOP MOUNT

## ADA

### Constant Volume Bypass - Vertical Sash

- Designed to meet guidelines of the American Disabilities Act (ADA)
- Electrical and optional service fixtures are located within reach of wheelchair-bound operators
- Standard electrical package includes a vapor proof LED light, light switch / 120V receptacle, and one 120V duplex receptacle
- Stainless steel flush sill bottom air-foil
- 30-1/2" high sash opening with a 36" high sight line
- Frameless sash with laminated safety glass and vented finger pull
- Removable interior and exterior panels for access to service valves
- A wire management chase is provided on both sides of the fume hood
- Poly-resin glastic white interior liner
- UL 1805 Listed and meets ASHRAE 110-95 tests as manufactured

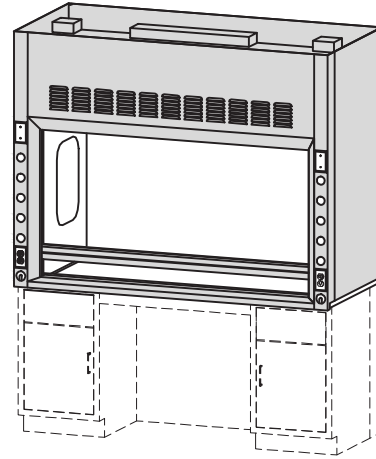

Base Cabinets are optional

#### Product Model Numbers

Width	"A" Depth 31-3/8"	"B" Depth 37-3/8"	"C" Depth 41-3/8"	Height
47"	5SA47A-ADA	5SA47B-ADA	5SA47C-ADA	53"
58"	5SA58A-ADA	5SA58B-ADA	5SA58C-ADA	53"
70"	5SA70A-ADA	5SA70B-ADA	5SA70C-ADA	53"
94"	5SA94A-ADA	5SA94B-ADA	5SA94C-ADA	53"

### Fume Hood Options and Accessories

- Service Fixtures
- Hood Counter Tops and Sink
- Base and Specialty Cabinets
- Monitors / Alarms (not included on -VAV hoods)
- Ceiling Enclosures
- Pre-piping and Pre-wiring
- See Accessories pages for more options

### Sash Style Options

- Combination Sash -CS
- Split Sash -SPS
- Horizontal Sash -HS

### Fume Hood Types

- Variable Air Volume -VAV

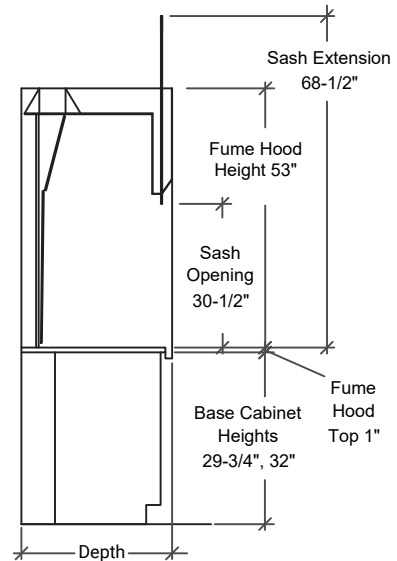

#### 5SA Series CFM Exhaust Volumes .15 S.P.

Fume Hood Width	Exhaust Collar Size	CFM @100 LFM (18" Sash Opening)	CFM @100 LFM (30-1/2" Sash Opening)
47"	4" x 24"	475	790
58"	4" x 24"	600	1020
70"	4" x 24"	750	1300
94"	4" x 36"	1050	1800

CFM = Cubic Feet Per Minute  
LFM = Linear Feet Per Minute



# FUME HOODS – 4SA SERIES: FLOOR-MOUNT



## Dimensional Data

hansonlab.com • 805-498-3121

- Fume hoods are shown with HLS standard construction
- Fume hood standard electrical package is shown with optional factory prewiring to a junction box located on the top of the hood
- A complete selection of options and accessories are located in the HLS fume hood section
- Contact your HLS representative for custom designs or other fume hood information

The dimensions shown are for the following 4SA Series fume hoods:

- Floor-Mount Vertical Sash Fume Hoods
- Floor-Mount Horizontal Sash Fume Hoods

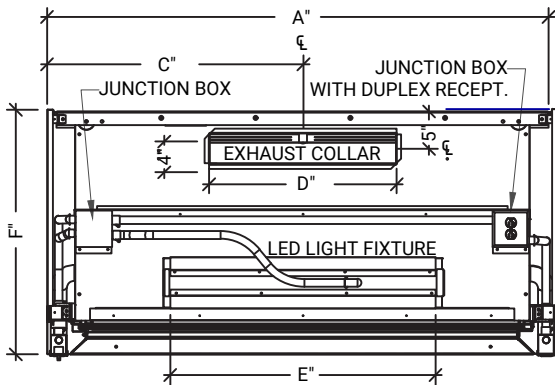

Top View

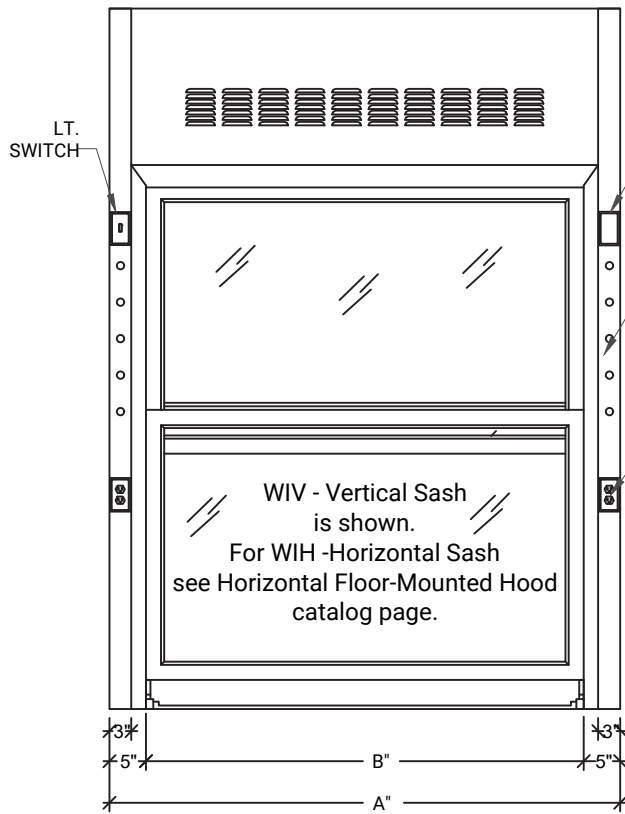

Front View

### 4SA Series Dimensional Chart

Model	A	B	C	D	E
4SA47A	47"	37"	23.5"	24"	24"
4SA58A	58"	48"	29"	24"	24"
4SA70A	70"	60"	35"	24"	24"
4SA94A	94"	84"	47"	36"	24" x 2
4SA120A	120"	110"	*2@31.8"	24" x 2	36" x 2
4SA47B	47"	37"	23.5"	24"	24"
4SA58B	58"	48"	29"	24"	24"
4SA70B	70"	60"	35"	24"	24"
4SA94B	94"	84"	47"	36"	24" x 2
4SA120B	120"	110"	*2@31.8"	24" x 2	36" x 2

\*Center line of collars from either end

Model	F	G	H	I	J
4SA-A	36"	8-3/8"	25-1/2"	24-1/2"	20-1/2"
4SA-B	47-1/2"	19-7/8"	37"	36"	32"

Note: "G" dimensions represent the water service fixture for cup sinks located at the back.

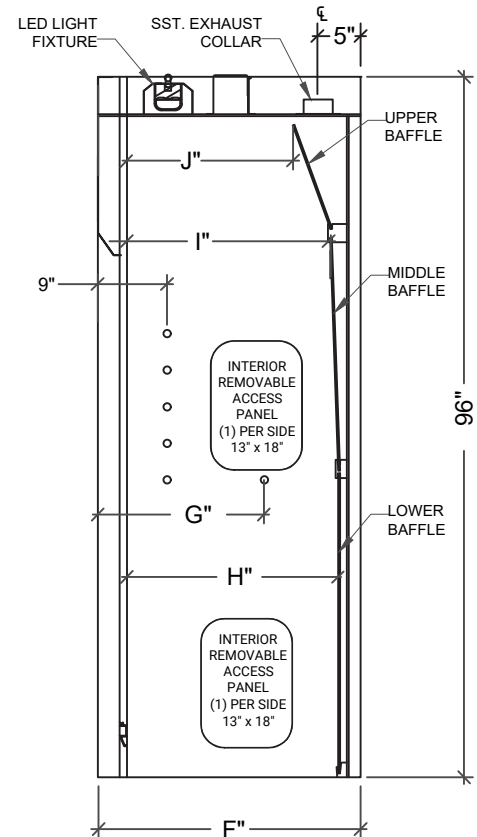

End View

# FUME HOODS – 4SA SERIES: FLOOR-MOUNT

## Vertical Sash

### Constant Volume Bypass - Vertical Sash - WIV

- Designed for large equipment and apparatus
- Standard electrical package includes a vapor-proof LED light, light switch, and two 120V duplex receptacles
- Framed sash with laminated safety glass with vented airfoil design
- Removable interior and exterior panels for access to service valves
- Poly-resin glastic white interior liner
- Floor-Mount fume hoods are shipped knocked down for assembly at job site
- UL 1805 Listed and meets ASHRAE 110-95 tests as manufactured

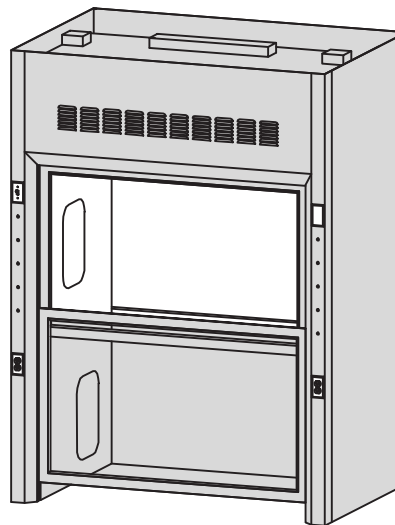

#### Product Model Numbers

Width	"A" Depth 36" O.D.	"B" Depth 47-1/2" O.D.	Height
47"	4SA47AWIV	4SA47BWIV	96"
58"	4SA58AWIV	4SA58BWIV	96"
70"	4SA70AWIV	4SA70BWIV	96"
94"	4SA94AWIV	4SA94BWIV	96"

Note: For floor-mount hoods ordered with a combination sash, the top inner sash has the horizontal sliding panels.

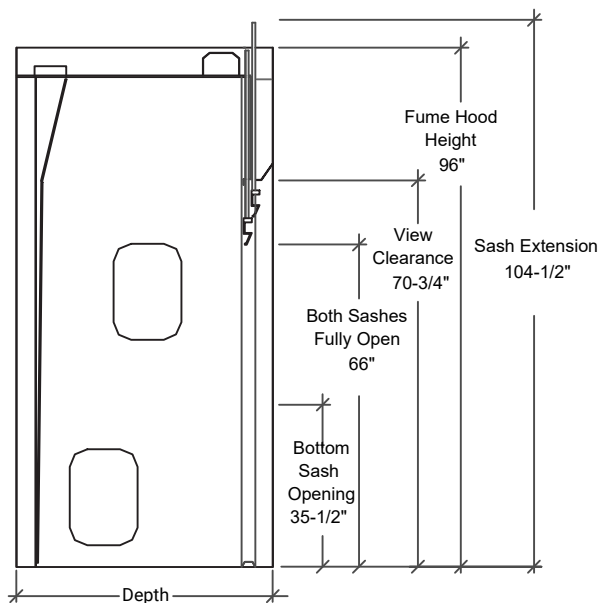

### Fume Hood Options and Accessories

- Service Fixtures
- Epoxy Floor
- Panel-mount sink
- Monitors / Alarms (not included on -VAV hoods)
- Ceiling Enclosures
- Pre-piping and Pre-wiring
- See Accessories pages for more options

### Sash Style Options

- Combination Sash -CS

### Fume Hood Types

- Variable Air Volume -VAV

#### 4SA-WIV Series CFM Exhaust Volumes .15 S.P.

Fume Hood Width	Exhaust Collar Size	CFM @100 LFM (18" Sash Opening)	CFM @100 LFM (One Sash Fully Open - 35-3/4")
47"	4" x 24"	475	975
58"	4" x 24"	600	1250
70"	4" x 24"	750	1600
94"	4" x 36"	1050	2200

CFM = Cubic Feet Per Minute  
LFM = Linear Feet Per Minute

# FUME HOODS – 4SA SERIES: FLOOR-MOUNT



Horizontal Sash

hansonlab.com • 805-498-3121

## Constant Volume Bypass - Horizontal Sash - WIH

- Designed for large equipment and apparatus
- Standard electrical package includes a vapor-proof LED light, light switch, and two 120V duplex receptacles
- Framed sash with laminated safety glass
- Removable interior and exterior panels for access to service valves
- 47", 58", and 70" hoods have two sliding doors
- 94" and 120" hoods have four sliding doors
- 144" hoods have six sliding doors
- Poly-resin glastic white interior liner
- Floor-Mount fume hoods are shipped knocked down for assembly at job site
- UL 1805 Listed and meets ASHRAE 110-95 tests as manufactured

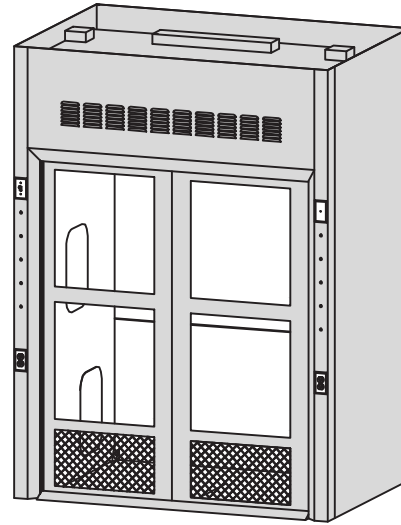

### Product Model Numbers

Width	"A" Depth 36" O.D	"B" Depth 47-1/2" O.D.	Height	Number of Doors
47"	4SA47AWIH	4SA47BWIH	96"	2
58"	4SA58AWIH	4SA58BWIH	96"	2
70"	4SA70AWIH	4SA70BWIH	96"	2
94"	4SA94AWIH	4SA94BWIH	96"	4
120"	4SA120AWIH	4SA120BWIH	96"	4
144"	4SA144AWIH	4SA144BWIH	96"	6

Note: (2) Two sliding door tracks are provided on all sizes of horizontal sash floor-mount fume hoods.

### Fume Hood Options and Accessories

- Service Fixtures
- Epoxy Floor
- Panel-mount sink
- Monitors / Alarms (not included on -VAV hoods)
- Ceiling Enclosures
- Pre-piping and Pre-wiring
- See Accessories pages for more options

### Fume Hood Types

- Variable Air Volume -VAV

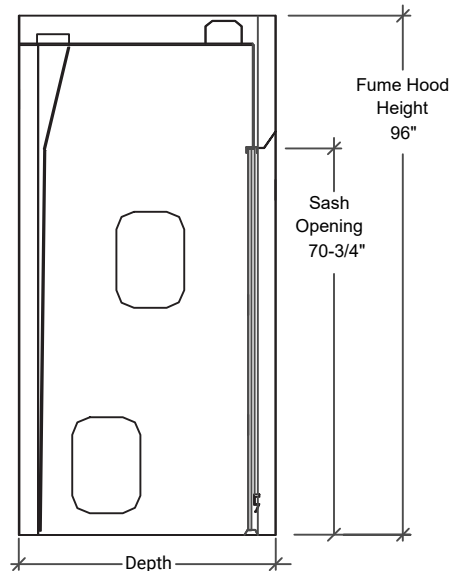

### 4SA-WIH Series CFM Exhaust Volumes .15 S.P.

Fume Hood Width	Exhaust Collar Size	CFM @100 LFM (18" Sash Opening)	CFM @100 LFM (Full Sash Opening)
47"	4" x 24"	1025	1100
58"	4" x 24"	1075	1400
70"	4" x 24"	1125	1750
94"	4" x 36"	1350	2475
120"	(2) 4" x 24"	1500	3225
144"	(2) 4" x 36"	1650	3950

CFM = Cubic Feet Per Minute  
LFM = Linear Feet Per Minute

# FUME HOODS

## Options & Accessories – Base Cabinets

### Fume Hood Cabinet Options

- Base (sink) cabinets are used to support benchtop fume hoods
- Cabinet styles include fume hood cabinets, acid and flammable storage cabinets, and vacuum pump cabinets
- For the complete line of cabinets for fume hoods, see the specialty cabinet section in the base cabinet section of this catalog, starting on page 32.

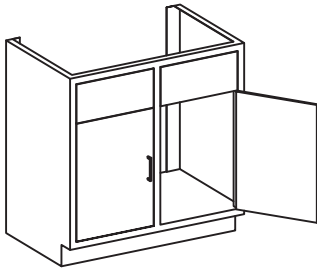
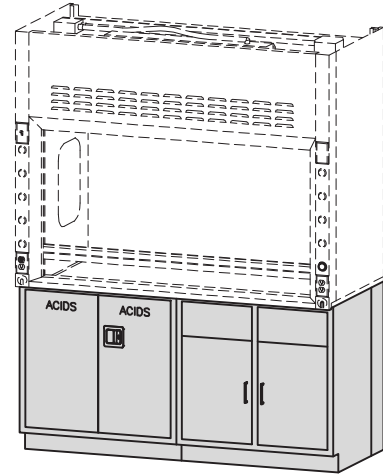

### Base Cabinets

(see sink cabinets on pages 18 and 24)

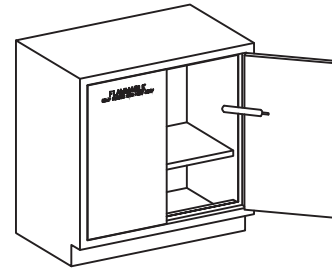

### Flammable Cabinets

(see pages 33, 35, 37)

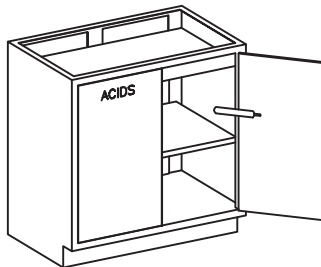

### Acid / Base / Corrosive Storage Cabinets

(see pages 32, 34, 36)

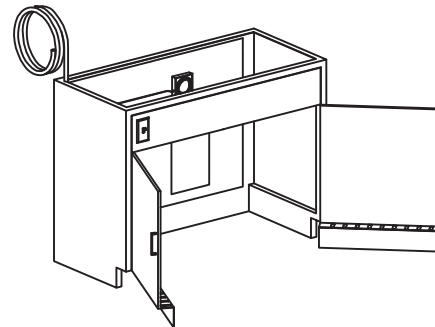

### Vacuum Pump Cabinets

(see pages 39-41)

### Fume Hood Service Fixtures

- Remote control needle valve with black nylon handle with color coded index button and color coded serrated tip
- Services will be mounted on the fume hood, without internal piping
- Optional pre-piping of service fittings are available (see pre-piping section)

Remote Water Valve	
Model	Type
CT3185W-5	Cold Water

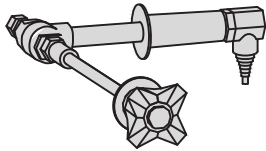

### Service Fitting Color Code:

Air.....	Orange
Cold Water.....	Dark Green
Distilled Water.....	White
Gas.....	Dark Blue
Hot Water.....	Red
Argon.....	Violet
Nitrogen.....	Brown
Oxygen.....	Light Green
Special Gases.....	Light Blue
Steam.....	Black
Vacuum.....	Yellow

### Remote Valves for Air, Gases or Vacuum

Model	Type
CT3185N-LR-AIR	Air
CT3185N-LR-VAC	Vacuum
CT3185N-LR-GAS	Gas
CT3185N-LR-NIT	Nitrogen
CT3185N-LR-AR	Argon

Other specialty gases are available. Contact your HLS representative for more information.

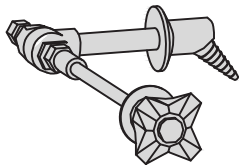

Remote Water Valve With Gooseneck	
Model	Type
CT3185W-9RSVB	Cold Water

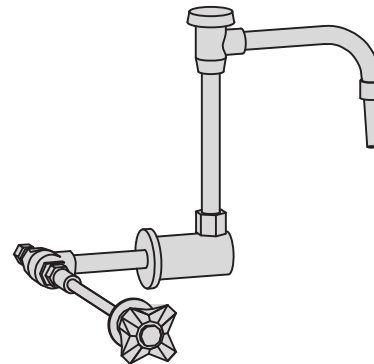

### DI Water-panel or Deck Mounted

- Plastic-Lined or Tin-Lined Brass non-remote type
- Left side handles available
- Cannot be factory pre-piped

Model	Type
L7854	Right hand-Panel Mount
L7853	Right hand-Deck Mount

Other Configurations are available. Contact your HLS representative for more information.

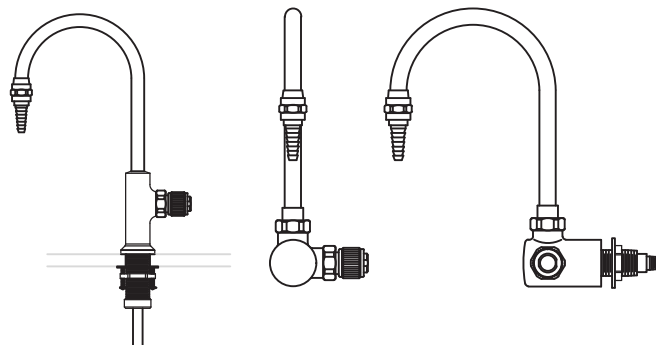

# FUME HOODS

## Options & Accessories – Countertops

### Fume Hood Countertops

- Fume hood tops are 1" thick molded epoxy resin with a 1/4" integrally molded containment area designed to ease cleanups from chemical spills inside the fume hood
- Color: Black Onyx
- Service slots are provided on each side of the fume hood top

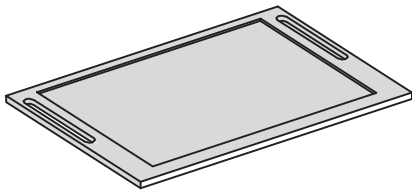

Model	Width	Depth
EHT47A	47"	30"
EHT47B	47"	36"
EHT47C	47"	40"
EHT58A	58"	30"
EHT58B	58"	36"
EHT58C	58"	40"
EHT70A	70"	30"
EHT70B	70"	36"
EHT70C	70"	40"
EHT94A	94"	30"
EHT94B	94"	36"
EHT94C	94"	40"
EHT120A	120"	30"
EHT120B	120"	36"
EHT120C	120"	40"

### Fume Hood Countertops w/ Cup Sink Cutout

- Fume hood tops are 1" thick molded epoxy resin with a 1/4" integrally molded containment area designed to ease cleanups from chemical spills inside the fume hood
- Color: Black Onyx
- Service slots are provided on each side of the fume hood top
- Option for cup sink cutout on right, left or both sides of the countertop
- -CRR for cup sink cutout in right rear of the countertop
- -CLR for cup sink cutout in the left rear of the countertop
- -CBR for cup sink cutouts in the left and right rear of countertop

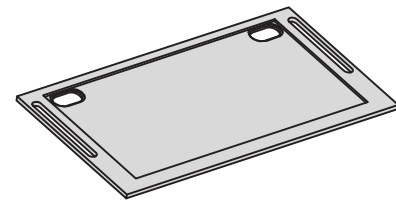

Model	Width	Depth
EHT47A-CBF	47"	30"
EHT47A-CBR	47"	30"
EHT47A-CLR	47"	30"
EHT47A-CRR	47"	30"
EHT47B-CBF	47"	36"
EHT47B-CBR	47"	36"
EHT47B-CLR	47"	36"
EHT47B-CRR	47"	36"
EHT47C-CBF	47"	40"
EHT47C-CBR	47"	40"
EHT47C-CLR	47"	40"
EHT47C-CRR	47"	40"
EHT58A-CBF	58"	30"
EHT58A-CBR	58"	30"
EHT58A-CLR	58"	30"
EHT58A-CRR	58"	30"
EHT58B-CBF	58"	36"
EHT58B-CBR	58"	36"
EHT58B-CLR	58"	36"
EHT58B-CRR	58"	36"

Model	Width	Depth
EHT58C-CBF	58"	40"
EHT58C-CBR	58"	40"
EHT58C-CLR	58"	40"
EHT58C-CRR	58"	40"
EHT70A-CBF	70"	30"
EHT70A-CBR	70"	30"
EHT70A-CLR	70"	30"
EHT70A-CRR	70"	30"
EHT70B-CBF	70"	36"
EHT70B-CBR	70"	36"
EHT70B-CLR	70"	36"
EHT70B-CRR	70"	36"
EHT70C-CBF	70"	40"
EHT70C-CBR	70"	40"
EHT70C-CLR	70"	40"
EHT70C-CRR	70"	40"
EHT94A-CBF	94"	30"
EHT94A-CBR	94"	30"
EHT94A-CLR	94"	30"
EHT94A-CRR	94"	30"

Model	Width	Depth
EHT94B-CBF	94"	36"
EHT94B-CBR	94"	36"
EHT94B-CLR	94"	36"
EHT94B-CRR	94"	36"
EHT94C-CBF	94"	40"
EHT94C-CBR	94"	40"
EHT94C-CLR	94"	40"
EHT94C-CRR	94"	40"
EHT120A-CBF	120"	30"
EHT120A-CBR	120"	30"
EHT120A-CLR	120"	30"
EHT120A-CRR	120"	36"
EHT120B-CBF	120"	36"
EHT120B-CBR	120"	36"
EHT120B-CLR	120"	36"
EHT120B-CRR	120"	36"
EHT120C-CBF	120"	40"
EHT120C-CBR	120"	40"
EHT120C-CLR	120"	40"
EHT120C-CRR	120"	40"

### Fume Hood Electrical Options

- All HLS fume hoods have a standard electrical package, which includes two 115V duplex receptacles, LED strip light, and light switch
- Below are other electrical options available

#### GFI Duplex Receptacles

Model	Type
E113	120V Ground fault protected duplex outlets

Adds one GFI to the existing electrical package

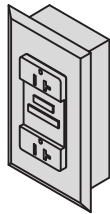

#### Blower Switch

Model	Type
EMBS	A separate toggle switch to operate the blower / fan, 120V 20A

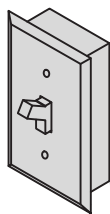

#### Duplex Receptacles

Model	Type
E2300	120V Single duplex receptacle

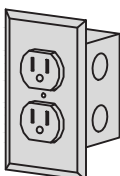

### Fume Hood Cup Sinks

- Cup sinks are used as a drain inside the hood
- Made of black polypropylene, cup sinks install in the fume hood countertop or side panel of floor-mounted fume hoods
- Multiple cup sinks and locations can be specified

#### Panel Mounted

Model	Size
W39027-150	3" x 6" Oval



#### Counter Mounted

Model	Size
CS4R	3" x 6" Oval



#### Explosion-Resistant Light

Model	Type
HAL-48-2L	Explosion-resistant fluorescent light is mounted inside of the hood

Cannot be factory prewired

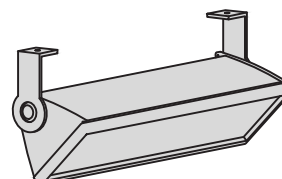

# FUME HOODS

## Options & Accessories – Flow Monitors, Lattice Rod Assemblies

### Air Flow Monitor / Alarm

- Continuously monitors airflow velocity using internal sensors measuring fume hood pressure
- Visual and audible alarm sounds when hood sash height is in an unsafe mode
- Airflow monitors are factory installed
- Contact your HLS representative for full specifications on models available

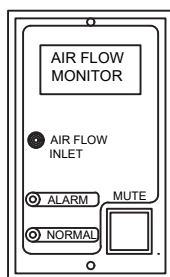

**Model E153B**

LED lights signal both alarm and normal operating modes

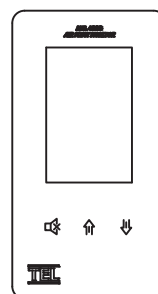

**Model E216**

Maintains constant digital display of fume hood face velocities - configurable visual and audible alarms

### Fume Hood Lattice Rod Assemblies

- Solid 1/2" aluminum rod assemblies consisting of horizontal and vertical rods, adjustable clamps, and mounting flanges used to support apparatus inside the fume hood
- Parts are shipped loose for assembly and installation at the job site

Model	Style	F.H. Size
AAP47	Benchtop	47"
AAP58	Benchtop	58"
AAP70	Benchtop	70"
AAP94	Benchtop	94"
AAP120	Benchtop	120"
AAP47WI	Floor-Mounted	47"
AAP58WI	Floor-Mounted	58"
AAP70WI	Floor-Mounted	70"
AAP94WI	Floor-Mounted	94"
AAP120WI	Floor-Mounted	120"
AAP144WI	Floor-Mounted	144"

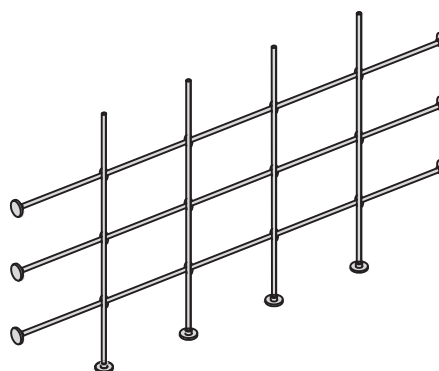



### Fume Hood Ceiling Enclosures

- Provides a finished appearance and encloses the space from the top of the fume hood to the ceiling
- A removable front panel is provided for access
- Enclosure heights can be field trimmed as required
- Finished to match the fume hood

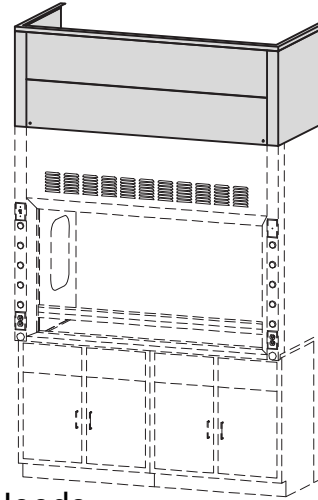

### Ceiling Enclosures 5SA Benchtop Fume Hoods

Note: A verified ceiling height is required for manufacturing the correct height of enclosure

Model	Width	Depth	Height	Model	Width	Depth	Height	Model	Width	Depth	Height
CE47A-18	47"	31-3/8"	18.25"	CE58A-18	58"	31-3/8"	18.25"	CE70A-18	70"	31-3/8"	18.25"
CE47A-22	47"	31-3/8"	22.00"	CE58A-22	58"	31-3/8"	22.00"	CE70A-22	70"	31-3/8"	22.00"
CE47A-24	47"	31-3/8"	24.25"	CE58A-24	58"	31-3/8"	24.25"	CE70A-24	70"	31-3/8"	24.25"
CE47A-28	47"	31-3/8"	28.00"	CE58A-28	58"	31-3/8"	28.00"	CE70A-28	70"	31-3/8"	28.00"
CE47A-30	47"	31-3/8"	30.25"	CE58A-30	58"	31-3/8"	30.25"	CE70A-30	70"	31-3/8"	30.25"
CE47A-34	47"	31-3/8"	34.00"	CE58A-34	58"	31-3/8"	34.00"	CE70A-34	70"	31-3/8"	34.00"
CE47A-36	47"	31-3/8"	36.25"	CE58A-36	58"	31-3/8"	36.25"	CE70A-36	70"	31-3/8"	36.25"
CE47A-42	47"	31-3/8"	42.25"	CE58A-42	58"	31-3/8"	42.25"	CE70A-42	70"	31-3/8"	42.25"
CE47A-46	47"	31-3/8"	46.00"	CE58A-46	58"	31-3/8"	46.00"	CE70A-46	70"	31-3/8"	46.00"
CE47A-48	47"	31-3/8"	48.25"	CE58A-48	58"	31-3/8"	48.25"	CE70A-48	70"	31-3/8"	48.25"
CE47B-18	47"	37-3/8"	18.25"	CE58B-18	58"	37-3/8"	18.25"	CE70B-18	70"	37-3/8"	18.25"
CE47B-22	47"	37-3/8"	22.00"	CE58B-22	58"	37-3/8"	22.00"	CE70B-22	70"	37-3/8"	22.00"
CE47B-24	47"	37-3/8"	24.25"	CE58B-24	58"	37-3/8"	24.25"	CE70B-24	70"	37-3/8"	24.25"
CE47B-28	47"	37-3/8"	28.00"	CE58B-28	58"	37-3/8"	28.00"	CE70B-28	70"	37-3/8"	28.00"
CE47B-30	47"	37-3/8"	30.25"	CE58B-30	58"	37-3/8"	30.25"	CE70B-30	70"	37-3/8"	30.25"
CE47B-34	47"	37-3/8"	34.00"	CE58B-34	58"	37-3/8"	34.00"	CE70B-34	70"	37-3/8"	34.00"
CE47B-36	47"	37-3/8"	36.25"	CE58B-36	58"	37-3/8"	36.25"	CE70B-36	70"	37-3/8"	36.25"
CE47B-42	47"	37-3/8"	42.25"	CE58B-42	58"	37-3/8"	42.25"	CE70B-42	70"	37-3/8"	42.25"
CE47B-46	47"	37-3/8"	46.00"	CE58B-46	58"	37-3/8"	46.00"	CE70B-46	70"	37-3/8"	46.00"
CE47B-48	47"	37-3/8"	48.25"	CE58B-48	58"	37-3/8"	48.25"	CE70B-48	70"	37-3/8"	48.25"
CE47C-18	47"	41-3/8"	18.25"	CE58C-18	58"	41-3/8"	18.25"	CE70C-18	70"	41-3/8"	18.25"
CE47C-22	47"	41-3/8"	22.00"	CE58C-22	58"	41-3/8"	22.00"	CE70C-22	70"	41-3/8"	22.00"
CE47C-24	47"	41-3/8"	24.25"	CE58C-24	58"	41-3/8"	24.25"	CE70C-24	70"	41-3/8"	24.25"
CE47C-28	47"	41-3/8"	28.00"	CE58C-28	58"	41-3/8"	28.00"	CE70C-28	70"	41-3/8"	28.00"
CE47C-30	47"	41-3/8"	30.25"	CE58C-30	58"	41-3/8"	30.25"	CE70C-30	70"	41-3/8"	30.25"
CE47C-34	47"	41-3/8"	34.00"	CE58C-34	58"	41-3/8"	34.00"	CE70C-34	70"	41-3/8"	34.00"
CE47C-36	47"	41-3/8"	36.25"	CE58C-36	58"	41-3/8"	36.25"	CE70C-36	70"	41-3/8"	36.25"
CE47C-42	47"	41-3/8"	42.25"	CE58C-42	58"	41-3/8"	42.25"	CE70C-42	70"	41-3/8"	42.25"
CE47C-46	47"	41-3/8"	46.00"	CE58C-46	58"	41-3/8"	46.00"	CE70C-46	70"	41-3/8"	46.00"
CE47C-48	47"	41-3/8"	48.25"	CE58C-48	58"	41-3/8"	48.25"	CE70C-48	70"	41-3/8"	48.25"

# FUME HOODS

## Options & Accessories – Ceiling Enclosures

### Fume Hood Ceiling Enclosures (cont'd)

- Provides a finished appearance and encloses the space from the top of the fume hood to the ceiling
- A removable front panel is provided for access
- Enclosure heights can be field trimmed as required
- Finished to match the fume hood

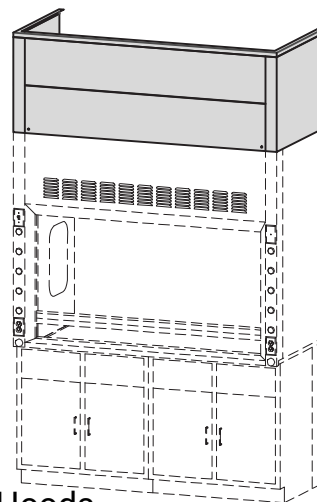

### Ceiling Enclosures 5SA Benchtop Fume Hoods

Note: A verified ceiling height is required for manufacturing the correct height of enclosure

Model	Width	Depth	Height	Model	Width	Depth	Height
CE94A-18	94"	31-3/8"	18.25"	CE120A-18	120"	31-3/8"	18.25"
CE94A-22	94"	31-3/8"	22.00"	CE120A-22	120"	31-3/8"	22.00"
CE94A-24	94"	31-3/8"	24.25"	CE120A-24	120"	31-3/8"	24.25"
CE94A-28	94"	31-3/8"	28.00"	CE120A-28	120"	31-3/8"	28.00"
CE94A-30	94"	31-3/8"	30.25"	CE120A-30	120"	31-3/8"	30.25"
CE94A-34	94"	31-3/8"	34.00"	CE120A-34	120"	31-3/8"	34.00"
CE94A-36	94"	31-3/8"	36.25"	CE120A-36	120"	31-3/8"	36.25"
CE94A-42	94"	31-3/8"	42.25"	CE120A-42	120"	31-3/8"	42.25"
CE94A-46	94"	31-3/8"	46.00"	CE120A-46	120"	31-3/8"	46.00"
CE94A-48	94"	31-3/8"	48.25"	CE120A-48	120"	31-3/8"	48.25"
CE94B-18	94"	37-3/8"	18.25"	CE120B-18	120"	37-3/8"	18.25"
CE94B-22	94"	37-3/8"	22.00"	CE120B-22	120"	37-3/8"	22.00"
CE94B-24	94"	37-3/8"	24.25"	CE120B-24	120"	37-3/8"	24.25"
CE94B-28	94"	37-3/8"	28.00"	CE120B-28	120"	37-3/8"	28.00"
CE94B-30	94"	37-3/8"	30.25"	CE120B-30	120"	37-3/8"	30.25"
CE94B-34	94"	37-3/8"	34.00"	CE120B-34	120"	37-3/8"	34.00"
CE94B-36	94"	37-3/8"	36.25"	CE120B-36	120"	37-3/8"	36.25"
CE94B-42	94"	37-3/8"	42.25"	CE120B-42	120"	37-3/8"	42.25"
CE94B-46	94"	37-3/8"	46.00"	CE120B-46	120"	37-3/8"	46.00"
CE94B-48	94"	37-3/8"	48.25"	CE120B-48	120"	37-3/8"	48.25"
CE94C-18	94"	41-3/8"	18.25"	CE120C-18	120"	41-3/8"	18.25"
CE94C-22	94"	41-3/8"	22.00"	CE120C-22	120"	41-3/8"	22.00"
CE94C-24	94"	41-3/8"	24.25"	CE120C-24	120"	41-3/8"	24.25"
CE94C-28	94"	41-3/8"	28.00"	CE120C-28	120"	41-3/8"	28.00"
CE94C-30	94"	41-3/8"	30.25"	CE120C-30	120"	41-3/8"	30.25"
CE94C-34	94"	41-3/8"	34.00"	CE120C-34	120"	41-3/8"	34.00"
CE94C-36	94"	41-3/8"	36.25"	CE120C-36	120"	41-3/8"	36.25"
CE94C-42	94"	41-3/8"	42.25"	CE120C-42	120"	41-3/8"	42.25"
CE94C-46	94"	41-3/8"	46.00"	CE120C-46	120"	41-3/8"	46.00"
CE94C-48	94"	41-3/8"	48.25"	CE120C-48	120"	41-3/8"	48.25"

### Floor-Mounted Fume Hood Ceiling Enclosures

- Provides a finished appearance and encloses the space from the top of the fume hood to the ceiling
- A removable front panel is provided for access
- Enclosure heights can be field trimmed as required
- Finished to match the fume hood

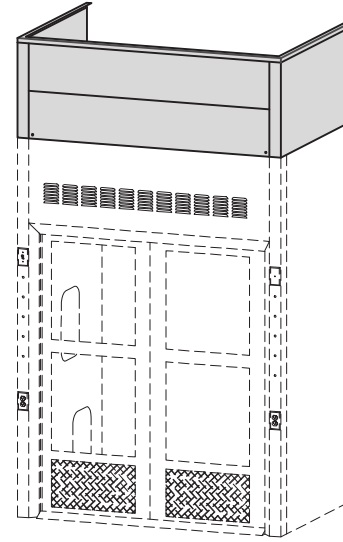

Model	Width	Depth	Height
CEWI47A-12	47"	36"	12.00"
CEWI47A-18	47"	36"	18.00"
CEWI47A-24	47"	36"	24.00"
CEWI47A-36	47"	36"	36.00"
CEWI47B-12	47"	47-1/2"	12.00"
CEWI47B-18	47"	47-1/2"	18.00"
CEWI47B-24	47"	47-1/2"	24.00"
CEWI47B-36	47"	47-1/2"	36.00"
CEWI58A-12	58"	36"	12.00"
CEWI58A-18	58"	36"	18.00"
CEWI58A-24	58"	36"	24.00"
CEWI58A-36	58"	36"	36.00"
CEWI58B-12	58"	47-1/2"	12.00"
CEWI58B-18	58"	47-1/2"	18.00"
CEWI58B-24	58"	47-1/2"	24.00"
CEWI58B-36	58"	47-1/2"	36.00"
CEWI70A-12	70"	36"	12.00"
CEWI70A-18	70"	36"	18.00"
CEWI70A-24	70"	36"	24.00"
CEWI70A-36	70"	36"	36.00"
CEWI70B-12	70"	47-1/2"	12.00"
CEWI70B-18	70"	47-1/2"	18.00"
CEWI70B-24	70"	47-1/2"	24.00"
CEWI70B-36	70"	47-1/2"	36.00"

Model	Width	Depth	Height
CEWI94A-12	94"	36"	12.00"
CEWI94A-18	94"	36"	18.00"
CEWI94A-24	94"	36"	24.00"
CEWI94A-36	94"	36"	36.00"
CEWI94B-12	94"	47-1/2"	12.00"
CEWI94B-18	94"	47-1/2"	18.00"
CEWI94B-24	94"	47-1/2"	24.00"
CEWI94B-36	94"	47-1/2"	36.00"
CEWI120A-12	120"	36"	12.00"
CEWI120A-18	120"	36"	18.00"
CEWI120A-24	120"	36"	24.00"
CEWI120A-36	120"	36"	36.00"
CEWI120B-12	120"	47-1/2"	12.00"
CEWI120B-18	120"	47-1/2"	18.00"
CEWI120B-24	120"	47-1/2"	24.00"
CEWI120B-36	120"	47-1/2"	36.00"
CEWI144A-12	144"	36"	12.00"
CEWI144A-18	144"	36"	18.00"
CEWI144A-24	144"	36"	24.00"
CEWI144A-36	144"	36"	36.00"
CEWI144B-12	144"	47-1/2"	12.00"
CEWI144B-18	144"	47-1/2"	18.00"
CEWI144B-24	144"	47-1/2"	24.00"
CEWI144B-36	144"	47-1/2"	36.00"

# FUME HOODS

## Options & Accessories – Extractor Arms

### Fume Extractor Arms

- A localized fume extractor with articulated joints lets you position the exhaust where you need it
- Available in wall, ceiling, or bench top mounting bracket options
- Extractors must be connected to a building exhaust system
- For more information on sizes and styles, contact your HLS representative

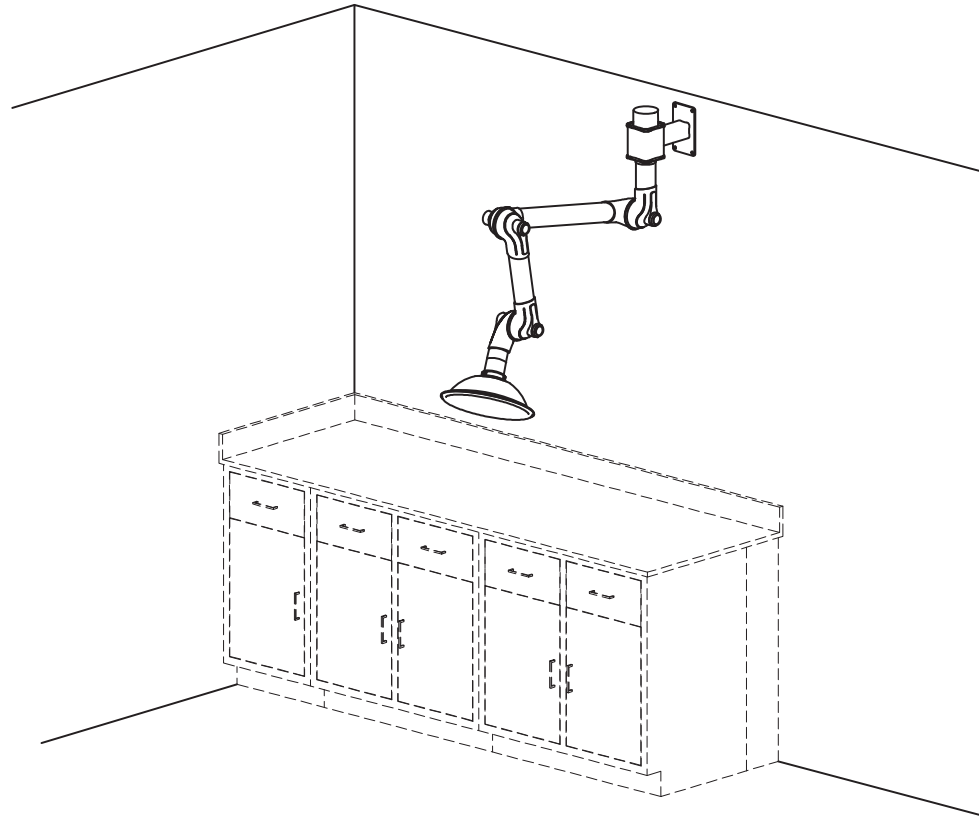

### Island Mounted Canopy Hoods

- Canopy hoods are designed to exhaust heat, steam, or odors when mounted over laboratory benches above equipment
- Manufactured from 18 ga. cold rolled steel with the same chemical resistant finish as the HLS casework or with stainless steel construction
- Connecting ductwork is not included
- Threaded rods are included for installation to the ceiling structure
- For stainless steel construction, add -SS at the end of the model number

Island Mounted Canopy Hoods

Model	Width	Depth	Height	Style
CHI3624-12	36"	24"	12"	Island
CHI3624-18	36"	24"	18"	Island
CHI3624-24	36"	24"	24"	Island
CHI3630-12	36"	30"	12"	Island
CHI3630-18	36"	30"	18"	Island
CHI3630-24	36"	30"	24"	Island
CHI3636-12	36"	36"	12"	Island
CHI3636-18	36"	36"	18"	Island
CHI3636-24	36"	36"	24"	Island
CHI4824-12	48"	24"	12"	Island
CHI4824-18	48"	24"	18"	Island
CHI4824-24	48"	24"	24"	Island
CHI4830-12	48"	30"	12"	Island
CHI4830-18	48"	30"	18"	Island
CHI4830-24	48"	30"	24"	Island
CHI4836-12	48"	36"	12"	Island
CHI4836-18	48"	36"	18"	Island
CHI4836-24	48"	36"	24"	Island
CHI5824-12	58"	24"	12"	Island
CHI5824-18	58"	24"	18"	Island
CHI5824-24	58"	24"	24"	Island
CHI5830-12	58"	30"	12"	Island
CHI5830-18	58"	30"	18"	Island
CHI5830-24	58"	30"	24"	Island
CHI5836-12	58"	36"	12"	Island
CHI5836-18	58"	36"	18"	Island
CHI5836-24	58"	36"	24"	Island
CHI7224-12	72"	24"	12"	Island
CHI7224-18	72"	24"	18"	Island
CHI7224-24	72"	24"	24"	Island
CHI7230-12	72"	30"	12"	Island
CHI7230-18	72"	30"	18"	Island
CHI7230-24	72"	30"	24"	Island
CHI7236-12	72"	36"	12"	Island
CHI7236-18	72"	36"	18"	Island
CHI7236-24	72"	36"	24"	Island

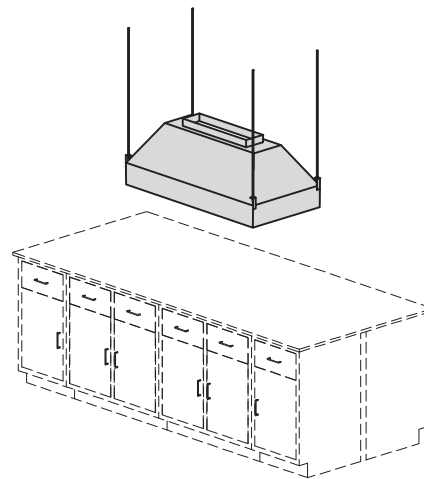

# FUME HOODS

## Options & Accessories – Canopy Hoods

### Wall Mounted Canopy Hoods

- Canopy hoods are designed to exhaust heat, steam, or odors when mounted over laboratory benches above equipment
- Manufactured from 18 ga. cold rolled steel with the same chemical resistant finish as the HLS casework or with stainless steel construction
- Connecting ductwork is not included
- Threaded rods are included for installation to the ceiling structure
- For stainless steel construction, add -SS at the end of the model number

Wall Mounted Canopy Hoods

Model	Width	Depth	Height	Style
CHW3624-12	36"	24"	12"	Wall
CHW3624-18	36"	24"	18"	Wall
CHW3624-24	36"	24"	24"	Wall
CHW3630-12	36"	30"	12"	Wall
CHW3630-18	36"	30"	18"	Wall
CHW3630-24	36"	30"	24"	Wall
CHW3636-12	36"	36"	12"	Wall
CHW3636-18	36"	36"	18"	Wall
CHW3636-24	36"	36"	24"	Wall
CHW4824-12	48"	24"	12"	Wall
CHW4824-18	48"	24"	18"	Wall
CHW4824-24	48"	24"	24"	Wall
CHW4830-12	48"	30"	12"	Wall
CHW4830-18	48"	30"	18"	Wall
CHW4830-24	48"	30"	24"	Wall
CHW4836-12	48"	36"	12"	Wall
CHW4836-18	48"	36"	18"	Wall
CHW4836-24	48"	36"	24"	Wall
CHW5824-12	58"	24"	12"	Wall
CHW5824-18	58"	24"	18"	Wall
CHW5824-24	58"	24"	24"	Wall
CHW5830-12	58"	30"	12"	Wall
CHW5830-18	58"	30"	18"	Wall
CHW5830-24	58"	30"	24"	Wall
CHW5836-12	58"	36"	12"	Wall
CHW5836-18	58"	36"	18"	Wall
CHW5836-24	58"	36"	24"	Wall
CHW7224-12	72"	24"	12"	Wall
CHW7224-18	72"	24"	18"	Wall
CHW7224-24	72"	24"	24"	Wall
CHW7230-12	72"	30"	12"	Wall
CHW7230-18	72"	30"	18"	Wall
CHW7230-24	72"	30"	24"	Wall
CHW7236-12	72"	36"	12"	Wall
CHW7236-18	72"	36"	18"	Wall
CHW7236-24	72"	36"	24"	Wall

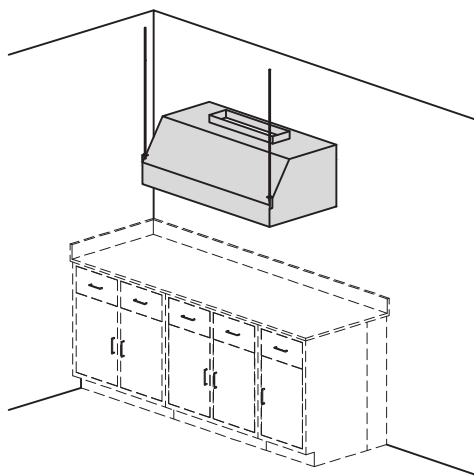

## Need it now? Get it now!

Hundreds of Hanson Express products are in stock and ready to ship in as little as 72 hours.

## You'll get all the other value that Hanson brings to your project too.

The ability to add casework from the full Hanson catalog with our shorter standard lead times.

The options to mix and match with other HLS lines, including Fixed, Mobile, or our Agility line of laboratory design solutions.

## In stock & out the door

### Hanson Express Index

Page

*In stock and ready to ship in as little as 24 hours.*

<b>STEEL CASEWORK</b> .....	152
• Base Cabinets .....	152
• Wall, Sink and Tall Cabinets .....	153
• Mobile Cabinets .....	154
• Casework Accessories, Standing Height .....	155
• Casework Accessories, Sitting Height .....	156
<b>TABLES AND WORKSTATIONS</b> .....	157
• M-Series Workstations & Countertops .....	158
• Utility Tables .....	159
• Utility Table Accessories .....	160
<b>LABORATORY FIXTURES AND ACCESSORIES</b> .....	162
• Faucets, Eyewashes .....	162
• Pegboards, Sinks .....	163
<b>SHELVING</b> .....	164
• Benchtop-mounted Systems; Wall Standards .....	164
• Individual Shelves and Brackets .....	165
<b>FUME HOODS</b> .....	166
• Fume Hoods, Countertops and Chemical Storage Cabinets .....	166



# HANSON EXPRESS

## Base Cabinets

### Standing Height Cabinets - 35-3/4"

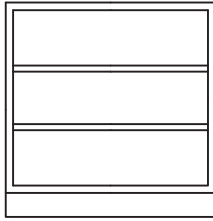

Model	Width
HX-DY35H	35"

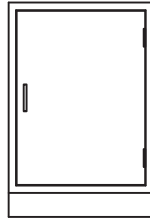

Model	Width
HX-AA24H	24-1/8"



Model	Width
HX-AE18H	18-1/8"
HX-AE24H	24-1/8"

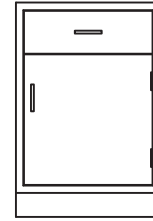

Model	Width
HX-AB18H	18-1/8"
HX-AB24H	24-1/8"

### Standing Height Cabinets - 35-3/4"

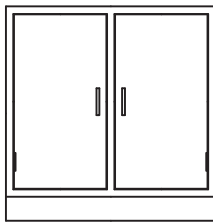

Model	Width
HX-DA35H	35"
HX-DA47H	47"

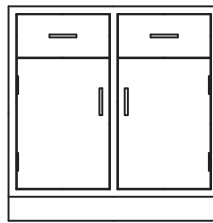

Model	Width
HX-DD35H	35"
HX-DD47H	47"

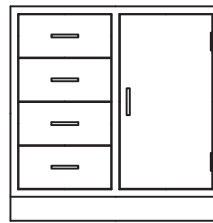

Model	Width
HX-DG35H	35"

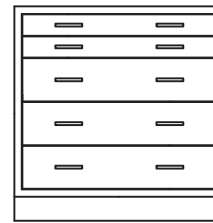

Model	Width
HX-DN47H	47"



Model	Width
HX-DZ47H	47"

### Sitting Height Cabinets - 29-3/4"

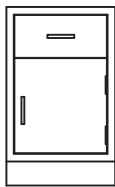

Model	Width
HX-AB18L	18-1/8"

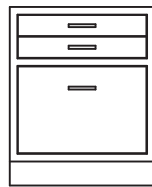

Model	Width
HX-AG24L	24-1/8"

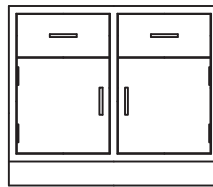

Model	Width
HX-DD35L	35"

### Corner Base Cabinets - 35-3/4"

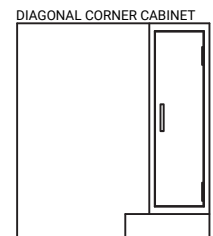
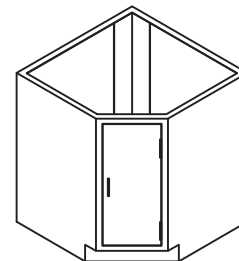

Model	Width
DX14H	32"

DX diagonal corner cabinets do not have shelves



### Wall Cabinets

Framed Glass  
Hinged Doors

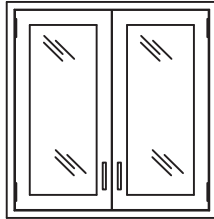

Model	Width	Height	Depth
HX-E35M	35"	36"	13"
HX-E47M	47"	36"	13"

### Wall Cabinets

Solid Metal  
Hinged Doors

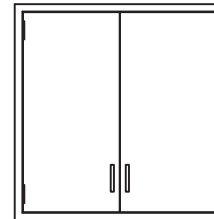

Model	Width	Height	Depth
HX-B35M	35"	36"	13"
HX-B47M	47"	36"	13"

### Sink Cabinets

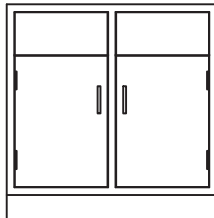

Model	Width
HX-DB35H	35"
HX-DB47H	47"
HX-DB58H	58"
HX-DB35ADA (32" HEIGHT)	35"

### Tall Storage Cabinets

Framed Glass  
Hinged Doors

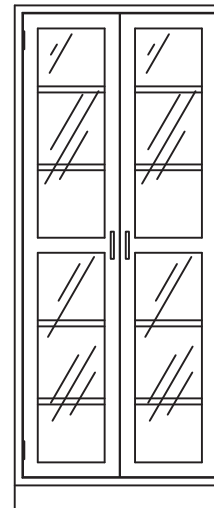

Model	Width	Height	Depth
HX-L47HA	47"	84"	18"

# HANSON EXPRESS

## Mobile Cabinets

### Standard Height - 32 1/2"

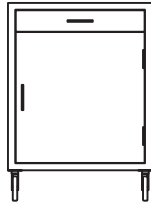

Model	Width
HX-AB18HM	18-1/8"



Model	Width
HX-CP24HM	24"

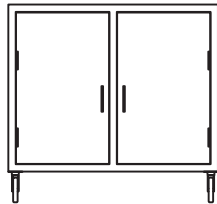

Model	Width
HX-DA30HM	30"

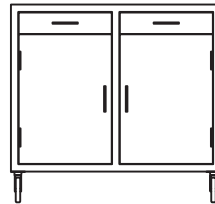

Model	Width
HX-DD30HM	30"

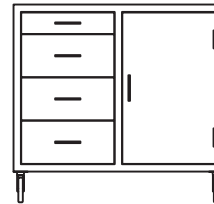

Model	Width
HX-DG30HM	30"

### Low Height - 25-1/4"



Model	Width
HX-AF18LM	18-1/8"

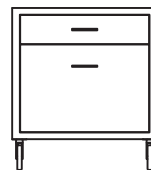

Model	Width
HX-AG18LM	18-1/8"

### Standing Height Cabinets - 35-3/4"

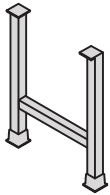

#### Table leg, dual flanged

Model	Size
HX-FHL36A	35-3/4"H x 22"D

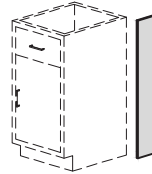

#### End Filler Panels

- Includes one single filler angle

Model	Size
HX-PSF1H	1"W x 35-3/4"H
HX-PSF7H	7"W x 35-3/4"H
HX-PSF13H	13"W x 35-3/4"H

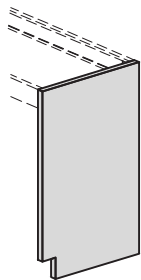

#### End Support Panel

- Used in place of legs on one end of apron rails or drawer frames
- 1-1/4" wide
- Leg levelers and three support angles provided

Model	Height	Depth
HX-HGL36A	35-3/4"	22"

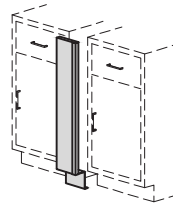

#### Front Filler Panels

- Includes one double-slip filler angle

Model	Size
HX-BF1H	1"W x 35-3/4"H
HX-BF6H	6"W x 35-3/4"H
HX-BF12H	12"W x 35-3/4"H
HX-BF18H	18"W x 35-3/4"H

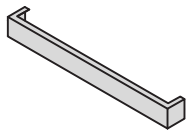

#### Apron Rail

Model	Width
HX-A30	30"W x 3-1/2"H
HX-A35	35"W x 3 1/2"H
HX-A47	47"W x 3 1/2"H

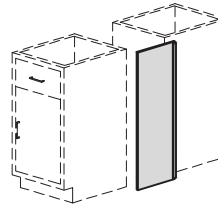

#### Island Filler Panels

Model	Size
HX-BCF3H	3"W x 35"H
HX-BCF8H	8"W x 35"H
HX-BCF14H	14"W x 35"H

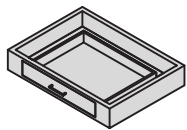

#### Drawer Housing, 1 Drawer

Model	Size
HX-DH-1-30A	30"W x 3-1/2"H x 22"D
HX-DH-1-35A	35"W x 3-1/2"H x 22"D
HX-DH-1-42A	47"W x 3-1/2"H x 22"D

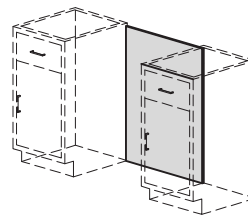

#### Knee Space Filler Panels

- Includes two single filler angles

Model	Size
HX-KSP3035	30"W x 35"H
HX-KSP3535	35"W x 35"H
HX-KSP4735	47"W x 35"H

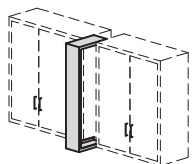

#### Wall Cabinet Filler Panel

Model	Size
HX-WCF6M13	6"W x 36"H

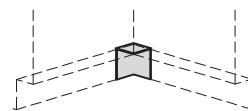

#### Island Filler Panels

Model	Size
HX-TSF	3"W x 4"H

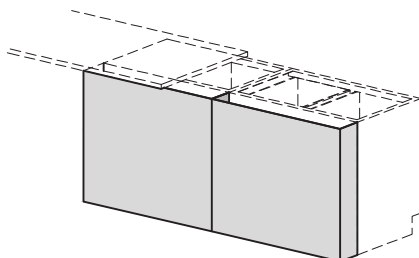

#### Standing Height 35-3/4" x 6" Deep

Model	Width	Depth	Height
HX-REP24H6	24-1/8"	6"	35-3/4"
HX-REP35H6	35"	6"	35-3/4"
HX-REP47H6	47"	6"	35-3/4"

### Sitting Height Cabinets - 29-3/4"

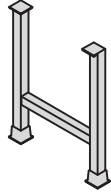

#### Table leg, dual flanged

Model	Size
HX-FHL30A	29-3/4"H x 22"D

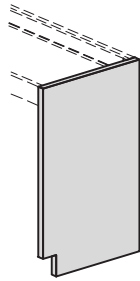

#### End Support Panel

- Used in place of legs on one end of apron rails or drawer frames
- 1-1/4" wide
- Leg levelers and three support angles provided

Model	Height	Depth
HX-HGL30A	29-3/4"	22"

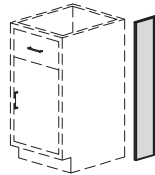

#### End Filler Panels

- Includes one single filler angle

Model	Size
HX-PSF7L	7"W x 29"H

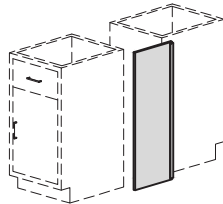

#### Island Filler Panels

Model	Size
HX-BCF14L	14"W x 29"H

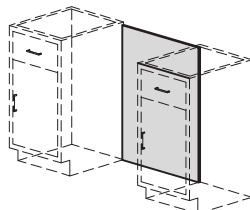

#### Knee Space Filler Panels

- Includes two single filler angles

Model	Size
HX-KSP3029	30"W x 29"H
HX-KSP3529	35"W x 29"H
HX-KSP4729	47"W x 29"H

### M-Series Bench Systems

This new line of benches has been engineered with basic features to meet your load and usage demands, including knock-down design for economical transportation

Pre-configured M1 and M2 versions are available in-stock through Hanson Express in four (4) styles:

- M1 or M2 without power or accessories
- M1 or M2 with four (4) white 20A 120V duplexes, single circuit, cord exit at top of post, and L5-20P plug Power, data, and gas service options can be upgraded or re-configured in the field with minimal effort

Note: If Quick-Ship is not a requirement, fully optioned M-Series benches per your specification can also be supplied through the HLS sales team with standard HLS lead times

### Hanson Express Bench Configurations:

- M1 - Single-sided, 60" or 72" wide x 30" deep, 2x3" upright post
- M2 - Double-sided, 60" or 72" wide x 60" deep, 2x3" upright post

### Included features

- Six-position adjustable work top height (1" increments from 30-3/4 to 36-3/4")
- Knockdown design (assembly required)
- 14-gauge steel tube construction typical
- Durable powdercoat finish
- 84" tall upright posts
- Accessory port covers allow future upgrades as needed
- Static load capacity, equally distributed combined system: 1200 lbs (SEFA category 4)

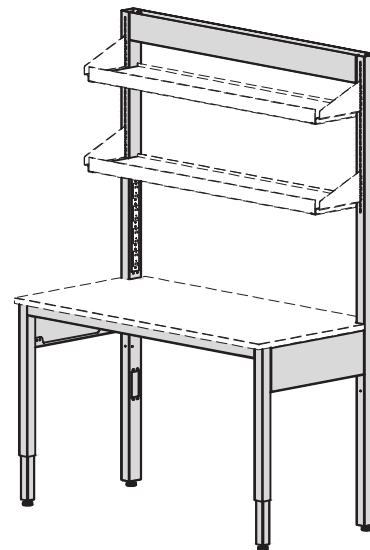

M1 - (shown w/ accessories)

### Available options:

- Pre-wired 20A 120V duplexes in left-hand vertical post. (see pre-configured benches on next page)
- 1" thick lab-grade phenolic work surface
- Upper shelving
- Mobile and suspended cabinets
- Horizontal power strip
- Bin box mount

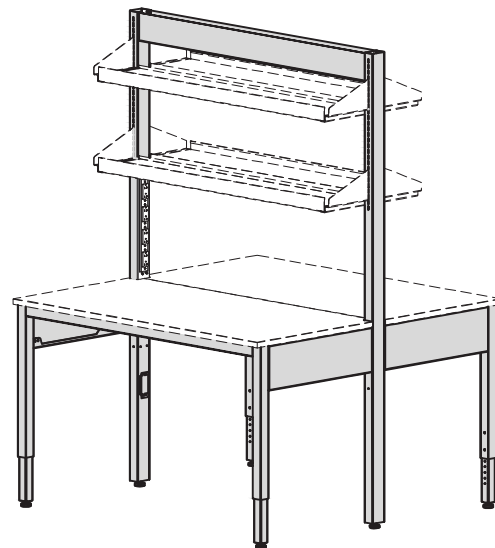

M2- (shown w/ accessories)

# HANSON EXPRESS

## M-Series Workstations & Countertops

### Basic pre-configured bench assemblies

Part Number	Description	Frame Width	Frame Depth	Top Size (sold separately)	Frame configuration
<b>HX-M1-6030H</b>	SINGLE FRAME ASY, M1, 60W x 30D x 84H, NO ACCYS, NO TOP	59-3/4"	28"	60" x 30"	Single-side
<b>HX-M1-6030H-1P</b>	SINGLE FRAME ASY, M1, 60W x 30W x 84H, LH POST 4-DUPLEX POWER W/CORD, NO TOP	59-3/4"	28"	60" x 30"	Single-side
<b>HX-M2-6060H</b>	DOUBLE FRAME ASY, M2, 60W x 60D x 84H, NO ACCYS, NO TOP	59-3/4"	58"	60" x 60" (2 piece top)	Double-side
<b>HX-M2-6060H-1P</b>	DOUBLE FRAME ASY, M2, 60W x 60D x 84H, 1-POST 4-DUPLEX POWER W/CORD, NO TOP	59-3/4"	58"	60" x 60" (2 piece top)	Double-side
<b>HX-M1-7230H</b>	SINGLE FRAME ASY, M1, 72W x 30D x 84H, NO ACCYS, NO TOP	71-3/4"	28"	72" x 30"	Single-side
<b>HX-M1-7230H-1P</b>	SINGLE FRAME ASY, M1, 72W x 30D x 84H, LH POST 4-DUPLEX POWER W/CORD, NO TOP	71-3/4"	28"	72" X 30"	Single-side
<b>HX-M2-7260H</b>	DOUBLE FRAME ASY, M2, 72W x 60D x 84H, NO ACCYS, NO TOP	71-3/4"	58"	72" x 60" (2 piece top)	Double-side
<b>HX-M2-7260H-1P</b>	DOUBLE FRAME ASY, M2, 72W X 60D X 84H, 1-POST 4-DUPLEX POWER W/CORD, NO TOP	71-3/4"	58"	72" x 60" (2 piece top)	Double-side

### Work surfaces; M-Series workstations (Science-grade black phenolic, 1" thick)

Part Number	Description
HX-CTOP-PHENM16030-1.0IN	COUNTERTOP, PHENOLIC, M1 60x30 BLACK, FIN EDGES, 1" THK, EACH
HX-CTOP-PHENM17230-1.0IN	COUNTERTOP, PHENOLIC, M1 72x30 BLACK, FIN EDGES, 1" THK, EACH
HX-CTOP-PHENM260DS-1.0IN	COUNTERTOP, PHENOLIC, M2 60x30 DS BLACK, FIN EDGES, 1" THK, EA (2 REQ'D)
HX-CTOP-PHENM272DS-1.0IN	COUNTERTOP, PHENOLIC, M2 72x30 DS BLACK, FIN EDGES, 1" THK, EA (2 REQ'D)

### Standard Duty Adjustable & Fixed Height Table Frames

- Tables can be used with upright posts, upper shelves, lower shelf, power strip kit, single drawer or mobile cabinet
- Countertop, brackets, shelves, and cabinets must be ordered separately
- Typical countertop overhang on Utility Table frame is 1/8" at sides, 1" at front, flush at rear (for optional upright kit installation)
- Assembly required

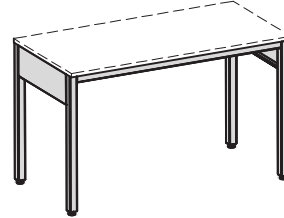
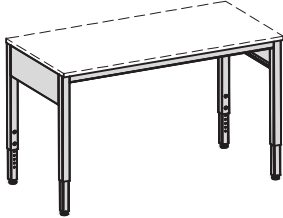

### Adjustable Height Table Frames

Frame height adjustment is from 29-3/4" - 35-3/4" w/out countertop

Model	Frame Width	Frame Depth	Top Size
HX-UTA36B	35-3/4"	29"	36" x 30"
HX-UTA48B	47-3/4"	29"	48" x 30"
HX-UTA60B	59-3/4"	29"	60" x 30"
HX-UTA72B	71-3/4"	29"	72" x 30"

### Fixed Height Table Frames

35-3/4" High w/out countertop

Model	Frame Width	Frame Depth	Top Size
HX-UTFH36B	35-3/4"	29"	36" x 30"
HX-UTFH48B	47-3/4"	29"	48" x 30"
HX-UTFH60B	59-3/4"	29"	60" x 30"
HX-UTFH72B	71-3/4"	29"	72" x 30"

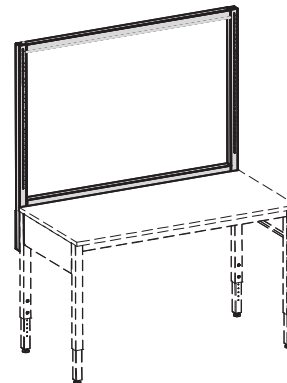
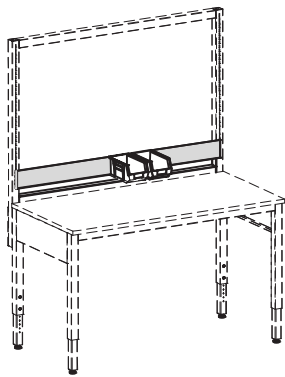

### Bin Box Mounts

Bin box not included  
(also compatible w/ Agility & HDW systems)

Model	Length
HX-A13412-36	36"
HX-A13412-48	48"
HX-A13412-60	60"
HX-A13112-72	72"

### Upright Post Kits

Includes 2" X 2" vertical posts, horizontal cross members, and hardware.  
Table, shelves, and shelf brackets not included

Model	Frame Width	Frame Height
HX-K13409-36	35-3/4"	52-1/2"
HX-K13409-48	47-3/4"	52-1/2"
HX-K13409-60	59-3/4"	52-1/2"
HX-K13409-72	71-3/4"	52-1/2"

# HANSON EXPRESS

## Utility Table Accessories

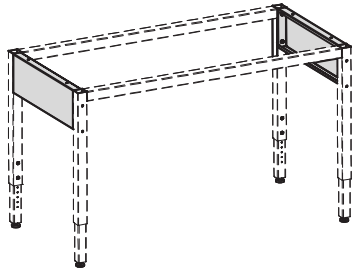

### Frame Depth Extension Apron

Frame depth extension aprons accommodates 24" or 36" deep work surface (sold separately)

Model	Apron Width	Finished Frame Depth
HX-K13408-24	19"	23"
HX-K13408-36	31"	35"

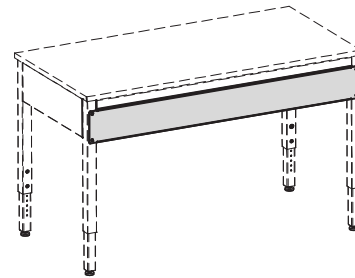

### Rear Pan

Suggested for applications with dynamic equipment

Model	Length	Height
HX-C13406-36	36"	6-1/2"
HX-C13406-48	48"	6-1/2"
HX-C13406-60	60"	6-1/2"
HX-C13406-72	72"	6-1/2"

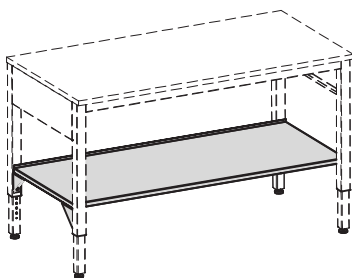

### Lower Shelving Kits

Under counter use includes shelf, & mounting brackets. Table frame, & work surface sold separately.

Model	Length	Depth
HX-K7003-36	35-1/2"	24-3/4"
HX-K7003-48	47-1/2"	24-3/4"
HX-K7003-60	59-3/4"	24-3/4"
HX-K7003-72	71-3/4"	24-3/4"

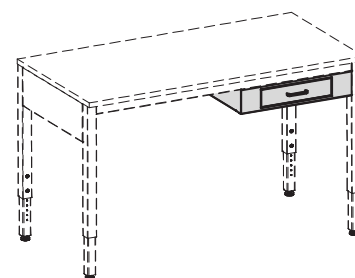

### Single Drawer

Includes single 24" x 28" drawer housing. Table frame and work surface sold separately.

Model	Width	Depth
HX-DH-1-24B	24-1/8"	28"



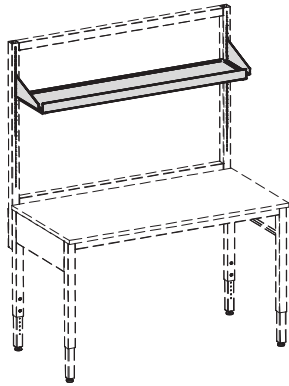

### Upper Shelf Kits

Includes 12" deep painted metal shelf, and brackets. Requires upright post kit, and table sold separately (also compatible w/ Agility & HDW systems)

Model	Width	Depth
HX-K13070-12	31-1/2"	12"
HX-K13032-12	43-1/2"	12"
HX-K13033-12	55-1/2"	12"
HX-K13034-12	67-1/2"	12"

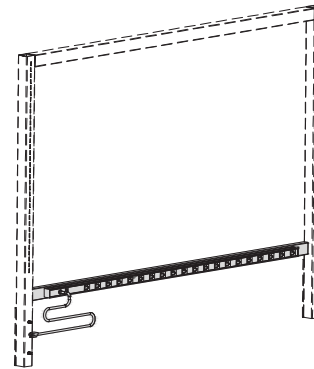

### Power Strip Kits (15A)

Upright post kit sold separately (also compatible w/ Agility & HDW systems)

Model	Mount Width	Strip Length	Cord Length	Outlet Qty.
HX-K13411-36	34.65"	24"	6'	8
HX-K13411-48	46.65"	36"	15'	12
HX-K13411-60	58.65"	48"	15'	8
HX-K13411-72	70.65"	60"	15'	20

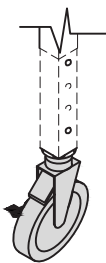

### Table Caster Kit

- Available for all 4-leg tables, set includes 4 swivel locking stem casters
- Caster wheels are 4" dia. non-marking gray thermoplastic rubber tread on a polypropylene core.
- Casters add 5-1/8" to table height unless table height is adjusted prior to caster installation

Model	Quantity
HX-CASTERX4	4

**Note:**

Casters are not to be used to "Level" tables. Caster stems must be screwed tight into the table leg to insure stability.

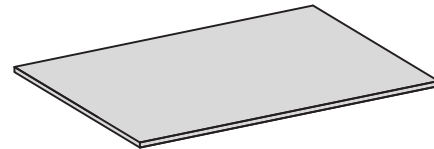

### Phenolic Resin Table Tops - Black

Model	Width	Depth	Thickness
HX-3630CRP	36"	30"	3/4"
HX-4830CRP	48"	30"	3/4"
HX-6030CRP	60"	30"	3/4"
HX-7230CRP	72"	30"	3/4"

# HANSON EXPRESS

## Fixtures & Accessories - Faucets & Eyewashes

### Single Faucet - Counter Mount

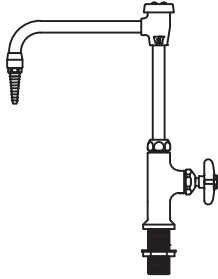

HX-L614-8VB

Counter mounted cold water vacuum breaker gooseneck faucet. Chrome plated brass with 8" spread rigid / swing gooseneck. Removable straight serrated hose connector.

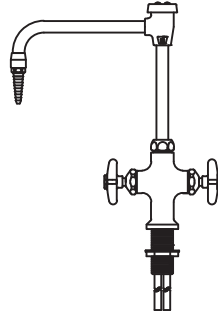

HX-L414-8VB

Counter mounted hot and cold mixing vacuum breaker gooseneck faucet. Chrome plated brass with an 8" spread rigid / swing gooseneck. Removable straight serrated hose connector.

### Distilled Water Faucet

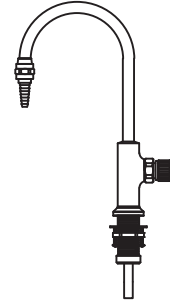

HX-L7853

Chrome plated w/ polypropylene liner. Right hand deck mounted distilled water faucet. Profax natural polypropylene material. Standard 3/8" female NPT inlet connection. Molded serrated outlet fitting connects to different tubing sizes. Full flow at 1 full turn. 6" spread rigid gooseneck.

### Emergency Eyewash

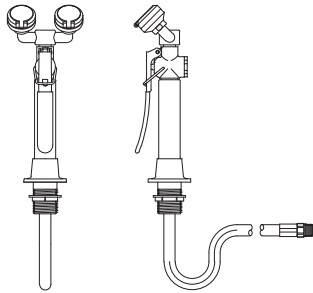

HX-EW1022

Deck mounted dual purpose eye wash / drench hose with two gentle spray outlet heads angled at 45° and squeeze valve with locking clip.

Flange, shank, and locknut for attaching to table top are included. 3/8" I.P.S. male thread swivel inlet.

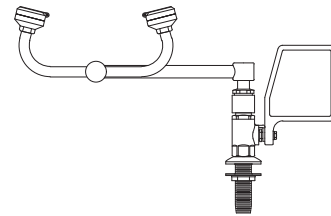

HX-EW806

Right hand sided sink-top mounted eyewash. Spray heads swivel 90 degrees from storage to operational position. Water flow is activated by flag handle. Each spray head has a "flip top" dust cover, internal flow control, and filter to remove impurities from the water flow. Chrome-plated brass stay-open ball valve. 1/2" NPT male inlet. Furnished with locknut and washer for securing to countertop.

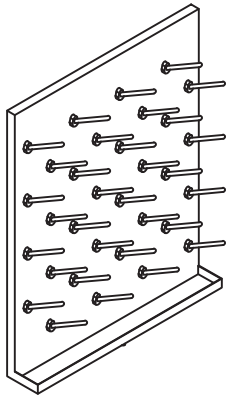

### Stainless Steel Pegboards

Includes integral drip tray with a drainage tube.

Model	Size	Pegs	Drip Tray
HX-V2424-2	24"W x 24"H	32	2"
HX-V2430-2	24"W x 30"H	50	2"



### Drop-In Epoxy Sinks

Model	Inside			Outside			Drain		Outlet
	A	B	C	D	E	F	G	H	
D30-S	18.0	15.0	11.0	19.6	16.6	11.9	3.5	3.5	Corner
D55-S	25.0	15.0	10.0	26.6	16.6	11.0	4.5	4.5	Corner
♿ ADA Compliant Sinks:									
A25-S	18.0	15.0	5.0	19.6	16.6	5.8	3.5	3.5	Corner
A55-S	25.0	15.0	5.1	26.6	16.6	5.4	3.9	3.9	Corner

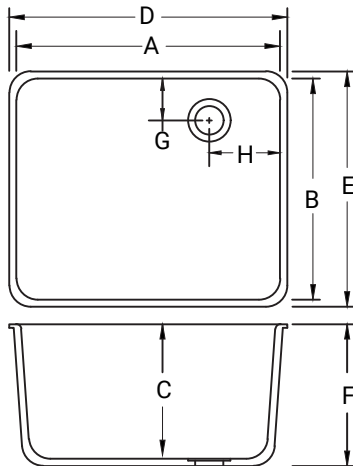

### S504-B

Black Polypropylene sink outlet. Complete with locknut and disc strainer. 1 1/2" BSP male straight thread outlet.

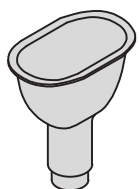
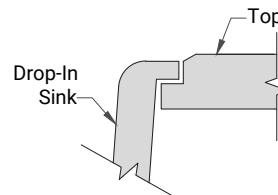
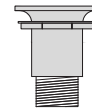

### Cup Sink

Model	Size
HX-CS4R	6" x 3"

Black Polypropylene. Complete with removable strainer. 6" x 3" inside dimension. 1 1/2" I.P.S. male straight thread outlet. (Overall height is 7 1/2")

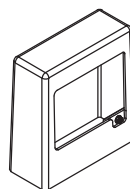

### Double Pedestal Double Sided

Model	Finish
HX-E600SA	Satin (Brushed) Aluminum

# HANSON EXPRESS

## Shelving - Benchtop-mounted; Wall Standards

### Benchtop-Mounted Adjustable Shelving System

- Can be used on new or existing island and peninsula benches
- Components shown are sold individually
- Select matching widths for your application
- 48" high x 2" wide x 3" deep powdercoated steel uprights mount onto the countertop through integrated mounting plate
- Upright posts are located at center and end locations
- End posts must be positioned a minimum of 3-1/4" from end of countertop at each side
- A center cord gap is provided between shelves for vertical integration of shelf equipment
- Shelves are adjustable and removable
- Shelving system is compatible with standard Hanson shelves
- See below for in-stock shelves or see shelving pages 4.04-4.08 for sizes and styles

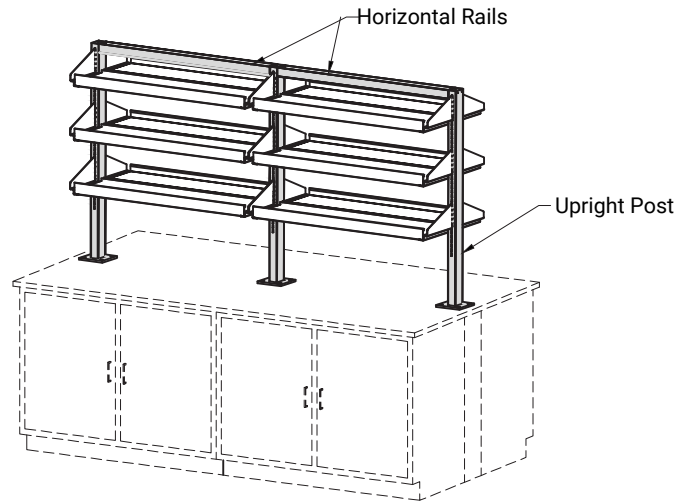

### Upright Post

- Upright Post (each; includes benchtop mounting hardware)

Model	Size	Height
HX-BTUP48-G2	2" W X 3" D	29-3/4"

### Horizontal Top Rails

- Top rails attach between upright posts installed at the center lines listed below

Model	Width	Centerline of Upright Post
HX-C13174-31	31-3/4"	33-3/4"
HX-C13174-43	43-3/4"	45-3/4"
HX-C13174-55	55-3/4"	57-3/4"
HX-C13174-67	67-3/4"	69-3/4"

### Wall Standards

- Wall standards are painted steel, 12 ga., 2" w x 5/8" d, double slotted for use with bookend brackets
- Shelves are adjustable in 1" increments
- In-wall backing required for all wall shelving
- Shelves sold separately

Model	Height
HX-HDS48-G2	48"

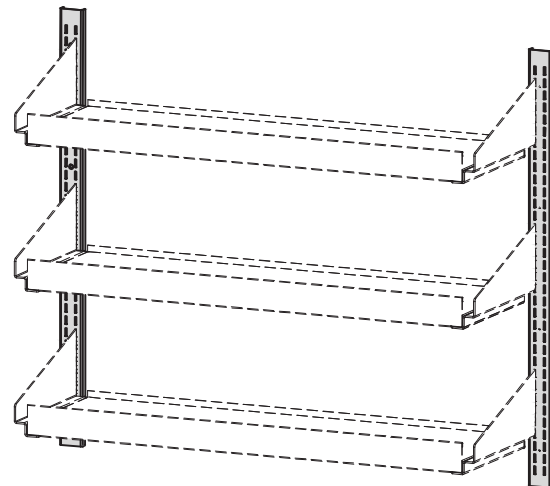
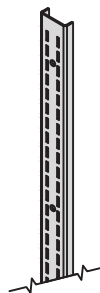

- Includes (1) left and (1) right side bookend bracket per kit

Model	Shelf Width	Depth
HX-K13070-12	33 1/2"	12"
HX-K13032-12	45 1/2"	12"
HX-K13033-12	57 1/2"	12"
HX-K13034-12	69 1/2"	12"

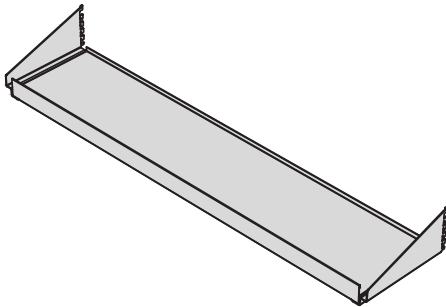

- Single Shelf - does not include brackets

Model	Width	Depth
HX-C13070-12	33 1/2"	12"
HX-C13032-12	45 1/2"	12"
HX-C13033-12	57 1/2"	12"
HX-C13034-12	69 1/2"	12"

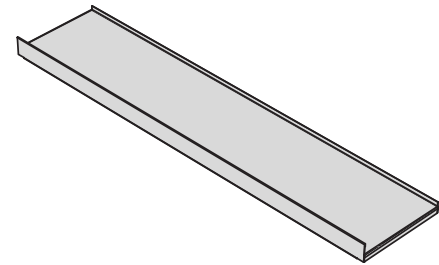

### Bookend Brackets

- Offset style bookend brackets are 6.9" high, 11 ga. painted steel
- Included in Hanson Express shelving kits
- 12" deep brackets

Model	Usage
HX-C13026-1	Left hand side; 12" or 14" D shelves
HX-C13026-2	Right hand side; 12" or 14" D shelves

Each model number includes a set of Left and Right hand brackets

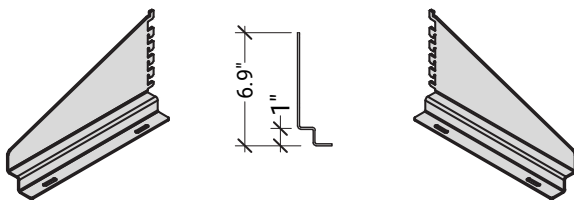

### Inverted Top Brackets

- Positions the top shelf surfaces 5/8" below top of post (see page 111 for "flush mount" upper shelves and brackets)
- Reversed offset style bookend brackets are 4.9" high, 11 ga. painted steel

Model	Shelf Bracket	Used With
HX-C13029-1	12"	Left hand side; 12" D shelves
HX-C13029-2	12"	Right hand side; 12" D shelves

Each model number includes a set of Left and Right hand brackets

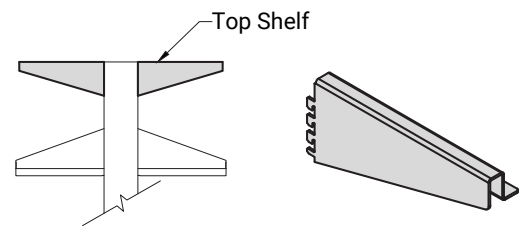

# HANSON EXPRESS

## Fume Hoods, Countertops & Chemical Storage Cabinets

### Constant Volume By-Pass - Vertical Sash

- General purpose 47" or 70" chemical fume hoods
- Standard electrical package includes a vapor proof LED light, light switch, and two 120V duplex receptacles, prewired to a junction box located at the top of the hood
- See page 134 for more details

### Fume Hood Options

- Service Fixtures - Air, Vacuum, Gas, Cold Water
- Hood Counter Tops and Cup Sink
- Base and Specialty Cabinets
- Monitors / Alarms
- Pre-piping of Service Fixtures

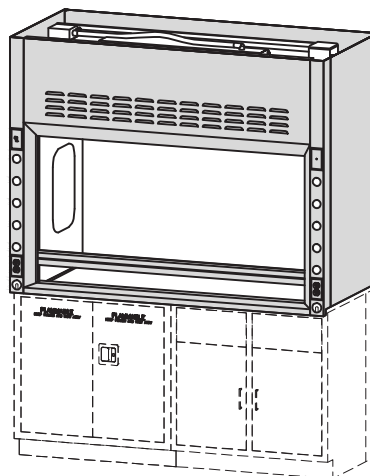

### Acid Cabinets

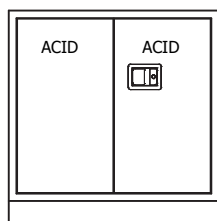
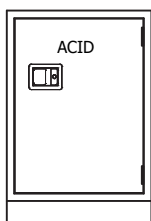

Model	Height
HX-ASB24H	24"

Model	Height
HX-ASB35H	35"
HX-ASB47H	47"

### Flammable Storage Cabinets

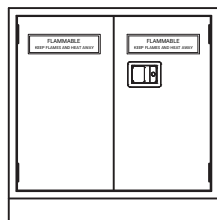
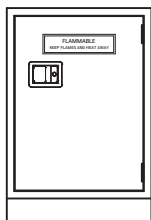

Model	Height
HX-FSB24H	24"

Model	Height
HX-FSB35H	35"
HX-FSB47H	47"

### Vacuum Pump Cabinet

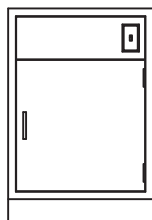

Model	Height
HX-VAC24HF	24"

### Fume Hoods

Model	Height	Depth
HX-5SA47A	48"	31-3/8"
HX-5SA70A	70"	31-3/8"

### Fume Hood Countertops

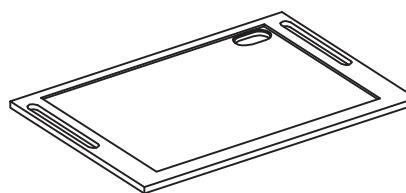

Model	Width
HX-EHT47A	47"
HX-EHT70A	70"
HX-EHT47A-C*	47"
HX-EHT70A-C*	70"

\*w/ cup sink cutout at right rear corner

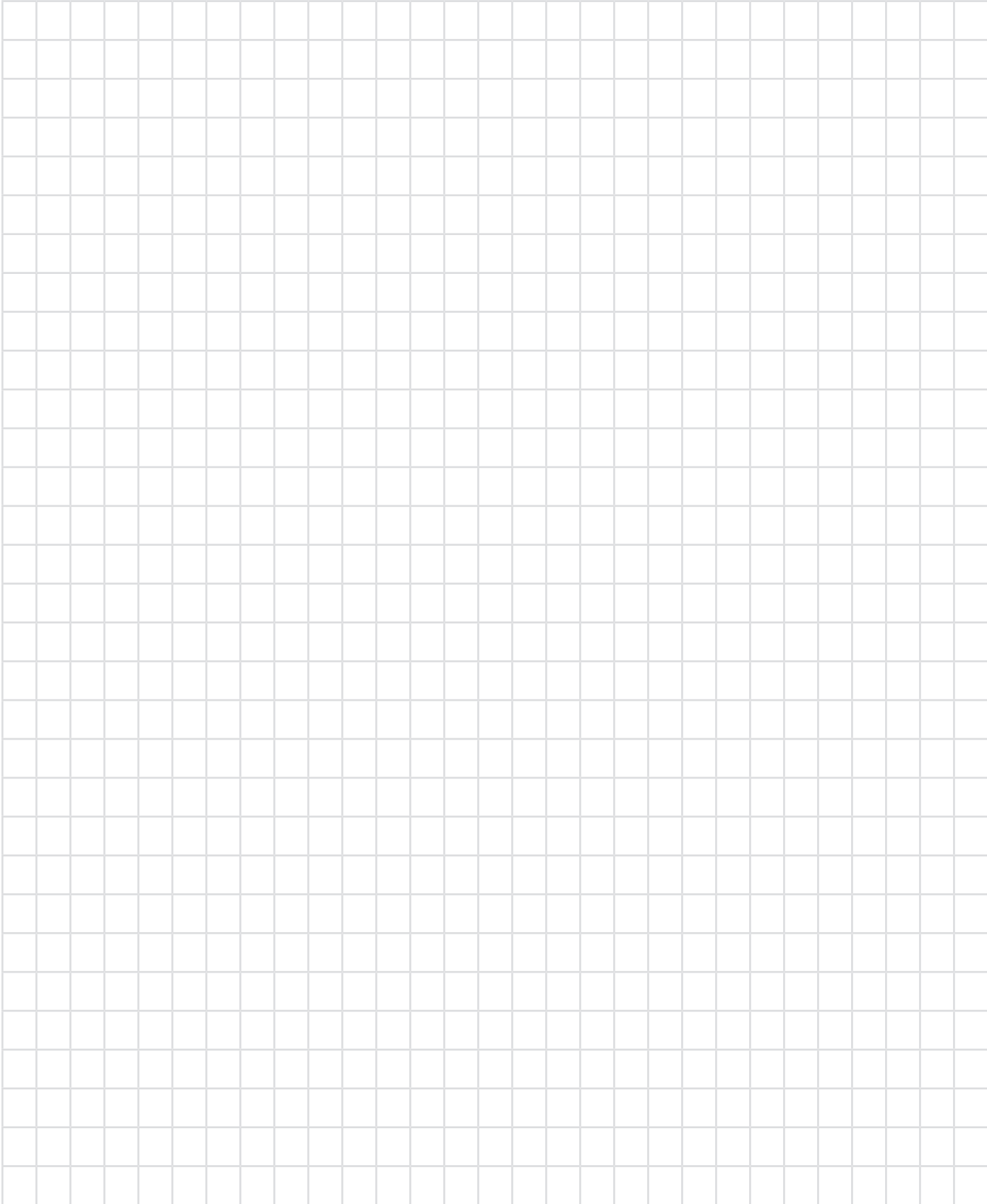

Better Products,  
Delivered Faster,  
Tailored to Your Needs.



**Phone:** 805-498-3121

**Fax:** 805-498-185

**Email:** [info@hansonlab.com](mailto:info@hansonlab.com)

747 Calle Plano  
Camarillo, CA 93012